

Lighting Management Unit with High Voltage Boost Converter

Check for Samples: [LP3958](#)

FEATURES

- High-Efficiency Boost Converter With Programmable Output Voltage
- Two Individual Drivers for Serial Display Backlight LEDs
- Three Drivers for Serial Keypad LEDs
- Automatic Dimming Controller
- Stand Alone Serial Keypad LEDs Controller
- Three General-Purpose IO Pins
- 25-Bump DSBGA Package: 2.54mm x 2.54mm x 0.6mm

APPLICATIONS

- Cellular Phones and PDAs
- MP3 Players
- Digital Cameras

Typical Application

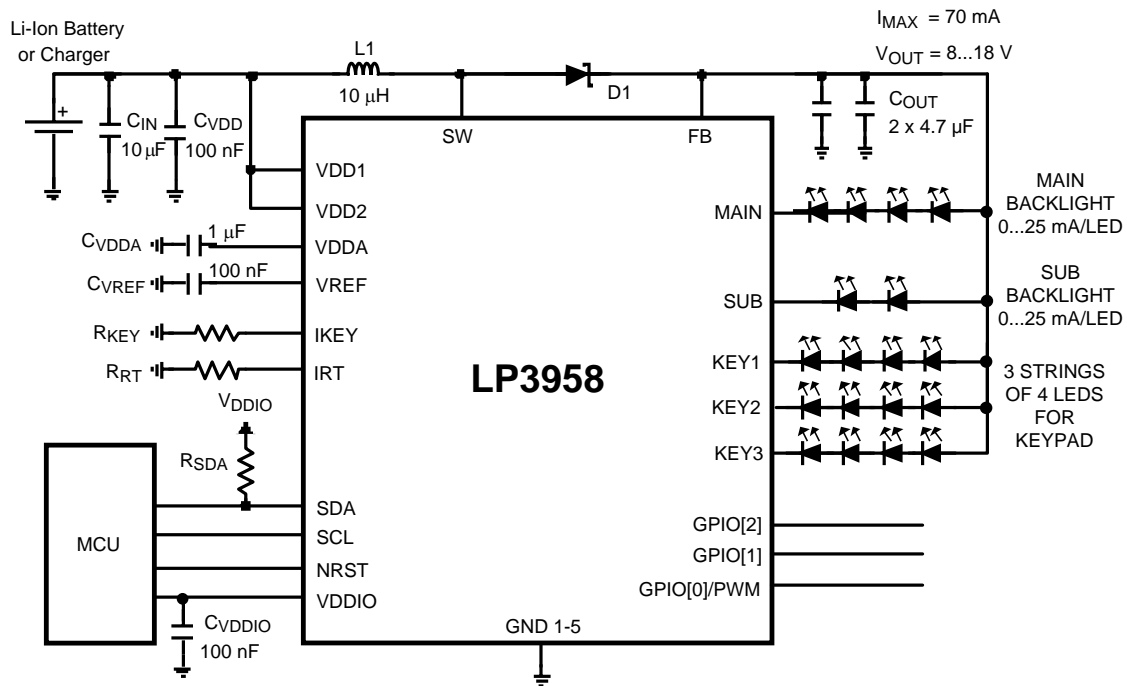

DESCRIPTION

LP3958 is a Lighting Management Unit for portable applications. It is used to drive display backlight and keypad LEDs. The device can drive 5 separately connected strings of LEDs with high voltage boost converter.

The keypad LED driver allows driving LEDs from high voltage boost converter or separate supply voltage. The MAIN and SUB outputs are high resolution current mode drivers. Keypad LED outputs can be used in switch mode and current mode. External PWM control can be used for any selected outputs.

The device is controlled through 2-wire low voltage I²C compatible interface that reduces the number of required connections.

LP3958 is offered in a tiny 25-bump DSBGA package.



Please be aware that an important notice concerning availability, standard warranty, and use in critical applications of Texas Instruments semiconductor products and disclaimers thereto appears at the end of this data sheet.

All trademarks are the property of their respective owners.

CONNECTION DIAGRAMS

25-Bump Thin DSBGA Package, Large Bump, Package Number YZR0025

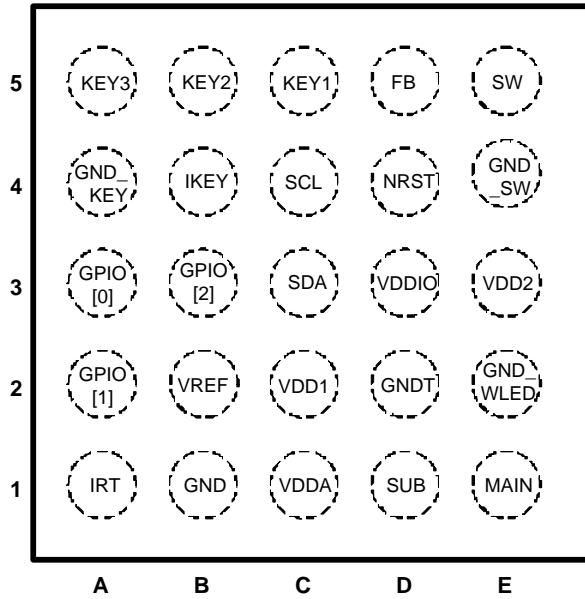

Figure 1. Top View

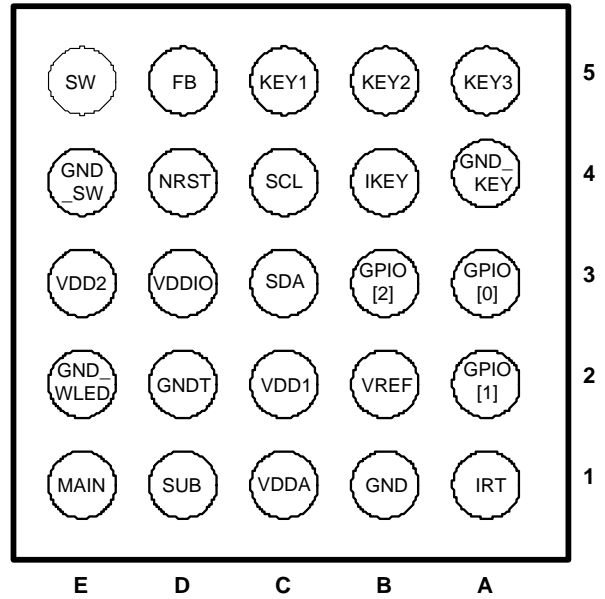

Figure 2. Bottom View

Table 1. PIN DESCRIPTIONS

Pin No.	Name	Type	Description
5E	SW	Output	Boost Converter Power Switch
5D	FB	Input	Boost Converter Feedback
5C	KEY1	Output	Keypad LED Output 1 (Current Sink)
5B	KEY2	Output	Keypad LED Output 2 (Current Sink)
5A	KEY3	Output	Keypad LED Output 3 (Current Sink)
4E	GND_SW	Ground	Power Switch Ground
4D	NRST	Input	External Reset, Active Low
4C	SCL	Logic Input	Clock Input for I ² C Compatible Interface
4B	IKEY	Input	External Keypad LED Maximum Current Set Resistor
4A	GND_KEY	Ground	Ground for KEY LED Currents
3E	VDD2	Power	Supply Voltage 3.0...5.5 V
3D	VDDIO	Power	Supply Voltage for Digital Input/Output Buffers and Drivers
3C	SDA	Logic Input/Output	Data Input/Output for I ² C Compatible Interface
3B	GPIO[2]	Logic Input/Output	General Purpose Logic Input/Output
3A	GPIO[0] / PWM	Logic Input/Output	General Purpose Logic Input/Output / External PWM Input
2E	GND_WLED	Ground	Ground for White LED Currents (MAIN and SUB Outputs)
2D	GNDT	Ground	Ground
2C	VDD1	Power	Supply Voltage 3.0...5.5 V
2B	VREF	Output	Reference Voltage (1.23V)
2A	GPIO[1]	Logic Input/Output	General Purpose Logic Input/Output
1E	MAIN	Output	MAIN Display White LED Current Output (Current Sink)
1D	SUB	Output	SUB Display White LED Current Output (Current Sink)
1C	VDDA	Output	Internal LDO Output (2.80V)
1B	GND	Ground	Ground for Core Circuitry
1A	IRT	Input	Oscillator Frequency Set Resistor



These devices have limited built-in ESD protection. The leads should be shorted together or the device placed in conductive foam during storage or handling to prevent electrostatic damage to the MOS gates.

Absolute Maximum Ratings ^{(1) (2)(3)}

V (SW, FB, MAIN, SUB, KEY1, KEY2, KEY3)	-0.3V to +20V	
V _{DD1} , V _{DD2} , V _{DDIO} , V _{DDA}	-0.3V to +6.0V	
Voltage on I _{KEY} , I _{RT} , V _{REF}	-0.3V to V _{DD1} +0.3V with 6.0V max	
Voltage on Logic Pins	-0.3V to V _{DDIO} +0.3V with 6.0V max	
I (V _{REF})	10μA	
I(KEY1, KEY2, KEY3)	100mA	
Continuous Power Dissipation ⁽⁴⁾	Internally Limited	
Junction Temperature (T _{J-MAX})	125°C	
Storage Temperature Range	-65°C to +150°C	
Maximum Lead Temperature (Soldering) ⁽⁵⁾	260°C	
ESD Rating ⁽⁶⁾	Human Body Model	2kV
	Machine Model	200V

- (1) Absolute Maximum Ratings indicate limits beyond which damage to the component may occur. Operating Ratings are conditions under which operation of the device is guaranteed. Operating Ratings do not imply guaranteed performance limits. For guaranteed performance limits and associated test conditions, see the Electrical Characteristics tables.
- (2) All voltages are with respect to the potential at the GND pins.
- (3) If Military/Aerospace specified devices are required, please contact the TI Sales Office/Distributors for availability and specifications.
- (4) Internal thermal shutdown circuitry protects the device from permanent damage. Thermal shutdown engages at T_J=150°C (typ.) and disengages at T_J=130°C (typ.).
- (5) For detailed soldering specifications and information, please refer to Application Note AN1112: DSBGA Wafer Level Chip Scale Package
- (6) The Human body model is a 100pF capacitor discharged through a 1.5kΩ resistor into each pin. The machine model is a 200pF capacitor discharged directly into each pin. MIL-STD-883 3015.7

Operating Ratings ^{(1) (2)}

V (SW, FB, MAIN, SUB)	0 to +19V
V _{DD1,2}	3.0 to 5.5V
V _{DDIO}	1.65V to V _{DD1}
Recommended Load Current (KEY1, KEY2, KEY3) CC Mode	0mA to 15mA/driver
Recommended Total Boost Converter Load Current	0mA to 70mA
Junction Temperature (T _J)	-30°C to +125°C
Ambient Temperature (T _A) ⁽³⁾	-30°C to +85°C

- (1) Absolute Maximum Ratings indicate limits beyond which damage to the component may occur. Operating Ratings are conditions under which operation of the device is guaranteed. Operating Ratings do not imply guaranteed performance limits. For guaranteed performance limits and associated test conditions, see the Electrical Characteristics tables.
- (2) All voltages are with respect to the potential at the GND pins.
- (3) In applications where high power dissipation and/or poor package thermal resistance is present, the maximum ambient temperature may have to be derated. Maximum ambient temperature (T_{A-MAX}) is dependent on the maximum operating junction temperature (T_{J-MAX-OP} = 125°C), the maximum power dissipation of the device in the application (P_{D-MAX}), and the junction-to ambient thermal resistance of the part/package in the application (θ_{JA}), as given by the following equation: T_{A-MAX} = T_{J-MAX-OP} – (θ_{JA} × P_{D-MAX}).

Thermal Properties

Junction-to-Ambient Thermal Resistance(θ _{JA}) ⁽¹⁾	60 - 100°C/W
---	--------------

- (1) Junction-to-ambient thermal resistance is highly application and board-layout dependent. In applications where high maximum power dissipation exists, special care must be paid to thermal dissipation issues in board design.

Electrical Characteristics ^{(1) (2)}

Limits in standard typeface are for $T_J = 25^\circ\text{C}$. Limits in **boldface** type apply over the operating ambient temperature range ($-30^\circ\text{C} < T_A < +85^\circ\text{C}$). Unless otherwise noted, specifications apply to the LP3958 Block Diagram with: $V_{DD1,2} = 3.0 \dots 5.5\text{V}$, $C_{VDD} = C_{VDDIO} = 100\text{nF}$, $C_{OUT} = 2 \times 4.7\mu\text{F}$, $C_{IN} = 10\mu\text{F}$, $C_{VDDA} = 1\mu\text{F}$, $C_{VREF} = 100\text{nF}$, $L1 = 10\mu\text{H}$, $R_{KEY} = 8.2\text{k}\Omega$ and $R_{RT} = 82\text{k}\Omega$ ⁽³⁾.

Symbol	Parameter	Test Conditions	Min	Typ	Max	Unit
I_{VDD}	Standby supply current (V_{DD1}, V_{DD2})	NSTBY = L Register 0DH=08H ⁽⁴⁾		1.7	7	μA
	No-boost supply current (V_{DD1}, V_{DD2})	NSTBY = H, EN_BOOST = L		300	800	μA
	No-load supply current (V_{DD1}, V_{DD2})	NSTBY = H, EN_BOOST = H Autoload OFF		750	1300	μA
V_{DDA}	Output voltage of internal LDO	$I_{VDDA} = 1\text{mA}$		2.80		V
			-3		+3	%
V_{REF}	Reference voltage ⁽⁵⁾			1.23		V

- (1) All voltages are with respect to the potential at the GND pins.
- (2) Min and Max limits are guaranteed by design, test, or statistical analysis. Typical numbers are not guaranteed, but do represent the most likely norm.
- (3) Low-ESR Surface-Mount Ceramic Capacitors (MLCCs) used in setting electrical characteristics.
- (4) Boost output voltage set to 8V (08H in register 0DH) to prevent any unnecessary current consumption.
- (5) No external loading allowed for V_{REF} pin.

BLOCK DIAGRAM

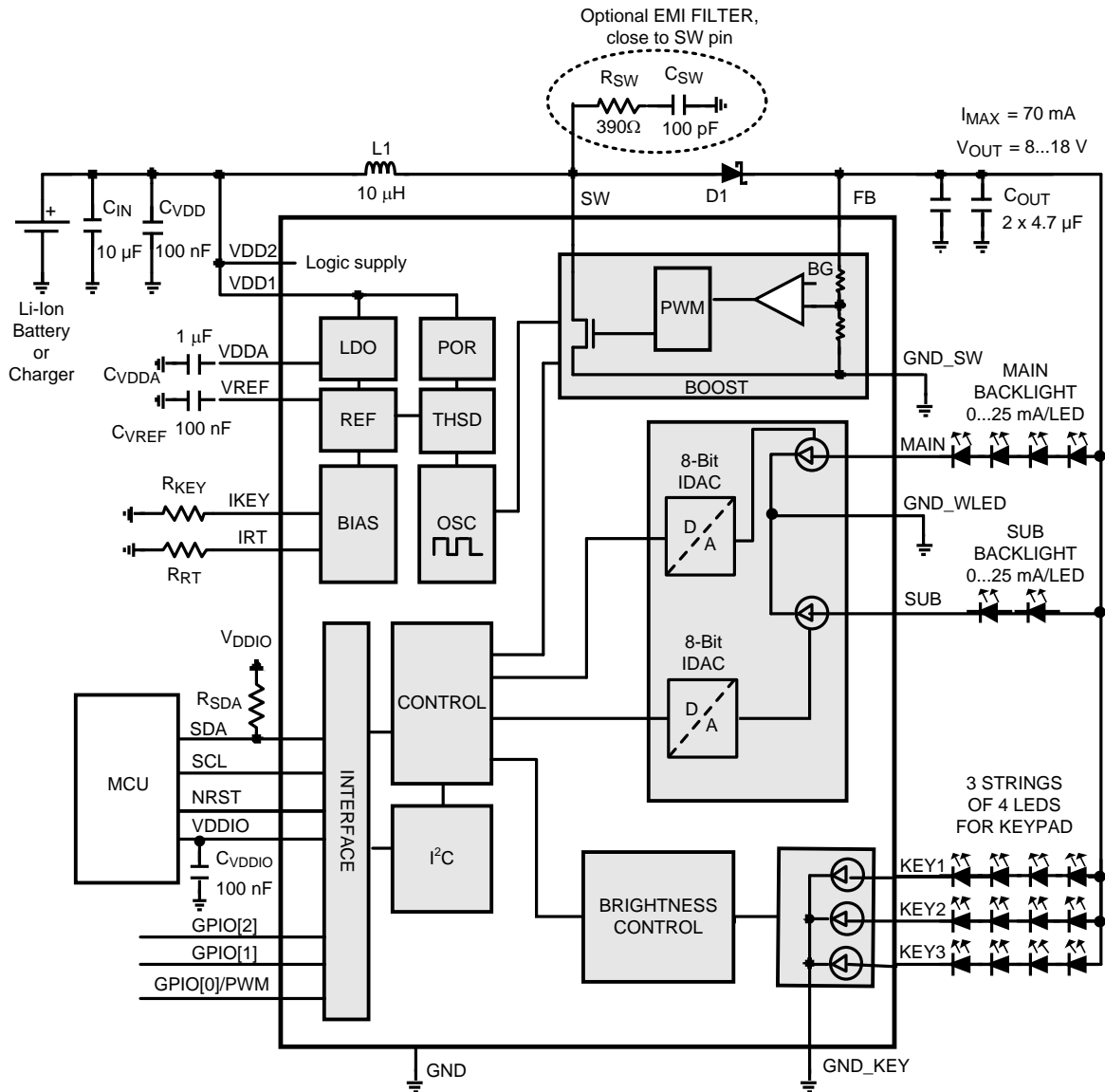

APPLICATION INFORMATION

Modes of Operation

RESET: In the RESET mode all the internal registers are reset to the default values. Reset is entered always if input NRST is LOW or internal Power On Reset is active. Power On Reset (POR) will activate during the chip startup or when the supply voltages V_{DD1} and V_{DD2} fall below 1.5V. Once V_{DD1} and V_{DD2} rises above 1.5V, POR will inactivate and the chip will continue to the STANDBY mode. NSTBY control bit is low after POR by default.

STANDBY: The STANDBY mode is entered if the register bit NSTBY is LOW and Reset is not active. This is the low power consumption mode, when all circuit functions are disabled. Registers can be written in this mode and the control bits are effective immediately after start up.

STARTUP: When NSTBY bit is written high, the INTERNAL STARTUP SEQUENCE powers up all the needed internal blocks (V_{REF} , Bias, Oscillator etc.). To ensure the correct oscillator initialization, a 10ms delay is generated by the internal state-machine. If the chip temperature rises too high, the Thermal Shutdown (THSD) disables the chip operation and STARTUP mode is entered until no thermal shutdown event is present.

BOOST STARTUP: Soft start for boost output is generated in the BOOST STARTUP mode. The boost output is raised in low current PWM mode during the 20ms delay generated by the state-machine. All LED outputs are off during the 20ms delay to ensure smooth startup. The Boost startup is entered from Internal Startup Sequence if EN_BOOST is HIGH or from Normal mode when EN_BOOST is written HIGH.

NORMAL: During NORMAL mode the user controls the chip using the Control Registers. The registers can be written in any sequence and any number of bits can be altered in a register in one write.

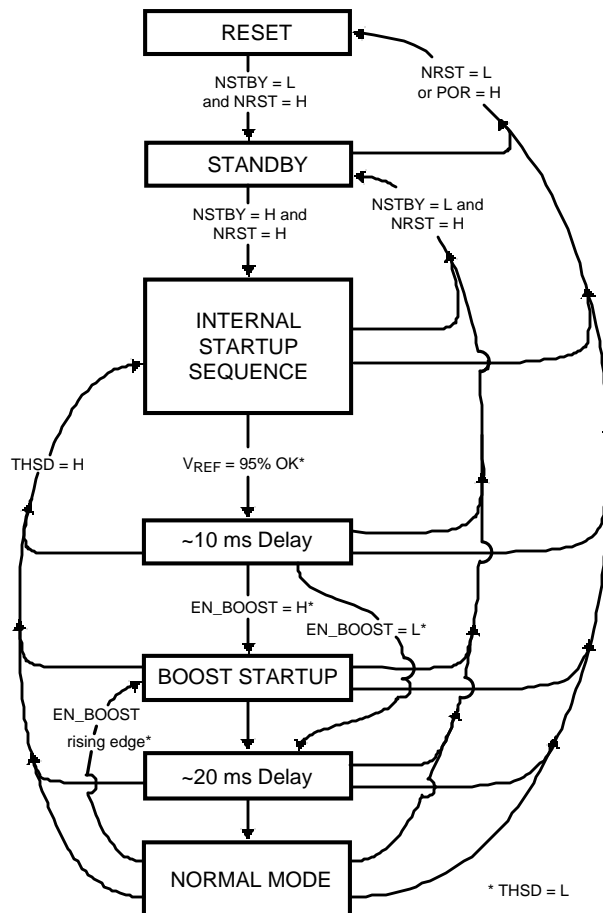

Power-Up Sequence

When powering up the device, V_{DD1} and V_{DD2} should be greater than V_{DDIO} to prevent any damage to the device.

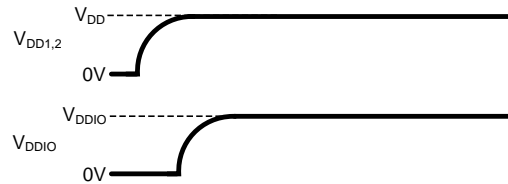

Magnetic Boost DC/DC Converter

The LP3958 Boost DC/DC Converter generates an 8...18V supply voltage for the LEDs from single Li-Ion battery (3V...4.5V). The output voltage is controlled with an 8-bit register in 10 steps. The converter is a magnetic switching PWM mode DC/DC converter with a current limit. Switching frequency is 1MHz, when timing resistor R_T is 82k Ω . Timing resistor defines the internal oscillator frequency and thus directly affects boost frequency and KEY timings.

EMI filter (R_{SW} and C_{SW}) on the SW pin can be used to suppress EMI caused by fast switching. These components should be as near as possible to the SW pin to ensure reliable operation. The LP3958 Boost Converter uses pulse-skipping elimination to stabilize the noise spectrum. Even with light load or no load a minimum length current pulse is fed to the inductor. An active load is used to remove the excess charge from the output capacitor at very light loads. Active load can be disabled with the EN_AUTOLOAD bit. Disabling active load will increase slightly the efficiency at light loads, but the downside is that pulse skipping will occur. The Boost Converter should be stopped when there is no load to minimise the current consumption.

The topology of the magnetic boost converter is called CPM control, current programmed mode, where the inductor current is measured and controlled with the feedback. The user can program the output voltage of the boost converter. The output voltage control changes the resistor divider in the feedback loop. [Figure 3](#) shows the boost topology with the protection circuitry. Four different protection schemes are implemented:

1. Over voltage protection, limits the maximum output voltage
 - Keeps the output below breakdown voltage.
 - Prevents boost operation if battery voltage is much higher than desired output.
2. Over current protection, limits the maximum inductor current
 - Voltage over switching NMOS is monitored; too high voltages turn the switch off.
3. Feedback break protection. Prevents uncontrolled operation if FB pin gets disconnected.
4. Duty cycle limiting, done with digital control.

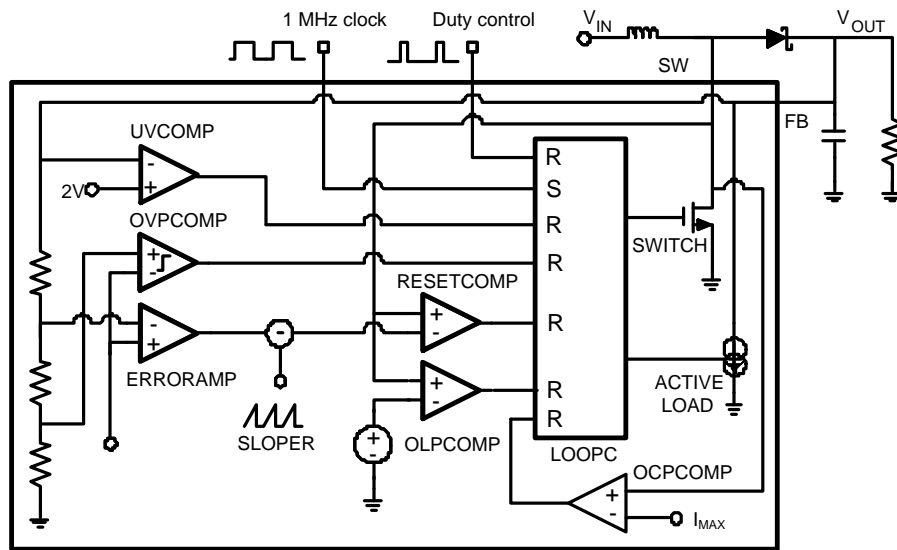

Figure 3. Boost Converter Topology

MAGNETIC BOOST DC/DC CONVERTER ELECTRICAL CHARACTERISTICS

Symbol	Parameter	Test Conditions	Min	Typ	Max	Unit
I_{LOAD}	Maximum Continuous Load Current	$3.0V = V_{IN}$ $V_{OUT} = 18V$			70	mA
V_{OUT}	Output Voltage Accuracy (FB Pin)	$3.0V \leq V_{IN} \leq 5.5V$ $V_{OUT} = 18V$	-3.5		+3.5	%
$R_{DS_{ON}}$	Switch ON Resistance	$I_{SW} = 0.5A$		0.15	0.3	Ω
f_{PWM}	PWM Mode Switching Frequency	$R_T = 82\ k\Omega$		1.0		MHz
	Frequency Accuracy	$R_T = 82\ k\Omega$	-7		+7	%
t_{PULSE}	Switch Pulse Minimum Width	no load		45		
$t_{STARTUP}$	Startup Time	Boost startup from STANDBY to $V_{OUT} = 18V$, no load		15		ms
I_{MAX}	SW Pin Current Limit			800	1150	mA

BOOST STANDBY MODE

User can set the Boost Converter to STANDBY mode by writing the register bit EN_BOOST low. When EN_BOOST is written high, the converter starts for 20ms in low current PWM mode and then goes to normal PWM mode. All LED outputs are off during the 20ms delay to ensure smooth startup.

BOOST OUTPUT VOLTAGE CONTROL

User can control the boost output voltage by Boost Output 8-bit register.

Boost Output [7:0] Register 0DH		Boost Output Voltage (typical)
Bin	Dec	
0000 1000	8	8.0V
0000 1001	9	9.0V
0000 1010	10	10.0V
0000 1011	11	11.0V

0000 1100	12	12.0V
0000 1101	13	13.0V
0000 1110	14	14.0V
0000 1111	15	15.0V
0001 0000	16	16.0V
0001 0001	17	17.0V
0001 0010	18	18.0V

If register value is lower than 8, then value of 8 is used internally.

If register value is higher than 18, then value of 18 is used internally.

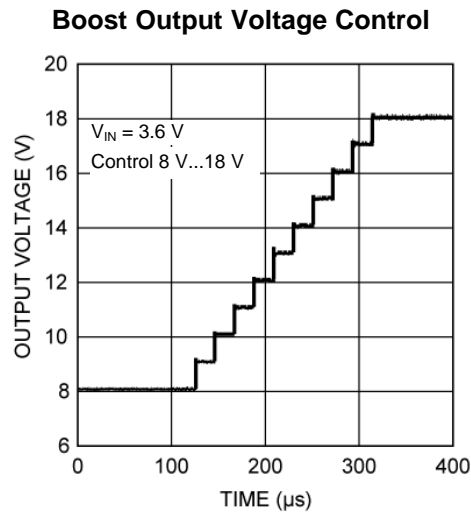

Figure 4.

Boost Converter Typical Performance Characteristics

$V_{in} = 3.6\text{V}$, $V_{out} = 18.0\text{V}$ if not otherwise stated

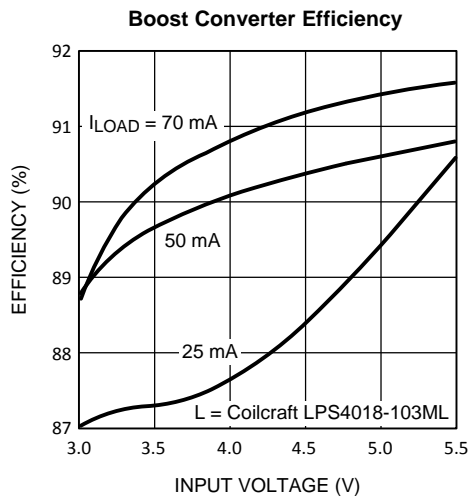

Figure 5.

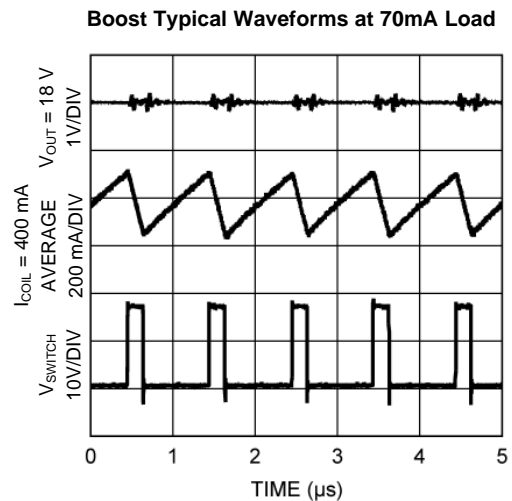

Figure 6.

V_{in} = 3.6V, V_{out} = 18.0V if not otherwise stated

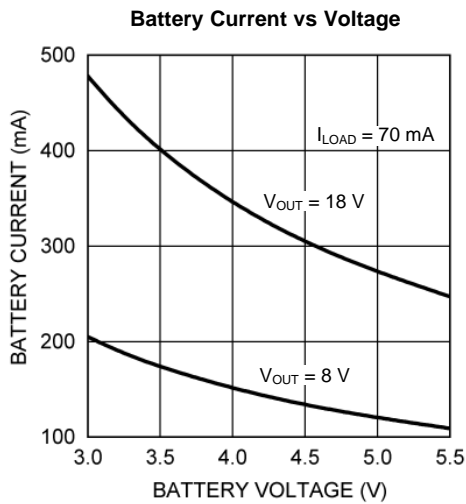

Figure 7.

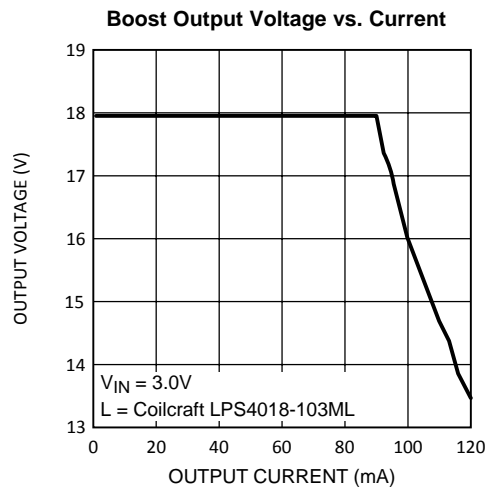

Figure 8.

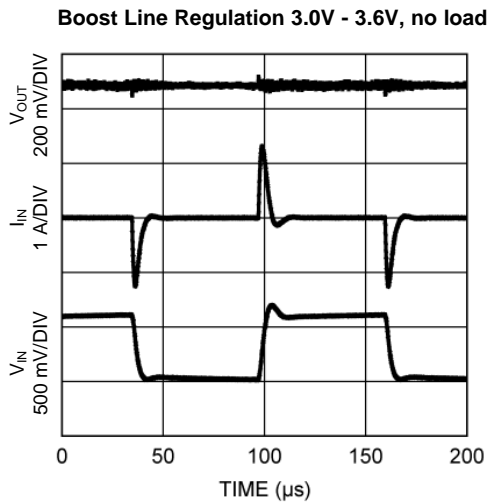

Figure 9.

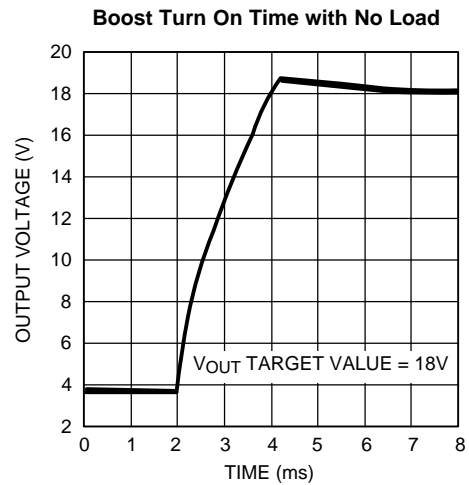

Figure 10.

V_{in} = 3.6V, V_{out} = 18.0V if not otherwise stated

Boost Load Transient Response 25mA – 70mA

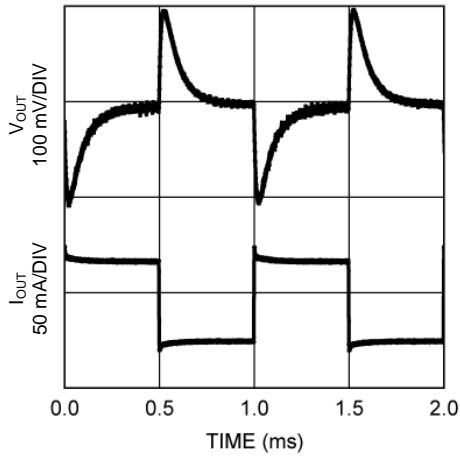

Figure 11.

Autoload Effect on Input Current, No Load

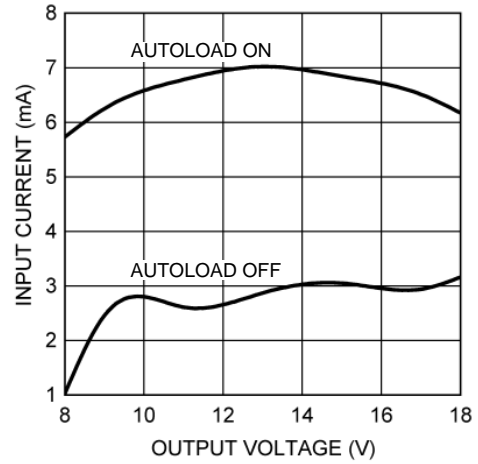

Figure 12.

Boost Maximum Current vs. Output Voltage

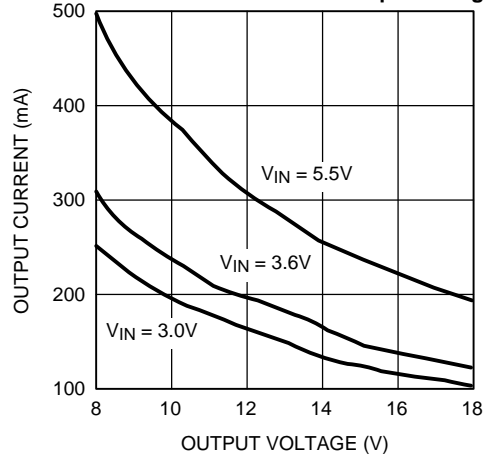

Figure 13.

Vin = 3.6V, Vout = 18.0V if not otherwise stated

Functionality of Keypad LED Outputs (KEY1, KEY2, KEY3)

LP3958 has three individual keypad LED output pins. Output pins can be used in switch mode or constant current mode. Output mode can be selected with the control register (address 00H) bit CC_SW. If the bit is set high, then keypad LED outputs are in switch mode, otherwise in constant current mode. These modes are described later in separate chapters.

Keypad LED output control can be done in three ways:

1. Defining the expected balance and brightness in Keypad register (address 01H)
2. Direct setting each LED ON/OFF via Keypad control register (address 00H)
3. External PWM control

BRIGHTNESS CONTROL WITH KEYPAD REGISTER

If the keypad LED output is used by defining the balance and brightness in the Keypad register, then one needs to set EN_KEYP bit high and KEYP_PWM bit high in the Control register (address 00H). K1SW, K2SW and K3SW are used to enable each LED output, enabled when written high. CC_SW defines the LED output mode. A single register is used for defining the balance and brightness for keypad LED output:

KEYPAD REGISTER (01H)		
Name	Bit	Description
BALANCE[2:0]	6:4	Balance of KEY1, KEY2 and KEY3 outputs
BRIGHT[2:0]	3:1	Brightness control
OVL	0	Overlapping mode selection: 0 = non-overlapping mode 1 = overlapping mode

Brightness control is logarithmic and is programmed as follows:

Table 2.

Bright[2:0]	Brightness [%]	Ratio to max brightness
000	0	0
001	1.56	1/64
010	3.12	1/32
011	6.25	1/16
100	12.5	1/8
101	25	1/4
110	50	1/2
111	100	1/1

The LED balance can be selected as follows. This is valid only in non-overlapping mode.

Table 3.

Balance [2:0]	KEY1 active [%]	KEY2 active [%]	KEY3 active [%]
000	100	0	0
001	0	100	0
010	0	0	100
011	50	50	0
100	0	50	50
101	50	0	50
110	33	33	33
111	50	25	25

OVERLAPPING MODE

The brightness is controlled using PWM duty cycle based control method as [Figure 14](#) shows.

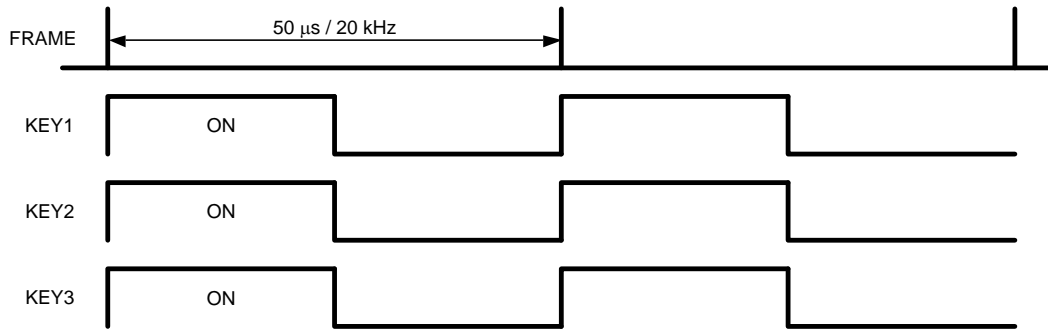

Figure 14. Overlapping Mode

Since KEY outputs are on simultaneously, the maximum load peak current is:

$$I_{MAX} = I(KY1)_{MAX} + I(KY2)_{MAX} + I(KY3)_{MAX} \quad (1)$$

NON-OVERLAPPING MODE

The timing diagram shows the splitted KEY1, KEY2 and KEY3 and brightness control effect to splitted parts. Full brightness is used in the diagram. If for example ½ brightness is used, the frame is still 50μs, but all LED outputs' ON time is 50% shorter and at the last 25μs all LED outputs are OFF.

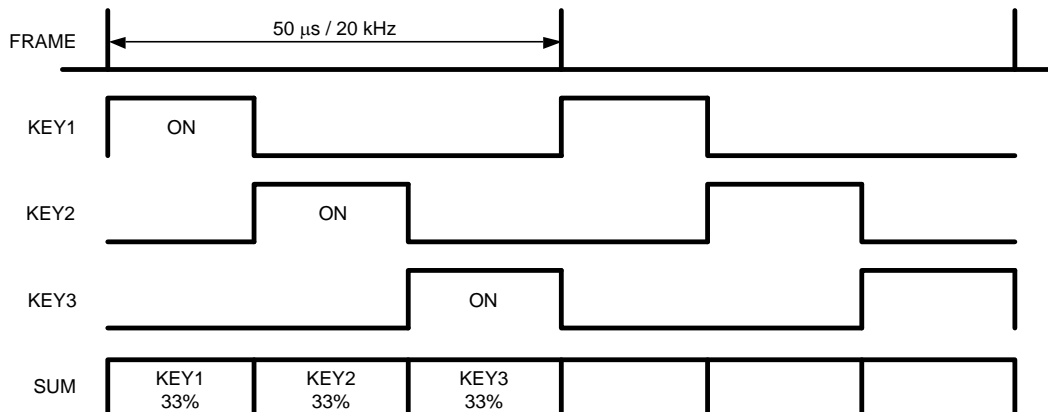

Figure 15. Non-overlapping Mode

The non-overlapping mode has 8-programmed balance ratios. Since the KEY1, KEY2 and KEY3 are split in to non-overlapping slots the output current through the keypad LED can be calculated by following equation:

$$I_{AVG} = (C_{KEY1} \times I_{KEY1} + C_{KEY2} \times I_{KEY2} + C_{KEY3} \times I_{KEY3}) \times B$$

where

- C = Balance [%] (see [Table 3](#))
- B = Brightness [%] (see [Table 2](#))

(2)

LED ON/OFF CONTROL WITH KEYPAD CONTROL REGISTER

Each LED output can be set ON by writing the corresponding bit high in the control register. K1SW controls KEY1, K2SW controls KEY2 and K3SW controls KEY3 output. Note that EN_KEYP bit must be high and KEYP_PWM bit low. In this mode, the KEYPAD register does not have any effect. CC_SW bit in control register defines the LED output mode.

Switch Mode / Constant Current Mode

Each keypad LED output can be set to act as a switch or a constant current sink. Selection of mode is done with the CC_SW bit in the Control Register. If bit is set high, then the switch mode is selected. Default is switch mode.

1. SWITCH MODE

In switch mode, the keypad LED outputs are low ohmic switches to ground. Resistance is typically 3.5Ω. **External ballast resistors must be used to limit the current through the LED.**

2. CONSTANT CURRENT MODE

In constant current mode, the maximum output current is defined with a single external resistor (R_{KEY}) and the maximum current control register (address 02H).

KEYPAD MAX CURRENT REGISTER (02H)		
Name	Bit	Description
IK1[1:0]	5:4	KEY1 maximum current
IK2[1:0]	3:2	KEY2 maximum current
IK3[1:0]	1:0	KEY3 maximum current

Maximum current for each LED output is adjusted with the Keypad max current register in following way:

IK1[1:0], IK2[1:0], IK3[1:0]	Maximum current / output
00	$0.25 \times I_{MAX}$
01	$0.50 \times I_{MAX}$
10	$0.75 \times I_{MAX}$
11	$1.00 \times I_{MAX}$

External ballast resistors are not needed in this mode. The maximum current for all keypad LED drivers is set with R_{KEY} . The equation for calculating the maximum current is:

$$I_{MAX} = 100 \times 1.23V / (R_{KEY} + 50 \Omega)$$

where

- I_{MAX} = maximum KEY current in any KEY output (during constant current mode)
- 1.23V = reference voltage
- 100 = internal current mirror multiplier
- R_{KEY} = resistor value in Ohms
- 50 Ω = Internal resistor in the I_{KEY} input

(3)

Table with example resistance values and corresponding output currents:

KEY resistor R_{KEY} (kΩ)	Maximum current / output I_{MAX} (mA)
8.2	14.9
9.1	13.4
10	12.2
12	10.2
15	8.2
18	6.8
24	5.1

Note that the LED output requires a minimum saturation voltage in order to act as a true constant current sink. The saturation voltage minimum is typically 100mV. If the LED output voltage drops below 100mV, then the current will decrease significantly.

External PWM Control

The GPIO[0]/PWM pin can be used to control the KEY output. PWM function for the pin is selected by writing EN_PWM_PIN high in GPIO control register (address 06H). Note, that EN_KEYP bit must be set high. Each LED output can be enabled with K1SW, K2SW and K3SW bits. EN_EXT_K1_PWM, EN_EXT_K2_PWM and EN_EXT_K3_PWM bits are used to select, which LED outputs are controlled with the external PWM input. Note that polarity of external PWM control is active high i.e. when high, then LED output is enabled. If KEYP_PWM is set low, then each selected LED output is controlled directly with external PWM input. If KEYP_PWM is set high, then internal PWM control is modulated by the external PWM input. In latter case, internal PWM control is passed to LED when external PWM input is high.

Keypad LEDs Driver Performance Characteristics

Symbol	Parameter	Test Conditions	Min	Typ	Max	Unit
$I_{LEAKAGE}$	KEY1, KEY2, KEY3 pin leakage current				1	μA
$I_{MAX(KEY)}$	Maximum recommended sink current ⁽¹⁾	CC mode			15	mA
		SW mode			60	mA
	Accuracy at 15mA	CC mode		5		%
	Current mirror ratio	CC mode		1:100		
	KEY current matching error	I_{KEY} set to 15mA, CC mode		3		%
R_{SW}	Switch resistance	SW mode		3.5		Ω
f_{KEY}	KEY internal PMW switching frequency	Accuracy same as internal clock frequency accuracy		20		kHz
V_{SAT}	Saturation voltage (current drop 10%)	I_{KEY} set to 15mA		100	500	mV

- (1) KEY current should be limited as follows:
constant current mode – limited by external R_{KEY} resistor
switch mode – limited by external ballast resistors

Backlight Drivers

LP3958 has 2 independent backlight drivers. Both drivers are regulated constant current sinks. LED current for both LED strings are controlled by the 8-bit current mode DACs with 0.1 mA step. MAIN and SUB LEDs can be also controlled with one DAC (MAIN) for better matching allowing the use of larger displays having up to 8 white LEDs by setting DISPL bit to 1.

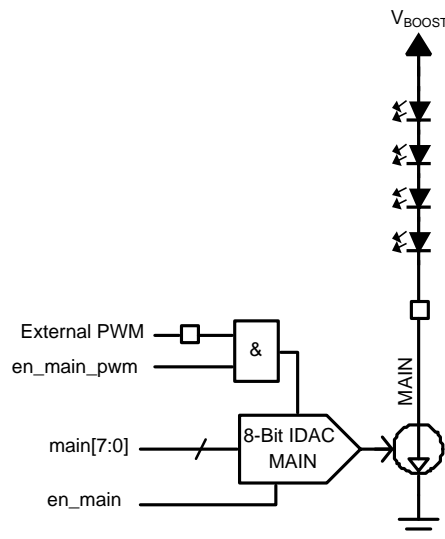

Figure 16. MAIN output for 4 LEDs (DISPL = 0)

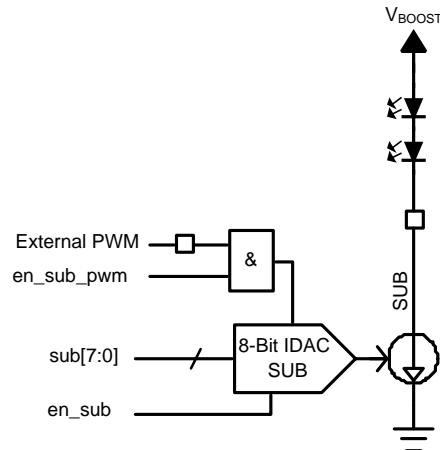

Figure 17. SUB output for 2 LEDs (DISPL = 0)

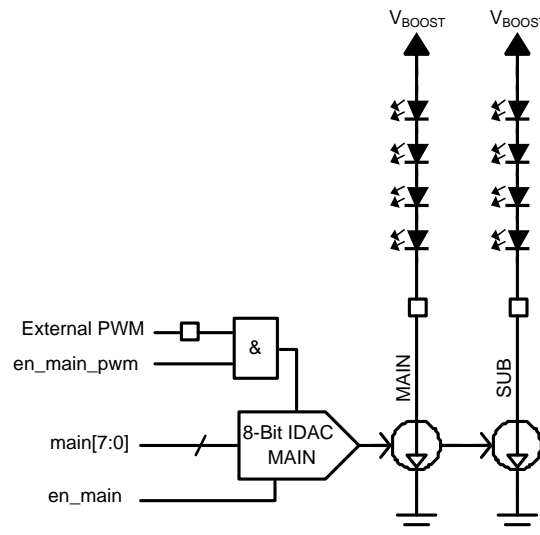

Figure 18. MAIN and SUB outputs for 8 LEDs (DISPL = 1)

PWM CONTROL

External PWM control is enabled by writing 1 to EN_MAIN_PWM and/or EN_SUB_PWM bits in register address 2BH. GPIO[0] pin is used as external PWM input when EN_PWM_PIN is set high. PWM input is active high, i.e. LED is activated when in high state.

FADE IN / FADE OUT

LP3958 has an automatic fade in and out for main and sub backlight. The fade function is enabled with EN_FADE bit. The slope of the fade curve is set by the SLOPE bit. Fade control for main and sub display is set by FADE_SEL bit.

Recommended fading sequence:

1. ASSUMPTION: Current WLED value in register
2. Set SLOPE
3. Set FADE_SEL
4. Set EN_FADE = 1
5. Set target WLED value

6. Fading will be done either within 0.65s or 1.3s based on SLOPE selection

Fading times apply to full scale change i.e. from 0 to 100% or vice versa. If the current change does not correspond to full scale change, the time will be respectively shorter. See WLED Dimming diagrams for typical fade times.

WLED CONTROL REGISTER (03H)		
Name	Bit	Description ⁽¹⁾
SLOPE	5	FADE execution time: 0 = 1.3s (full scale) 1 = 0.65s (full scale)
FADE_SEL	4	FADE selection: 0 = FADE controls MAIN 1 = FADE controls SUB
EN_FADE	3	FADE enable 0 = FADE disabled 1 = FADE enabled
DISPL	2	Display mode: 0 = MAIN and SUB individual control 1 = MAIN and SUB controlled with MAIN DAC
EN_MAIN	1	MAIN enable: 0 = disable 1 = enable
EN_SUB	0	SUB enable: 0 = disable 1 = enable

(1) If DISPL=1 and FADE_SEL=0 then FADE effects MAIN and SUB

Adjustment is made with 04H (main current) and with 05H (sub current) registers:

MAIN CURRENT [7:0] SUB CURRENT [7:0]	Driver current, mA (typical)
0000 0000	0
0000 0001	0.1
0000 0010	0.2
0000 0011	0.3
...	...
...	...
1111 1101	25.3
1111 1110	25.4
1111 1111	25.5

Backlight Driver Electrical Characteristics

Symbol	Parameter	Test Conditions	Min	Typ	Max	Unit
I_{MAX}	Maximum Sink Current			25.5	30	mA
$I_{LEAKAGE}$	Leakage Current	$V_{SUB, MAIN} = 18V$		0.03	1	μA
I_{MAIN} I_{SUB}	MAIN Current tolerance SUB Current tolerance	I_{MAIN} and I_{SUB} set to 12.8mA (80H)	11.1	12.8	14.1	mA
Match _{MAIN-SUB}	Sink Current Matching Error ⁽¹⁾	$I_{SINK} = 12.8mA$, DISPL=1		0.2		%
Match _{MAIN-SUB}	Sink Current Matching Error	$I_{SINK} = 12.8mA$, DISPL=0		5		%
V_{SAT}	95% Saturation Voltage	$I_{SINK} = 25mA$		400	600 800	mV

(1) Matching is the maximum difference from the average.

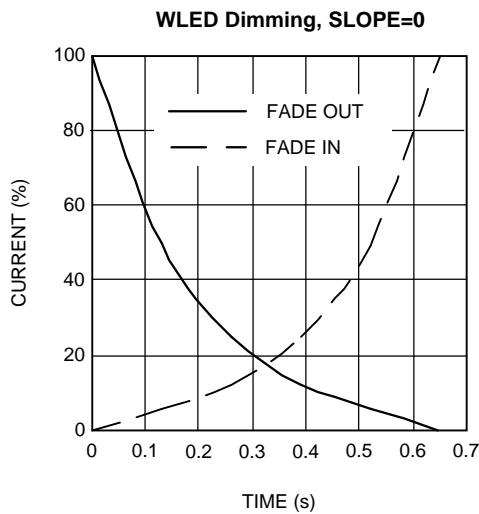

Figure 19.

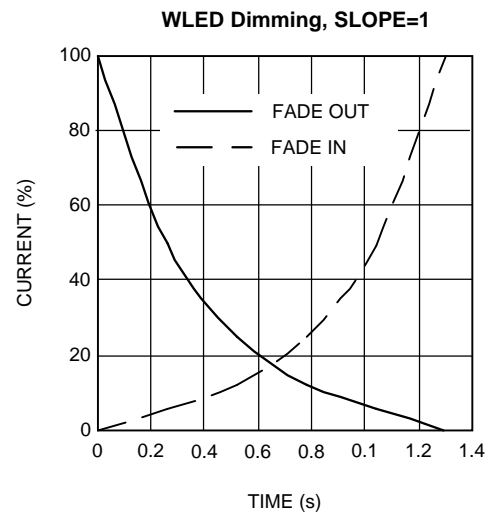

Figure 20.

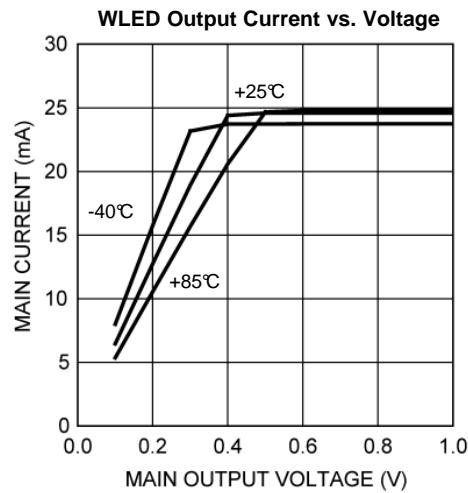

Figure 21.

General Purpose I/O Functionality

LP3958 has three general purpose I/O pins: GPIO[0]/PWM, GPIO[1] and GPIO[2]. GPIO[0]/PWM can also be used as a PWM input for the external LED PWM controlling. GPIO bi-directional drivers are operating from the V_{DDIO} supply domain.

Registers for GPIO are as follows:

GPIO CONTROL (06H)		
Name	Bit	Description
EN_PWM_PIN	4	Enable PWM pin 0 = disable 1 = enable
OEN[2:0]	2:0	GPIO pin direction 0 = input 1 = output

GPIO DATA (07H)		
Name	Bit	Description
DATA[2:0]	2:0	Data bits

GPIO control register is used to set the direction of each GPIO pin. For example, by setting OEN0 bit high the GPIO[0]/PWM pin acts as a logic output pin with data defined DATA0 in GPIO data register. Note, that the EN_PWM_PIN bit overrides OEN0 state by forcing GPIO[0]/PWM to act as PWM input. GPIO[1] and GPIO[2] pins can be selected to be inputs or outputs, defined by OEN1 and OEN2 bit status. PWM functionality is valid only for GPIO[0]/PWM pin. GPIO data register contains the data of GPIO pins. When output direction is selected to GPIO pin, then GPIO data register defines the output pin state. When GPIO data register is read, it contains the state of the pin despite of the pin direction.

Table 4. Logic Interface Characteristics ($V_{DDIO} = 1.65V \dots V_{DD1,2}$ unless otherwise noted)

Symbol	Parameter	Test Conditions	Min	Typ	Max	Unit
LOGIC INPUT SCL, SDA, GPIO[0:2]						
V_{IL}	Input Low Level				$0.2 \times V_{DDIO}$	V
V_{IH}	Input High Level		$0.8 \times V_{DDIO}$			V
I_I	Logic Input Current		-1.0		1.0	μA
f_{SCL}	Clock Frequency				400	kHz
LOGIC INPUT NRST						
V_{IL}	Input Low Level				0.5	V
V_{IH}	Input High Level		1.2			V
I_I	Input Current		-1.0		1.0	μA
t_{NRST}	Reset Pulse Width		10			μs
LOGIC OUTPUT SDA						
V_{OL}	Output Low Level	$I_{SDA} = 3mA$		0.3	0.5	V
V_{OH}	Output High Level	$I_{SDA} = -3mA$	$V_{DDIO} - 0.5$	$V_{DDIO} - 0.3$		V
I_L	Output Leakage Current	$V_{SDA} = 2.8V$			1.0	μA
LOGIC OUTPUT GPIO[0:2]						
V_{OL}	Output Low Level	$I_{GPIO} = 3mA$		0.3	0.5	V
V_{OH}	Output High Level	$I_{GPIO} = -3mA$	$V_{DDIO} - 0.5$	$V_{DDIO} - 0.3$		V
I_L	Output Leakage Current	$V_{GPIO} = 2.8V$			1.0	μA

I²C Compatible Interface

I²C SIGNALS

The SCL pin is used for the I²C clock and the SDA pin is used for bidirectional data transfer. Both these signals need a pull-up resistor according to I²C specification.

I²C DATA VALIDITY

The data on SDA line must be stable during the HIGH period of the clock signal (SCL). In other words, state of the data line can only be changed when CLK is LOW.

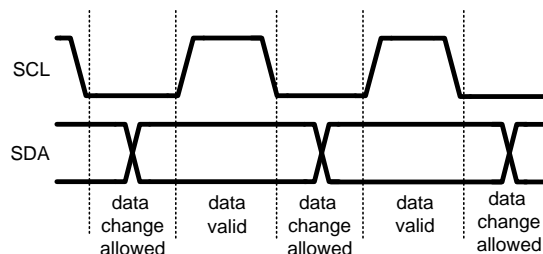

Figure 22. I²C Signals: Data Validity

I²C START AND STOP CONDITIONS

START and STOP bits classify the beginning and the end of the I²C session. START condition is defined as SDA signal transitioning from HIGH to LOW while SCL line is HIGH. STOP condition is defined as the SDA transitioning from LOW to HIGH while SCL is HIGH. The I²C master always generates START and STOP bits. The I²C bus is considered to be busy after START condition and free after STOP condition. During data transmission, I²C master can generate repeated START conditions. First START and repeated START conditions are equivalent, function-wise.

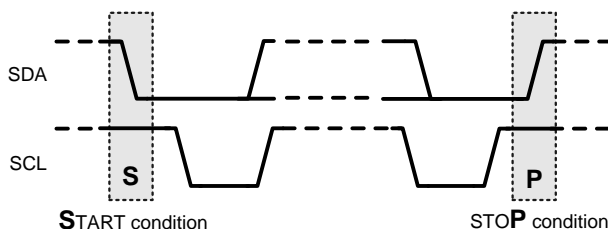

Figure 23. I²C Start and Stop Conditions

TRANSFERRING DATA

Every byte put on the SDA line must be eight bits long, with the most significant bit (MSB) being transferred first. Each byte of data has to be followed by an acknowledge bit. The acknowledge related clock pulse is generated by the master. The transmitter releases the SDA line (HIGH) during the acknowledge clock pulse. The receiver must pull down the SDA line during the 9th clock pulse, signifying an acknowledge. A receiver which has been addressed must generate an acknowledge after each byte has been received.

After the START condition, the I²C master sends a chip address. This address is seven bits long followed by an eighth bit which is a data direction bit (R/W). The LP3958 address is 59H (101 1001b). For the eighth bit, a “0” indicates a WRITE and a “1” indicates a READ. This means that the first byte is B2H for WRITE and B3H for READ. The second byte selects the register to which the data will be written. The third byte contains data to write to the selected register.

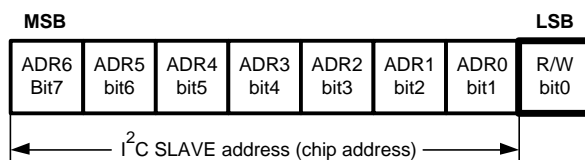
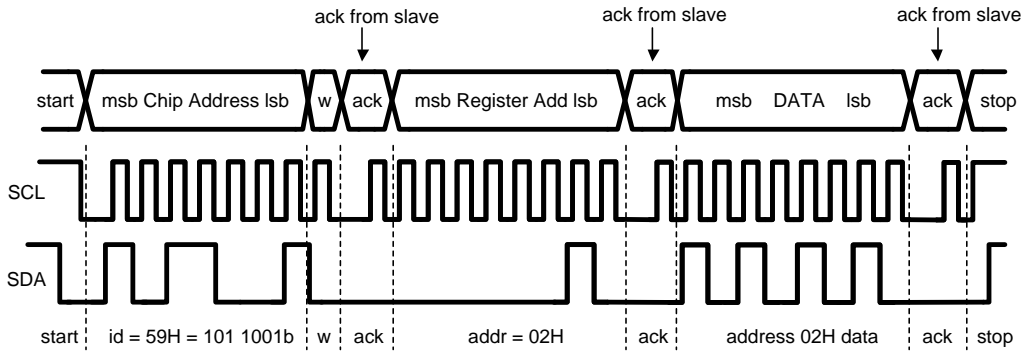

Figure 24. I²C Chip Address

Register changes take an effect at the SCL rising edge during the last ACK from slave.



w = write (SDA = "0")
 r = read (SDA = "1")
 ack = acknowledge (SDA pulled down by either master or slave)
 rs = repeated start
 id = 7-bit chip address, 59H (101 1001b) for LP3958.

Figure 25. I²C Write Cycle

When a READ function is to be accomplished, a WRITE function must precede the READ function, as shown in the Read Cycle waveform.

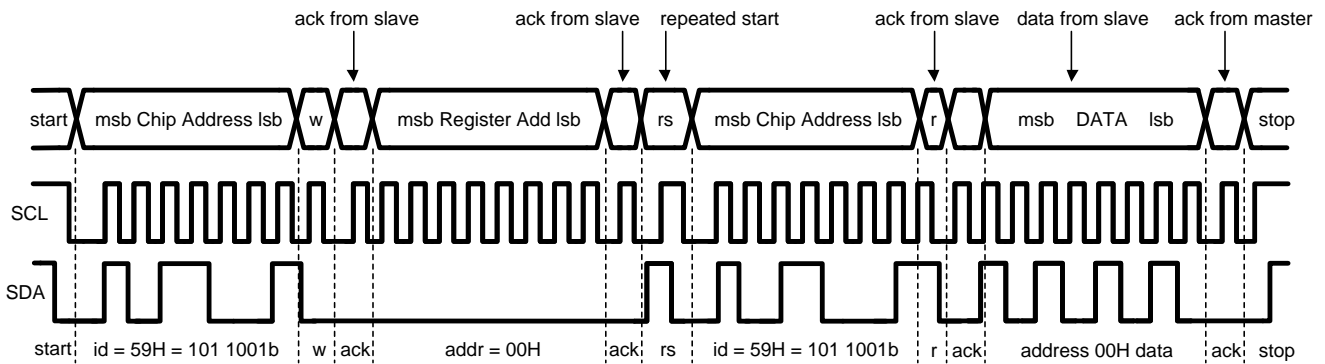

Figure 26. I²C Read Cycle

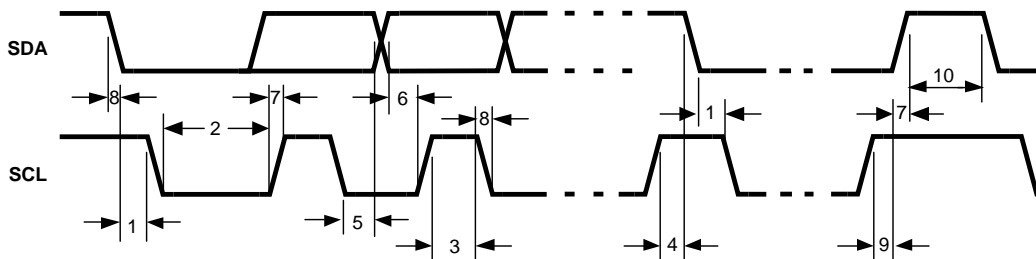

Figure 27. I²C Timing Diagram

I²C TIMING PARAMETERS ($V_{DD1,2} = 3.0$ to $4.5V$, $V_{DDIO} = 1.8V$ to $V_{DD1,2}$)

Symbol	Parameter	Limit ⁽¹⁾		Unit
		Min	Max	
1	Hold Time (repeated) START Condition	0.6		μs

(1) Data guaranteed by design

Symbol	Parameter	Limit ⁽¹⁾		Unit
		Min	Max	
2	Clock Low Time	1.3		μs
3	Clock High Time	600		ns
4	Setup Time for a Repeated START Condition	600		ns
5	Data Hold Time (Output direction, delay generated by LP3958)	300	900	ns
5	Data Hold Time (Input direction, delay generated by Master)	0	900	ns
6	Data Setup Time	100		ns
7	Rise Time of SDA and SCL	20+0.1C _b	300	ns
8	Fall Time of SDA and SCL	15+0.1C _b	300	ns
9	Set-up Time for STOP condition	600		ns
10	Bus Free Time between a STOP and a START Condition	1.3		μs
C _b	Capacitive Load for Each Bus Line	10	200	pF

Recommended External Components

OUTPUT CAPACITOR, C_{OUT}

The output capacitor C_{OUT} directly affects the magnitude of the output ripple voltage. In general, the higher the value of C_{OUT}, the lower the output ripple magnitude. Multilayer ceramic capacitors with low ESR are the best choice. At the lighter loads, the low ESR ceramics offer a much lower V_{OUT} ripple than the higher ESR tantalums of the same value. At the higher loads, the ceramics offer a slightly lower V_{OUT} ripple magnitude than the tantalums of the same value. However, the dv/dt of the V_{OUT} ripple with the ceramics is much lower than the tantalums under all load conditions. Capacitor voltage rating must be sufficient, 25V or greater is recommended. Examples of suitable capacitors are: TDK C3216X5R1E475K, Panasonic ECJ3YB1E475K, ECJMFB1E475K and ECJ4YB1E475K.

Some ceramic capacitors, especially those in small packages, exhibit a strong capacitance reduction with the increased applied voltage (DC bias effect). The capacitance value can fall below half of the nominal capacitance. Too low output capacitance can make the boost converter unstable. Output capacitors DC bias effect should be better than –50% at 18V.

INPUT CAPACITOR, C_{IN}

The input capacitor C_{IN} directly affects the magnitude of the input ripple voltage and to a lesser degree the V_{OUT} ripple. A higher value C_{IN} will give a lower V_{IN} ripple. Capacitor voltage rating must be sufficient, 10V or greater is recommended.

OUTPUT DIODE, D₁

A schottky diode should be used for the output diode. Peak repetitive current should be greater than inductor peak current (800mA) to ensure reliable operation. Schottky diodes with a low forward drop and fast switching speeds are ideal for increasing efficiency in portable applications. Choose a reverse breakdown voltage of the schottky diode significantly larger (~30V) than the output voltage. Do not use ordinary rectifier diodes, since slow switching speeds and long recovery times cause the efficiency and the load regulation to suffer. Example of suitable diode is: Central Semiconductor CMMSH1-40.

EMI FILTER COMPONENTS C_{SW}, R_{SW}

EMI filter (R_{SW} and C_{SW}) on the SW pin can be used to suppress EMI caused by fast switching. These components should be as near as possible to the SW pin to ensure reliable operation. 50V or greater voltage rating is recommended for capacitor.

INDUCTOR, L₁

A 10uH shielded inductor is suggested for LP3958 boost converter. The inductor should have a saturation current rating higher than the rms current it will experience during circuit operation (600mA). Less than 300mΩ ESR is suggested for high efficiency and sufficient output current. Open core inductors cause flux linkage with circuit components and interfere with the normal operation of the circuit. This should be avoided. For high efficiency, choose an inductor with a high frequency core material such as ferrite to reduce the core losses. To minimize radiated noise, use a toroid, pot core or shielded core inductor. The inductor should be connected to the SW pin as close to the IC as possible. Examples of suitable inductors are: TDK VLF4012AT-100MR79, VLF4018BT-100MR90, VLF5014AT-100MR92, Coilcraft LPS4018-103ML.

LIST OF RECOMMENDED EXTERNAL COMPONENTS

Symbol	Symbol Explanation	Value	Unit	Type
C _{VDD}	C between VDD1,2 and GND	100	nF	Ceramic, X7R / X5R
C _{VDDIO}	C between VDDIO and GND	100	nF	Ceramic, X7R / X5R
C _{VDDA}	C between VDDA and GND	1	μF	Ceramic, X7R / X5R
C _{OUT}	C between FB and GND	2 x 4.7 or 1 x 10	μF	Ceramic, X7R / X5R, tolerance ±10%
	Maximum DC bias effect @ 18V	-50	%	
C _{IN}	C between battery voltage and GND	10	μF	Ceramic, X7R / X5R
L ₁	L between SW and V _{BAT}	10	μH	Shielded inductor, low ESR
	Saturation current	600	mA	
C _{VREF}	C between V _{REF} and GND	100	nF	Ceramic, X7R / X5R
R _{KEY}	R between I _{KEY} and GND	8.2	kΩ	±1%
R _{RT}	R between I _{RT} and GND	82	kΩ	±1%
D ₁	Rectifying diode (V _f @ maxload)	0.3-0.5	V	Schottky diode
	Reverse voltage	30	V	
	Repetitive peak current	800	mA	
C _{SW}	C in EMI filter	100	pF	Ceramic, X7R / X5R, 50V
R _{SW}	R in EMI filter	390	Ω	±1%
LEDs		User Defined		

Note: See Application Note AN-1436 "Design and Programming Examples for Lighting Management Unit LP3958" for more information on how to design with LP3958

Table 5. LP3958 Control Register Names and Default Values

ADDR (HEX)	REGISTER	D7	D6	D5	D4	D3	D2	D1	D0
00	Control Register	KEYP_PWM	EN_KEYP	CC_SW		K1SW	K2SW	K3SW	
		0	0	1		0	0	0	
01	Keypad	BALANCE[2:0]			BRIGHT[2:0]			OVL	
			0	0	0	0	0	0	0
02	Keypad Max Current	IK1[1:0]		IK2[1:0]		IK3[1:0]			
				0	0	0	0	0	0
03	WLED Control	SLOPE		FADE_SEL	EN_FADE	DISPL	EN_MAIN	EN_SUB	
				0	0	0	0	0	
04	MAIN Current	MAIN[7:0]							
		0	0	0	0	0	0	0	0
05	SUB Current	SUB[7:0]							
		0	0	0	0	0	0	0	0
06	GPIO Control				EN_PWM_PIN	OEN[2:0]			
					0		0	0	0
07	GPIO Data							DATA[2:0]	
							0	0	0
0B	Enables	NSTBY		EN_BOOST	EN_AUTOLOAD				
			0	0			1		
0D	Boost Output	BOOST[7:0]							
		0	0	0	0	1	0	0	0
2B	PWM Enable				EN_EXT_K1_PWM	EN_EXT_K2_PWM	EN_EXT_K3_PWM	EN_MAIN_PWM	EN_SUB_PWM
					0	0	0	0	0

LP3958 Register Bit Explanations

Each register is shown with a key indicating the accessibility of the each individual bit, and the initial condition:

Table 6. Register Bit Accessibility and Initial Condition

Key	Bit Accessibility
RW	Read/write
R	Read only
–0,–1	Condition after POR

CONTROL REGISTER (00H) – KEYPAD LEDS CONTROL REGISTER

D7	D6	D5	D4	D3	D2	D1	D0
KEYP_PWM	EN_KEYP	CC_SW		K1SW	K2SW	K3SW	
RW - 0	RW - 0	RW - 1	R - 0	RW - 0	RW - 0	RW - 0	R - 0

KEYP_PWM	Bit 7	0 - Internal KEYPAD PWM control disabled 1 - Internal KEYPAD PWM control enabled
EN_KEYP	Bit 6	0 – KEYPAD outputs disabled 1 – KEYPAD outputs enabled
CC_SW	Bit 5	0 – Constant current sink mode 1 – Switch mode
K1SW	Bit 3	0 – KEYPAD1 disabled 1 – KEYPAD1 enabled
K2SW	Bit 2	0 – KEYPAD2 disabled 1 – KEYPAD2 enabled
K3SW	Bit 1	0 – KEYPAD3 disabled 1 – KEYPAD3 enabled

KEYPAD (01H) – KEYPAD BALANCE AND BRIGHTNESS CONTROL REGISTER

D7	D6	D5	D4	D3	D2	D1	D0
	BALANCE[2:0]			BRIGHT[2:0]			OVL
R - 0	RW - 0	RW - 0	RW - 0	RW - 0	RW - 0	RW - 0	RW - 0

BALANCE[2:0]	Bits 6-4	PWM balance for KEYPAD outputs
BRIGHT[2:0]	Bits 3-1	PWM brightness control for KEYPAD outputs
OVL	Bit 0	0 – Overlapping mode disabled 1 – Overlapping mode enabled

KEYPAD MAX CURRENT (02H) – MAXIMUM KEYPAD CURRENT CONTROL REGISTER

D7	D6	D5	D4	D3	D2	D1	D0
		IK1[1:0]		IK2[1:0]		IK3[1:0]	
R - 0	R - 0	RW - 0	RW - 0	RW - 0	RW - 0	RW - 0	RW - 0

Maximum current for KEY1,2,3 driver	
IK1,2,3[1:0]	Maximum output current
00	$0.25 \times I_{MAX}$
01	$0.50 \times I_{MAX}$
10	$0.75 \times I_{MAX}$
11	$1.00 \times I_{MAX}$

WLED CONTROL (03H) – WLED CONTROL REGISTER

D7	D6	D5	D4	D3	D2	D1	D0
		SLOPE	FADE_SEL	EN_FADE	DISPL	EN_MAIN	EN_SUB
R - 0	R - 0	RW - 0	RW - 0	RW - 0	RW - 0	RW - 0	RW - 0

SLOPE	Bit 5	0 – fade execution time 0.65 sec (full scale) 1 – fade execution time 1.3 sec (full scale)
FADE_SEL	Bit 4	0 – fade control for MAIN 1 – fade control for SUB
EN_FADE	Bit 3	0 – automatic fade disabled 1 – automatic fade enabled
DISPL	Bit 2	0 - MAIN and SUB individual control 1 - MAIN and SUB controlled with MAIN DAC
EN_MAIN	Bit 1	0 – MAIN output disabled 1 – MAIN output enabled
EN_SUB	Bit 0	0 – SUB output disabled 1 – SUB output enabled

MAIN CURRENT (04H) – MAIN CURRENT CONTROL REGISTER

D7	D6	D5	D4	D3	D2	D1	D0
MAIN[7:0]							
RW - 0	RW - 0	RW - 0	RW - 0	RW - 0	RW - 0	RW - 0	RW - 0

SUB CURRENT (05H) – SUB CURRENT CONTROL REGISTER

D7	D6	D5	D4	D3	D2	D1	D0
SUB[7:0]							
RW - 0	RW - 0	RW - 0	RW - 0	RW - 0	RW - 0	RW - 0	RW - 0

MAIN, SUB current adjustment	
MAIN[7:0], SUB[7:0]	Typical driver current (mA)
0000 0000	0
0000 0001	0.1
0000 0010	0.2
0000 0011	0.3
0000 0100	0.4
...	...
1111 1101	25.3
1111 1110	25.4
1111 1111	25.5

GPIO CONTROL (06H) – GPIO CONTROL REGISTER

D7	D6	D5	D4	D3	D2	D1	D0
			EN_PWM_PIN	OEN[2:0]			
R - 0	R - 0	R - 0	RW - 0	R - 0	RW - 0	RW - 0	RW - 0

EN_PWM_PIN	Bit 4	0 – External PWM pin disabled 1 – External PWM pin enabled
OEN[2:0]	Bits 2-0	0 – GPIO pin set as a input 1 – GPIO pin set as a output

GPIO DATA (07H) – GPIO DATA REGISTER

D7	D6	D5	D4	D3	D2	D1	D0
					DATA[2:0]		
R - 0	R - 0	R - 0	R - 0	R - 0	RW - 0	RW - 0	RW - 0

DATA[2:0]	Bits 2-0	GPIO data register bits
------------------	----------	-------------------------

ENABLES (0BH) – ENABLES REGISTER

D7	D6	D5	D4	D3	D2	D1	D0
	NSTBY	EN_BOOST			EN_AUTOLOAD		
R - 0	RW - 0	RW - 0	R - 0	R - 0	RW - 1	R - 0	R - 0

NSTBY	Bit 6	0 – LP3958 standby mode 1 – LP3958 active mode
EN_BOOST	Bit 5	0 – Boost converter disabled 1 – Boost converter enabled
EN_AUTOLOAD	Bit 2	0 – Boost active load disabled 1 – Boost active load enabled

BOOST OUTPUT (0DH) – BOOST OUTPUT VOLTAGE CONTROL REGISTER

D7	D6	D5	D4	D3	D2	D1	D0
BOOST[7:0]							
RW - 0	RW - 0	RW - 0	RW - 0	RW - 1	RW - 0	RW - 0	RW - 0

BOOST output voltage adjustment	
BOOST[7:0]	Typical boost output voltage (V)
0000 1000	8.00
0000 1001	9.00
0000 1010	10.00
0000 1011	11.00
0000 1100	12.00
0000 1101	13.00
0000 1110	14.00
0000 1111	15.00
0001 0000	16.00
0001 0001	17.00
0001 0010	18.00

PWM ENABLE (2BH) – EXTERNAL PWM CONTROL REGISTER

D7	D6	D5	D4	D3	D2	D1	D0
			EN_EXT_K1_PWM	EN_EXT_K2_PWM	EN_EXT_K3_PWM	EN_MAIN_PWM	EN_SUB_PWM
R - 0	R - 0	R - 0	RW - 0	RW - 0	RW - 0	RW - 0	RW - 0

EN_EXT_K1_PWM	Bit 4	0 – External PWM control for KEY1 disabled 1 – External PWM control for KEY1 enabled
EN_EXT_K2_PWM	Bit 3	0 – External PWM control for KEY2 disabled 1 – External PWM control for KEY2 enabled
EN_EXT_K3_PWM	Bit 2	0 – External PWM control for KEY3 disabled 1 – External PWM control for KEY3 enabled

EN_EXT_MAIN_PWM	Bit 1	0 – External PWM control for MAIN disabled 1 – External PWM control for MAIN enabled
EN_EXT_SUB_PWM	Bit 0	0 – External PWM control for SUB disabled 1 – External PWM control for SUB enabled

REVISION HISTORY

Changes from Revision B (March 2013) to Revision C

Page

-
- Changed layout of National Data Sheet to TI format [28](#)
-

PACKAGING INFORMATION

Orderable Device	Status (1)	Package Type	Package Drawing	Pins	Package Qty	Eco Plan (2)	Lead/Ball Finish	MSL Peak Temp (3)	Op Temp (°C)	Top-Side Markings (4)	Samples
LP3958TL/NOPB	ACTIVE	DSBGA	YZR	25	250	Green (RoHS & no Sb/Br)	SNAGCU	Level-1-260C-UNLIM	-30 to 85	SJHB	Samples
LP3958TLX/NOPB	ACTIVE	DSBGA	YZR	25	3000	Green (RoHS & no Sb/Br)	SNAGCU	Level-1-260C-UNLIM	-30 to 85	SJHB	Samples

(1) The marketing status values are defined as follows:

ACTIVE: Product device recommended for new designs.

LIFEBUY: TI has announced that the device will be discontinued, and a lifetime-buy period is in effect.

NRND: Not recommended for new designs. Device is in production to support existing customers, but TI does not recommend using this part in a new design.

PREVIEW: Device has been announced but is not in production. Samples may or may not be available.

OBSOLETE: TI has discontinued the production of the device.

(2) Eco Plan - The planned eco-friendly classification: Pb-Free (RoHS), Pb-Free (RoHS Exempt), or Green (RoHS & no Sb/Br) - please check <http://www.ti.com/productcontent> for the latest availability information and additional product content details.

TBD: The Pb-Free/Green conversion plan has not been defined.

Pb-Free (RoHS): TI's terms "Lead-Free" or "Pb-Free" mean semiconductor products that are compatible with the current RoHS requirements for all 6 substances, including the requirement that lead not exceed 0.1% by weight in homogeneous materials. Where designed to be soldered at high temperatures, TI Pb-Free products are suitable for use in specified lead-free processes.

Pb-Free (RoHS Exempt): This component has a RoHS exemption for either 1) lead-based flip-chip solder bumps used between the die and package, or 2) lead-based die adhesive used between the die and leadframe. The component is otherwise considered Pb-Free (RoHS compatible) as defined above.

Green (RoHS & no Sb/Br): TI defines "Green" to mean Pb-Free (RoHS compatible), and free of Bromine (Br) and Antimony (Sb) based flame retardants (Br or Sb do not exceed 0.1% by weight in homogeneous material)

(3) MSL, Peak Temp. -- The Moisture Sensitivity Level rating according to the JEDEC industry standard classifications, and peak solder temperature.

(4) Multiple Top-Side Markings will be inside parentheses. Only one Top-Side Marking contained in parentheses and separated by a "~" will appear on a device. If a line is indented then it is a continuation of the previous line and the two combined represent the entire Top-Side Marking for that device.

Important Information and Disclaimer: The information provided on this page represents TI's knowledge and belief as of the date that it is provided. TI bases its knowledge and belief on information provided by third parties, and makes no representation or warranty as to the accuracy of such information. Efforts are underway to better integrate information from third parties. TI has taken and continues to take reasonable steps to provide representative and accurate information but may not have conducted destructive testing or chemical analysis on incoming materials and chemicals. TI and TI suppliers consider certain information to be proprietary, and thus CAS numbers and other limited information may not be available for release.

In no event shall TI's liability arising out of such information exceed the total purchase price of the TI part(s) at issue in this document sold by TI to Customer on an annual basis.

TAPE AND REEL INFORMATION



QUADRANT ASSIGNMENTS FOR PIN 1 ORIENTATION IN TAPE



*All dimensions are nominal

Device	Package Type	Package Drawing	Pins	SPQ	Reel Diameter (mm)	Reel Width W1 (mm)	A0 (mm)	B0 (mm)	K0 (mm)	P1 (mm)	W (mm)	Pin1 Quadrant
LP3958TL/NOPB	DSBGA	YZR	25	250	178.0	8.4	2.69	2.69	0.76	4.0	8.0	Q1
LP3958TLX/NOPB	DSBGA	YZR	25	3000	178.0	8.4	2.69	2.69	0.76	4.0	8.0	Q1

TAPE AND REEL BOX DIMENSIONS



*All dimensions are nominal

Device	Package Type	Package Drawing	Pins	SPQ	Length (mm)	Width (mm)	Height (mm)
LP3958TL/NOPB	DSBGA	YZR	25	250	210.0	185.0	35.0
LP3958TLX/NOPB	DSBGA	YZR	25	3000	210.0	185.0	35.0

YZR0025

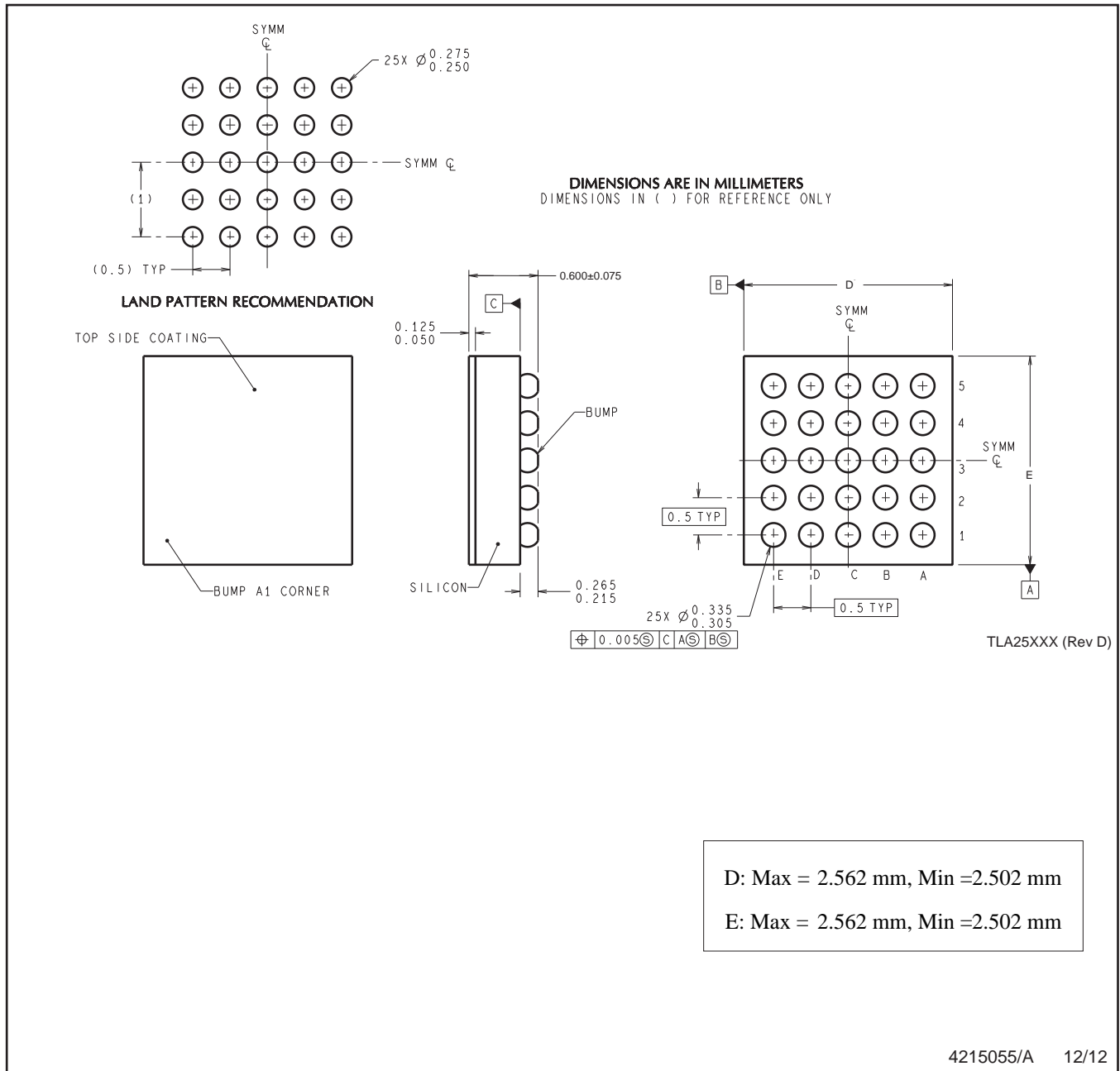

4215055/A 12/12

NOTES: A. All linear dimensions are in millimeters. Dimensioning and tolerancing per ASME Y14.5M-1994.
B. This drawing is subject to change without notice.

IMPORTANT NOTICE

Texas Instruments Incorporated and its subsidiaries (TI) reserve the right to make corrections, enhancements, improvements and other changes to its semiconductor products and services per JESD46, latest issue, and to discontinue any product or service per JESD48, latest issue. Buyers should obtain the latest relevant information before placing orders and should verify that such information is current and complete. All semiconductor products (also referred to herein as "components") are sold subject to TI's terms and conditions of sale supplied at the time of order acknowledgment.

TI warrants performance of its components to the specifications applicable at the time of sale, in accordance with the warranty in TI's terms and conditions of sale of semiconductor products. Testing and other quality control techniques are used to the extent TI deems necessary to support this warranty. Except where mandated by applicable law, testing of all parameters of each component is not necessarily performed.

TI assumes no liability for applications assistance or the design of Buyers' products. Buyers are responsible for their products and applications using TI components. To minimize the risks associated with Buyers' products and applications, Buyers should provide adequate design and operating safeguards.

TI does not warrant or represent that any license, either express or implied, is granted under any patent right, copyright, mask work right, or other intellectual property right relating to any combination, machine, or process in which TI components or services are used. Information published by TI regarding third-party products or services does not constitute a license to use such products or services or a warranty or endorsement thereof. Use of such information may require a license from a third party under the patents or other intellectual property of the third party, or a license from TI under the patents or other intellectual property of TI.

Reproduction of significant portions of TI information in TI data books or data sheets is permissible only if reproduction is without alteration and is accompanied by all associated warranties, conditions, limitations, and notices. TI is not responsible or liable for such altered documentation. Information of third parties may be subject to additional restrictions.

Resale of TI components or services with statements different from or beyond the parameters stated by TI for that component or service voids all express and any implied warranties for the associated TI component or service and is an unfair and deceptive business practice. TI is not responsible or liable for any such statements.

Buyer acknowledges and agrees that it is solely responsible for compliance with all legal, regulatory and safety-related requirements concerning its products, and any use of TI components in its applications, notwithstanding any applications-related information or support that may be provided by TI. Buyer represents and agrees that it has all the necessary expertise to create and implement safeguards which anticipate dangerous consequences of failures, monitor failures and their consequences, lessen the likelihood of failures that might cause harm and take appropriate remedial actions. Buyer will fully indemnify TI and its representatives against any damages arising out of the use of any TI components in safety-critical applications.

In some cases, TI components may be promoted specifically to facilitate safety-related applications. With such components, TI's goal is to help enable customers to design and create their own end-product solutions that meet applicable functional safety standards and requirements. Nonetheless, such components are subject to these terms.

No TI components are authorized for use in FDA Class III (or similar life-critical medical equipment) unless authorized officers of the parties have executed a special agreement specifically governing such use.

Only those TI components which TI has specifically designated as military grade or "enhanced plastic" are designed and intended for use in military/aerospace applications or environments. Buyer acknowledges and agrees that any military or aerospace use of TI components which have **not** been so designated is solely at the Buyer's risk, and that Buyer is solely responsible for compliance with all legal and regulatory requirements in connection with such use.

TI has specifically designated certain components as meeting ISO/TS16949 requirements, mainly for automotive use. In any case of use of non-designated products, TI will not be responsible for any failure to meet ISO/TS16949.

Products

Audio	www.ti.com/audio
Amplifiers	amplifier.ti.com
Data Converters	dataconverter.ti.com
DLP® Products	www.dlp.com
DSP	dsp.ti.com
Clocks and Timers	www.ti.com/clocks
Interface	interface.ti.com
Logic	logic.ti.com
Power Mgmt	power.ti.com
Microcontrollers	microcontroller.ti.com
RFID	www.ti-rfid.com
OMAP Applications Processors	www.ti.com/omap
Wireless Connectivity	www.ti.com/wirelessconnectivity

Applications

Automotive and Transportation	www.ti.com/automotive
Communications and Telecom	www.ti.com/communications
Computers and Peripherals	www.ti.com/computers
Consumer Electronics	www.ti.com/consumer-apps
Energy and Lighting	www.ti.com/energy
Industrial	www.ti.com/industrial
Medical	www.ti.com/medical
Security	www.ti.com/security
Space, Avionics and Defense	www.ti.com/space-avionics-defense
Video and Imaging	www.ti.com/video

TI E2E Community

e2e.ti.com