

# High Performance Synchronous Buck Controller with DCR Current Sensing

Check for Samples: [LM27402](#)

## FEATURES

- Input Operating Voltage Range of 3V to 20V
- Continuous Inductor DCR or Shunt Resistor Current Sensing
- 0.6V  $\pm$ 1% Reference (-40°C to 125°C Junction Temperature)
- Output Voltage as High as 95% of Input Voltage
- Integrated MOSFET Drivers
- Internal LDO Bias Supply
- External Clock Synchronization
- Adjustable Soft-Start With External Capacitor
- Pre-Biased Startup Capability
- Power Supply Tracking
- Input Voltage Feed-Forward
- Power Good Indicator
- Precision Enable With Hysteresis

## APPLICATIONS

- High Current, Low Voltage FPGA/ASIC DC/DC Converters
- General Purpose High Current Buck Converters
- Telecom, Datacom, Networking, Distributed Power Architectures

## DESCRIPTION

The LM27402 is a synchronous voltage mode DC/DC buck controller with inductor DCR current sense capability. Sensing the inductor current eliminates the need to add resistive powertrain elements which increases overall efficiency and facilitates accurate continuous current limit sensing. A 0.6V  $\pm$ 1% voltage reference enables high accuracy and low voltage capability at the output. An input operating voltage range of 3V to 20V makes the LM27402 suitable for a large variety of input rails.

The LM27402 voltage mode control loop incorporates input voltage feed-forward to maintain stability throughout the entire input voltage range. The switching frequency is adjustable from 200 kHz to 1.2 MHz. Dual high current integrated N-channel MOSFET drivers support large  $Q_G$ , low  $R_{DS(ON)}$  MOSFETs. A power good indicator provides power rail sequencing capability and output fault detection. Adjustable external soft-start capability limits inrush current and provides monotonic output control during startup. Other features include external tracking of other power supplies, integrated LDO bias supply, and synchronization capability. The LM27402 is offered in a 16 pin HTSSOP package and a 4 mm x 4 mm 16 pin exposed WQFN.

## Typical Application Circuit

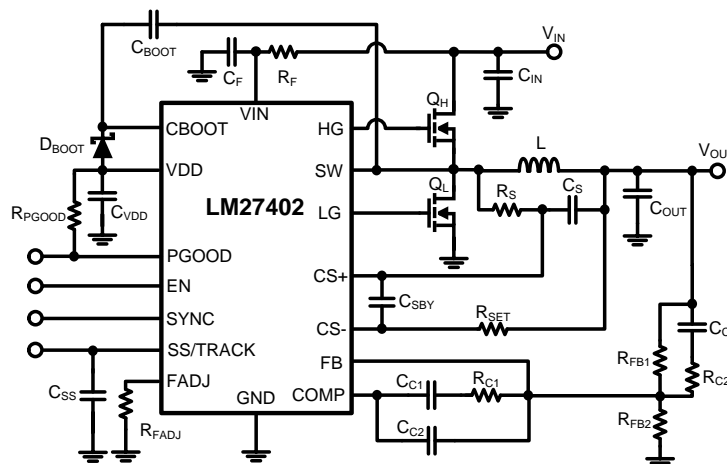

Please be aware that an important notice concerning availability, standard warranty, and use in critical applications of Texas Instruments semiconductor products and disclaimers thereto appears at the end of this data sheet.

All trademarks are the property of their respective owners.

Connection Diagram

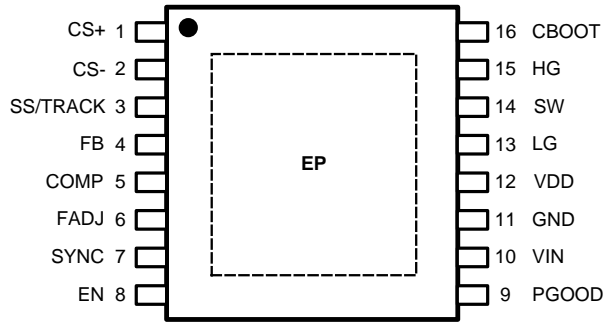

**Figure 1. Top View**  
**HTSSOP-16**  
**4.4 mm x 5 mm x 0.9 mm**  
**0.65 mm PITCH**

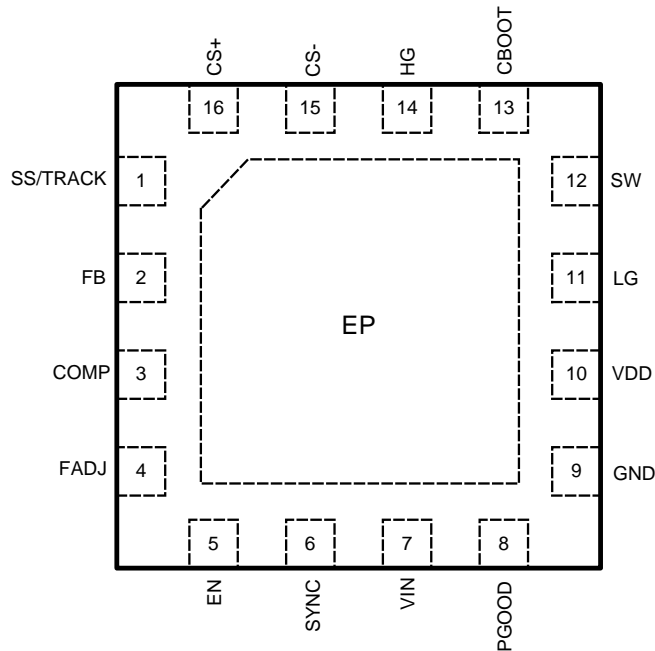

**Figure 2. Top View**  
**WQFN-16**  
**4 mm x 4 mm x 0.8 mm**  
**0.65 mm PITCH**

**PIN DESCRIPTIONS**

HTSSOP Pin No.	WQFN Pin No.	Name	Description
1	16	CS+	Non-inverting input to the current sense comparator.
2	15	CS-	Inverting input to the current sense comparator with +10 $\mu$ A offset current for adjustable current limit setpoint.
3	1	SS/TRACK	Soft-start or tracking input. A startup rate can be defined with the use of an external soft-start capacitor from SS/TRACK to GND. A +3 $\mu$ A current source charges the soft-start capacitor to set the output voltage rise time during startup. SS/TRACK can also be controlled with an external voltage source for tracking. SS/TRACK should not exceed the voltage on VDD.
4	2	FB	Inverting input to the error amplifier to set the output voltage and compensate the voltage mode control loop.
5	3	COMP	Output of the internal error amplifier. The COMP voltage is compared to an internally generated ramp of the PWM comparator to establish the duty cycle command.
6	4	FADJ	Frequency adjust pin. The switching frequency can be set to a predetermined rate by connecting a resistor between FADJ and GND.
7	6	SYNC	Frequency synchronization pin. An external clock signal can be applied to SYNC to set the switching frequency. The SYNC frequency must be greater than the frequency set by the FADJ pin. If the signal is not present, the switching frequency will decrease to the frequency set by the FADJ resistor. SYNC should not exceed the voltage on VDD and should be grounded if not used.
8	5	EN	LM27402 enable pin. Apply a voltage typically higher than 1.17V to EN and the LM27402 will begin to switch if VIN and VDD have exceeded the UVLO voltage. A hysteresis of 100 mV on EN provides noise immunity. EN is internally tied to VDD through a 2 $\mu$ A pullup current source. EN should not exceed the voltage on VDD.
9	8	PGOOD	Power good output flag. PGOOD is connected to the drain of a pulldown FET. The PGOOD pin is typically connected to VDD through a pull-up resistor.
10	7	VIN	Input supply rail. The VIN operating range is 3V to 20V and is connected to the input rail through an RC filter.
11	9	GND	Common ground.
12	10	VDD	Internal sub-regulated 4.5V bias supply. VDD is used to supply the voltage on CBOOT to facilitate high-side FET switching. Connect a 1 $\mu$ F ceramic capacitor from VDD to GND as close as possible to the LM27402. VDD cannot be connected to a separate voltage rail. However, VDD can be connected to VIN to provide increased gate drive only if $V_{IN} \leq 5.5V$ . A 1 $\Omega$ , 1 $\mu$ F input filter can be used for increased noise rejection.
13	11	LG	Low-side N-FET gate drive.
14	12	SW	Switch-node connection and return path for the high-side gate driver.
15	14	HG	High-side N-FET gate drive.
16	13	CBOOT	High-side gate driver supply rail. Connect a ceramic capacitor from CBOOT to SW and a Schottky diode from VDD to CBOOT.
EP	EP	EP	Exposed Pad. The EP must be connected to GND but cannot be used as the primary ground connection. Use multiple vias under this pad for optimal thermal performance.



These devices have limited built-in ESD protection. The leads should be shorted together or the device placed in conductive foam during storage or handling to prevent electrostatic damage to the MOS gates.

### Absolute Maximum Ratings <sup>(1)(2)</sup>

Unless otherwise specified, voltages are from the indicated pins to GND.	
VIN, CS+, CS-, SW	-0.3V to +22V
VDD, PGOOD	-0.3V to +6V
EN, SYNC, SS/TRACK, FADJ, COMP, FB, LG	-0.3V to VDD
CBOOT	-0.3V to +24V
CBOOT to SW	+6V
CS+ to CS-	-2V to +2V
Storage Temperature	-65°C to 150°C
Junction Temperature	150°C
Lead Temperature (Soldering, 10 sec)	260°C
Minimum ESD Rating <sup>(3)</sup>	±2kV

- (1) Absolute Maximum Ratings indicate limits beyond which damage to the device may occur. Operating Ratings indicate conditions for which the device is intended to be functional, but do not ensure specific performance limits. For ensured specifications and test conditions, see the Electrical Characteristics.
- (2) If Military/Aerospace specified devices are required, please contact the Texas Instruments Sales Office/Distributors for availability and specifications.
- (3) The human body model is a 100 pF capacitor discharged through a 1.5 kΩ resistor to each pin.

### Operating Ratings <sup>(1)</sup>

Input Voltage Range <sup>(2)</sup>	
VIN	+3.0V to +20V
VIN (VDD = VIN)	+3.0V to +5.5V
VDD to GND	+2.2V to +5.5V
SS/TRACK, SYNC, EN	0V to V <sub>VDD</sub>
PGOOD	0V to +5.5V
Junction Temperature	-40°C to + 125°C
θ <sub>JA</sub> (WQFN-16) <sup>(3)</sup>	40°C/W
θ <sub>JA</sub> (HTSSOP-16) <sup>(3)</sup>	40°C/W

- (1) Absolute Maximum Ratings indicate limits beyond which damage to the device may occur. Operating Ratings indicate conditions for which the device is intended to be functional, but do not ensure specific performance limits. For ensured specifications and test conditions, see the Electrical Characteristics.
- (2) VDD is the output of an internal linear regulator. Under normal operating conditions where VIN is greater than 5.5V, VDD must not be connected to any external voltage source. In an application where VIN is between 3.0V and 5.5V, it is recommended to connect VDD to VIN. In order to have better noise rejection under these conditions, a 1Ω and 1μF RC input filter may be used.
- (3) Tested on a four layer JEDEC board. Four vias are provided under the WQFN exposed pad and nine vias are provided under the HTSSOP exposed pad.

## Electrical Characteristics System Parameters

Unless otherwise stated, the following conditions apply:  $V_{IN} = 12V$ . Limits in standard type are for  $T_J = 25^\circ C$  only, limits in **bold face type** apply over the junction temperature ( $T_J$ ) range of  $-40^\circ C$  to  $+125^\circ C$ . Minimum and maximum limits are specified through test, design, or statistical correlation. Typical values represent the most likely parametric norm at  $T_J = 25^\circ C$  and are provided for reference purposes only.

Symbol	Parameter	Conditions	Min	Typ	Max	Units
<b>OPERATIONAL SPECIFICATIONS</b>						
$I_Q$	Quiescent Current	$V_{FB} = 0.6V$ (not switching)		4.5	<b>6.0</b>	mA
$I_{QSD}$	Quiescent Current In Shutdown	$V_{EN} = 0V$		25	<b>45</b>	$\mu A$
<b>UVLO</b>						
UVLO	Input Under Voltage Lockout	$V_{VIN}$ Rising, $V_{VDD}$ Rising	<b>2.7</b>	2.9	<b>2.99</b>	V
UVLO <sub>HYS</sub>	UVLO Hysteresis	$V_{VIN}$ Falling, $V_{VDD}$ Falling		300		mV
<b>REFERENCE</b>						
$V_{FB}$	Feedback Voltage		<b>0.594</b>	0.600	<b>0.606</b>	V
$I_{FB}$	Feedback Pin Bias Current	$V_{FB} = 0.65V$	-50	0	50	nA
<b>SWITCHING</b>						
$F_{SW}$	Switching Frequency	$R_{FADJ} = 4.12 k\Omega$	<b>950</b>	1150	<b>1350</b>	kHz
$F_{SW}$	Switching Frequency	$R_{FADJ} = 20 k\Omega$	<b>400</b>	500	<b>600</b>	kHz
$F_{SW}$	Switching Frequency	$R_{FADJ} = 95.3 k\Omega$	<b>175</b>	214	<b>265</b>	kHz
$D_{MAX}$	Maximum Duty Cycle	$F_{SW} = 300 kHz$	<b>93</b>	95		%
$T_{OFF\_MIN}$	Minimum Off Time	$V_{FB} = 0.5V$	<b>125</b>	165	<b>205</b>	ns
<b>VDD SUB-REGULATOR</b>						
$V_{DD}$	Sub-Regulator Output Voltage	$I_{DD} = 25 mA$	<b>4.0</b>	4.5	<b>5.0</b>	V
<b>ERROR AMPLIFIER</b>						
$B_{W-3db}$	Open Loop Bandwidth			2		MHz
$A_{VOL}$	Error Amp DC Gain			50		dB
$V_{SLEW\_RISE}$	Error Amplifier Rising Slew Rate	$V_{FB} = 0.5V$		5		V/ $\mu s$
$V_{SLEW\_FALL}$	Error Amplifier Falling Slew Rate	$V_{FB} = 0.7V$		3		V/ $\mu s$
$I_{SOURCE}$	COMP Source Current	$V_{FB} = 0.5V$	8	12		mA
$I_{SINK}$	COMP Sink Current	$V_{FB} = 0.7V$	4	12		mA
$V_{COMP\_MAX}$	Max COMP Voltage	$V_{FB} = 0.5V$		3.1		V
$V_{COMP\_MIN}$	Min COMP Voltage	$V_{FB} = 0.7V$		0.5		V
<b>OVER CURRENT</b>						
$V_{OFFSET}$	Comparator Voltage Offset		<b>-5</b>	0	<b>5</b>	mV
$I_{CS-}$	Current Limit Offset Current	$V_{CS} = 5V$	<b>9.5</b>	10.0	<b>10.5</b>	$\mu A$
<b>GATE DRIVE</b>						
$R_{DSON1}$	High-Side FET Driver Pull-Up On Resistance	$V_{CBOOT} - V_{SW} = 4.7V$ , $I_{HG} = +100 mA$		1.7		$\Omega$
$R_{DSON2}$	High-Side FET Driver Pull-Down On Resistance	$V_{CBOOT} - V_{SW} = 4.7V$ , $I_{HG} = -100 mA$		1.2		$\Omega$
$R_{DSON3}$	Low-Side FET Driver Pull-Up On Resistance	$V_{VDD} = 4.7V$ , $I_{LG} = +100 mA$		1.7		$\Omega$
$R_{DSON4}$	Low-Side FET Driver Pull-Down On Resistance	$V_{VDD} = 4.7V$ , $I_{LG} = -100 mA$		1.0		$\Omega$
$T_{DT}$	Deadtime Timeout	$F_{SW} = 500 kHz$		40		ns
<b>SOFT-START</b>						
$I_{SS}$	Soft-Start Source Current	$V_{SS/TRACK} = 0V$	<b>2</b>	3	<b>4</b>	$\mu A$
$R_{SS\_PD}$	Soft-Start Pull-Down Resistance	$V_{SS/TRACK} = 0.6V$		288		$\Omega$
$T_{SS\_INT}$	Internal Soft-Start Time			1.28		ms
<b>POWERGOOD</b>						
$I_{PGS}$	PGOOD Low Sink Current	$V_{PGOOD} = 0.2V$ , $V_{FB} = 0.75V$	<b>60</b>	100		$\mu A$

## Electrical Characteristics System Parameters (continued)

Unless otherwise stated, the following conditions apply:  $V_{IN} = 12V$ . Limits in standard type are for  $T_J = 25^\circ C$  only, limits in **bold face type** apply over the junction temperature ( $T_J$ ) range of  $-40^\circ C$  to  $+125^\circ C$ . Minimum and maximum limits are specified through test, design, or statistical correlation. Typical values represent the most likely parametric norm at  $T_J = 25^\circ C$  and are provided for reference purposes only.

Symbol	Parameter	Conditions	Min	Typ	Max	Units
$I_{PGL}$	PGOOD Leakage Current	$V_{PGOOD} = 5V$		1	10	$\mu A$
$O_{VT}$	Over-Voltage Threshold	$V_{FB}$ Rising	<b>114</b>	117	<b>120</b>	%
$O_{VT\_HYS}$	$O_{VT}$ Hysteresis	$V_{FB}$ Falling		2		%
$U_{VT}$	Under-Voltage Threshold	$V_{FB}$ Rising	<b>91</b>	94	<b>97</b>	%
$U_{VT\_HYS}$	$U_{VT}$ Hysteresis	$V_{FB}$ Falling		3		%
$T_{DEGLITCH}$	Deglintch Time	$V_{PGOOD}$ Rising and Falling		20		$\mu s$
<b>ENABLE</b>						
$V_{EN}$	Enable Logic High Threshold	$V_{EN}$ Rising	<b>1.10</b>	1.17	<b>1.24</b>	V
$V_{EN\_HYS}$	Enable Hysteresis	$V_{EN}$ Falling		100		mV
$I_{EN}$	Enable Pin Pull-Up Current	$V_{EN} = 0V$		2		$\mu A$
<b>FREQUENCY SYNCHRONIZATION</b>						
$V_{LH\_SYNC}$	SYNC Pin Logic High	$V_{VDD} = 4.7V$	<b>2.0</b>			V
$V_{LL\_SYNC}$	SYNC Pin Logic Low	$V_{VDD} = 4.7V$			<b>0.8</b>	V
$SYNC_{FSW\_L}$	Minimum Clock Sync Frequency		<b>200</b>			kHz
$SYNC_{FSW\_H}$	Maximum Clock Sync Frequency				<b>1200</b>	kHz
<b>THERMAL SHUTDOWN</b>						
$T_{SHD}$	Thermal Shutdown	Temperature Rising		165		$^\circ C$
$T_{SHD\_HYS}$	Thermal Shutdown Hysteresis	Temperature Falling		15		$^\circ C$

### Typical Performance Characteristics

Unless otherwise stated, all data sheet curves were recorded using [EXAMPLE CIRCUIT 1](#).  $V_{IN} = 12V$ .

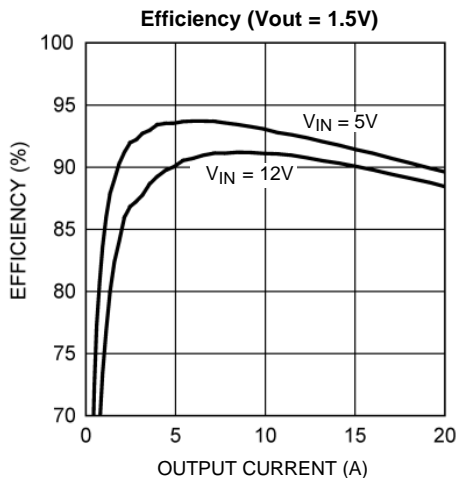

Figure 3.

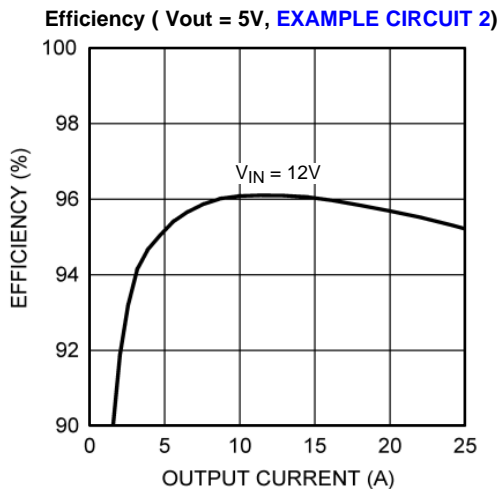

Figure 4.

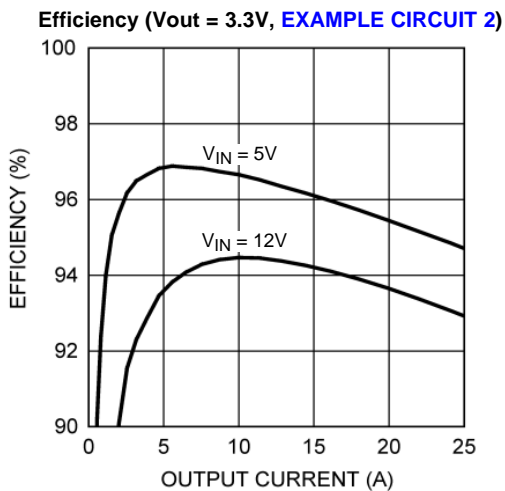

Figure 5.

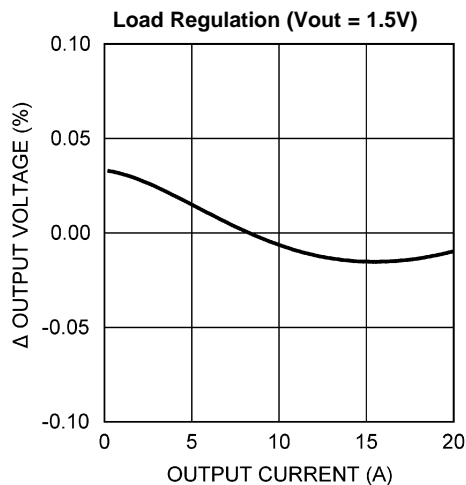

Figure 6.

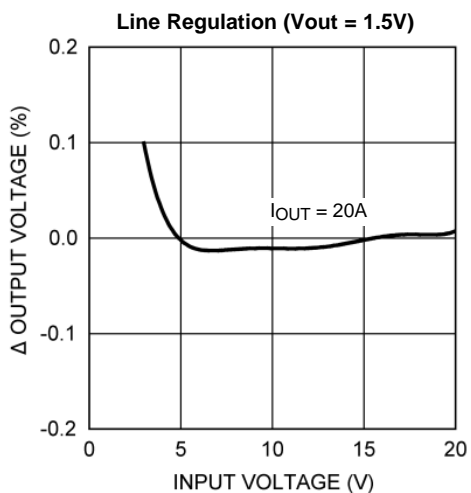

Figure 7.

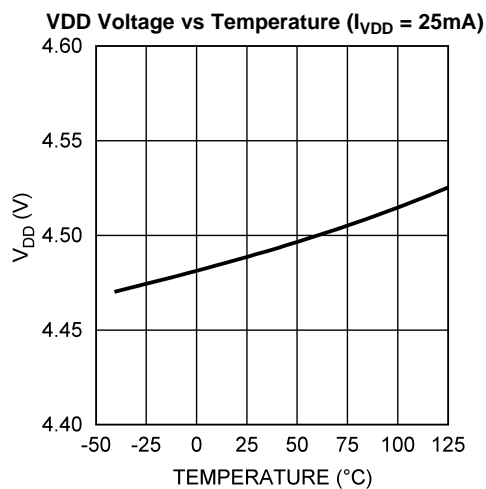

Figure 8.

**Typical Performance Characteristics (continued)**

Unless otherwise stated, all data sheet curves were recorded using [EXAMPLE CIRCUIT 1](#).  $V_{IN} = 12V$ .

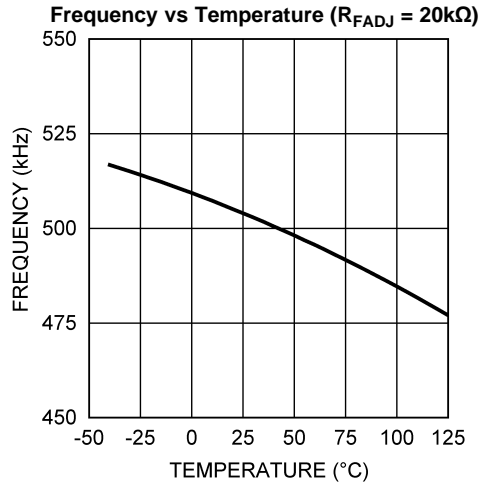

Figure 9.

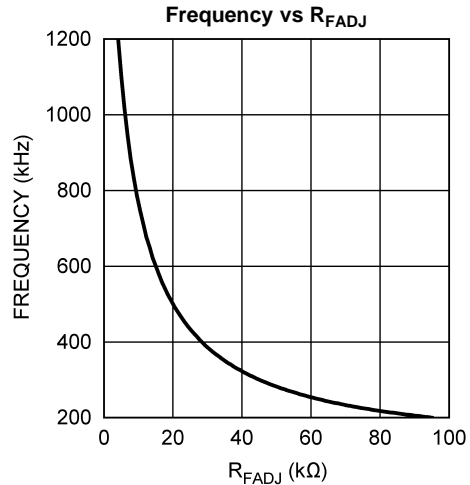

Figure 10.

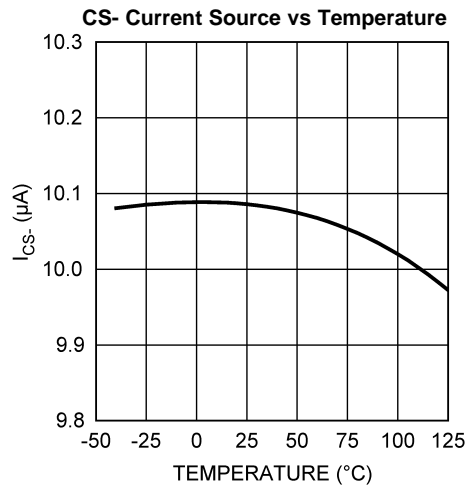

Figure 11.

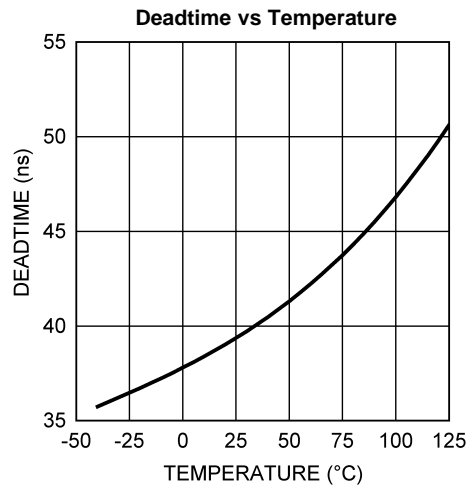

Figure 12.

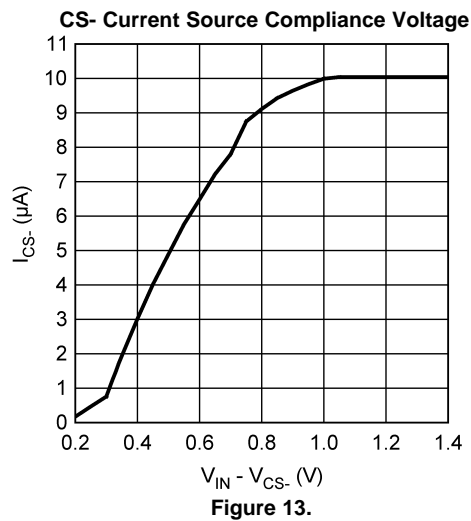
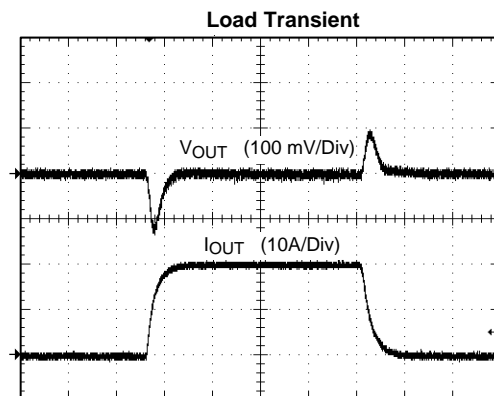

Figure 13.



A. Horizontal Scale: 100 μs/DIV

Figure 14.



### Typical Performance Characteristics (continued)

Unless otherwise stated, all data sheet curves were recorded using [EXAMPLE CIRCUIT 1](#).  $V_{IN} = 12V$ .

Startup Waveforms

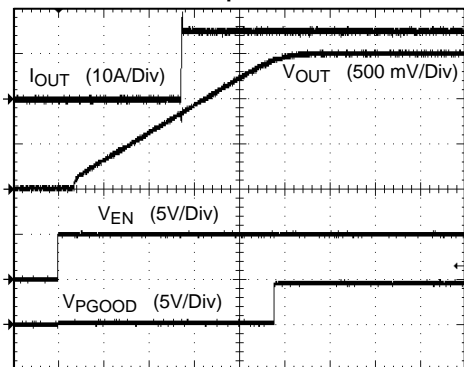

A. Horizontal Scale: 2 ms/DIV

Figure 15.

Pre-Bias Startup Waveforms

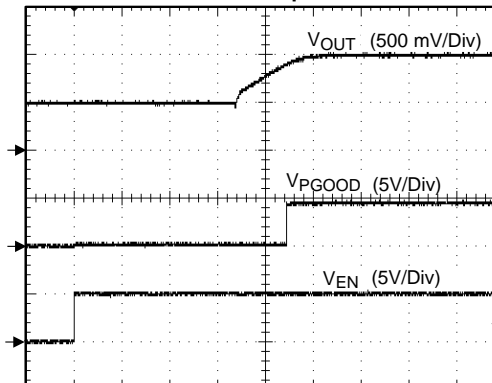

A. Horizontal Scale: 2 ms/DIV

Figure 16.

OCP Hiccup

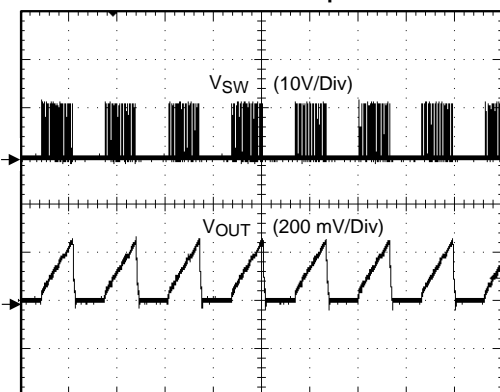

A. Horizontal Scale: 2 ms/DIV

Figure 17.

Sync

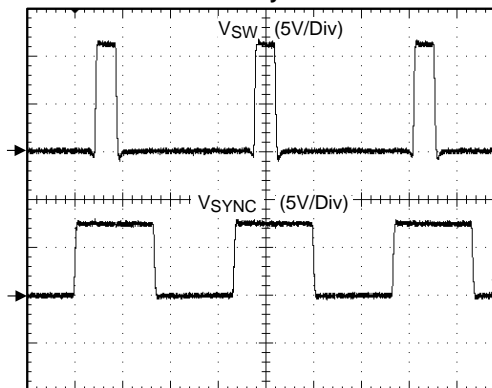

A. Horizontal Scale: 400 ns/DIV

Figure 18.

Tracking

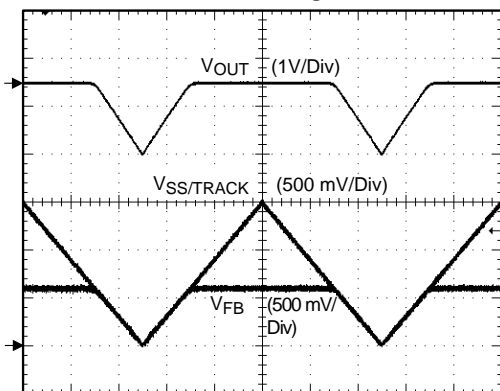

A. Horizontal Scale: 2 ms/DIV

Figure 19.

Shutdown Quiescent Current vs Temperature

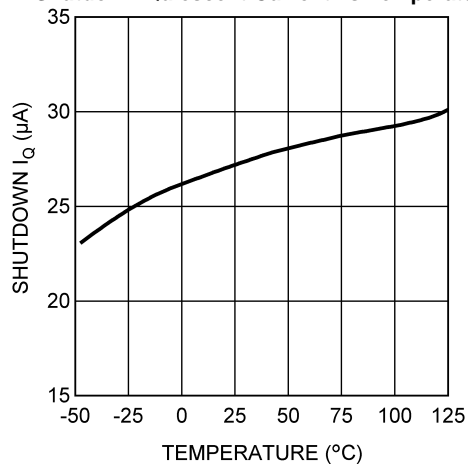

Figure 20.

**Typical Performance Characteristics (continued)**

Unless otherwise stated, all data sheet curves were recorded using [EXAMPLE CIRCUIT 1](#).  $V_{IN} = 12V$ .

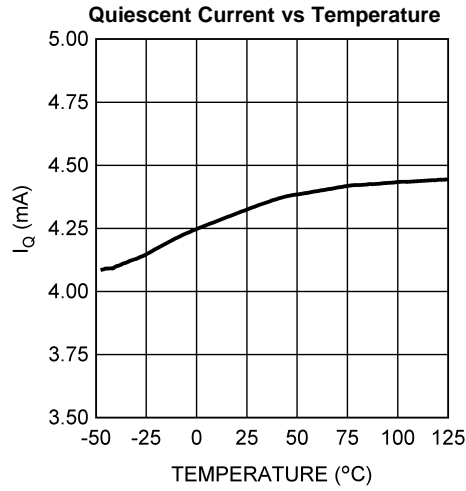

Figure 21.

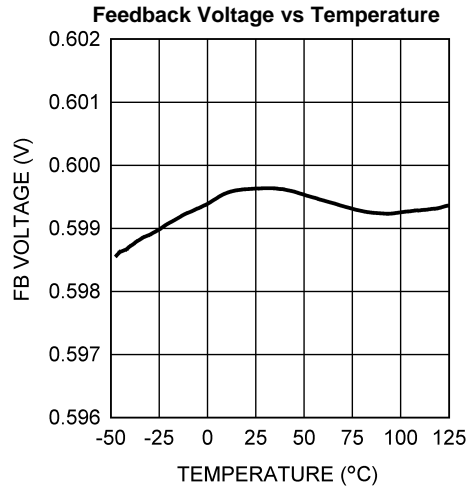
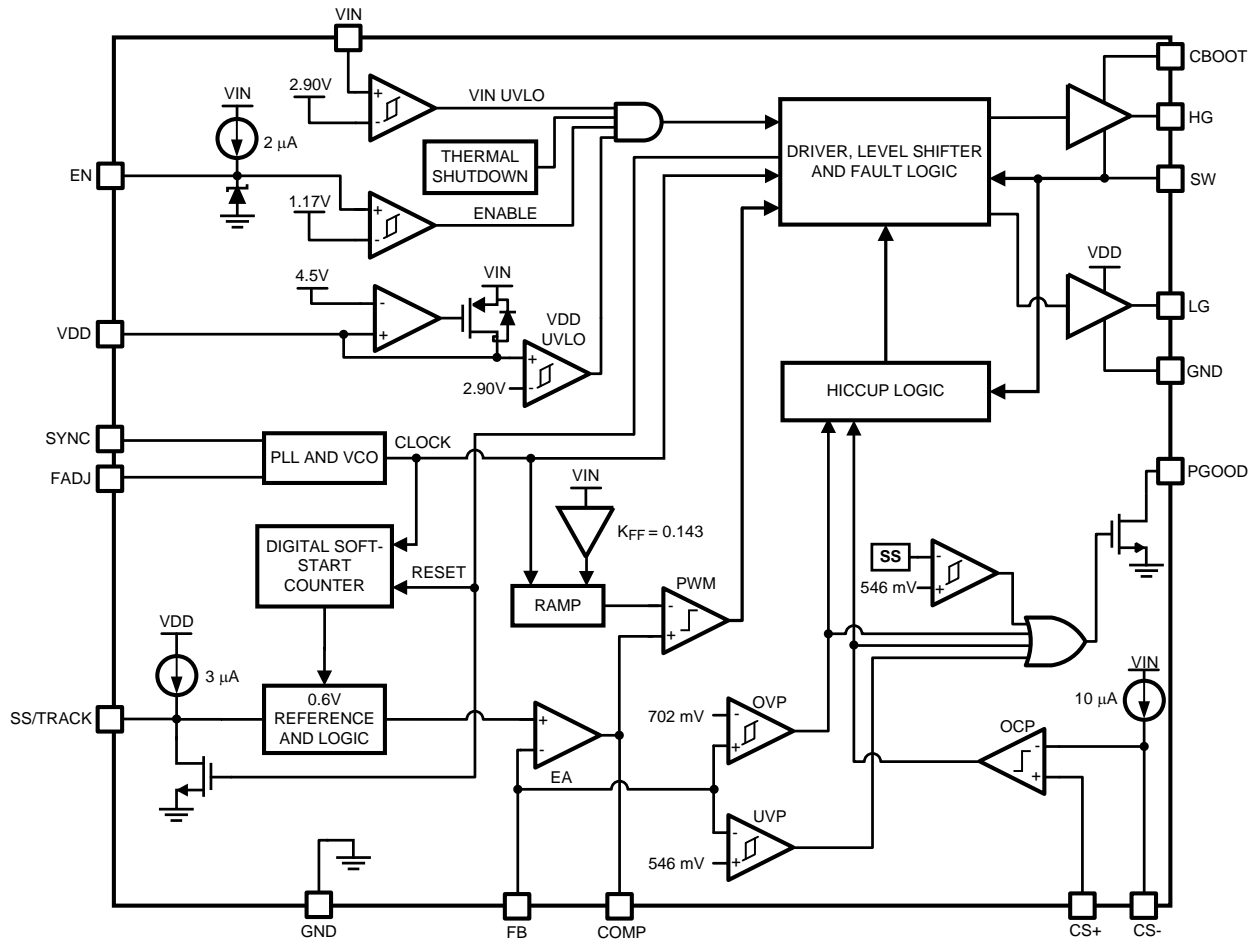

Figure 22.

**BLOCK DIAGRAM**



**THEORY OF OPERATION**

**GENERAL INFORMATION**

The LM27402 is a single-phase synchronous voltage mode DC/DC buck controller. The inductor DCR sense capability and integrated low impedance gate drivers allow the LM27402 to be used in high current, high power density applications. Multiple fault conditions are supported including over-voltage, under-voltage, over-temperature, and over-current. The switching frequency can be adjusted over a wide range either by connecting a clock signal to SYNC pin or a resistor from FADJ to GND. The LM27402 supports pre-biased outputs while maintaining synchronous mode operation. Input voltage feed-forward is incorporated into the control loop to mitigate the effects of input voltage variation.

**UVLO**

An under-voltage lockout is built into the LM27402 which allows the device to only switch if the input voltage (VIN) and the internal sub-regulated voltage (VDD) both exceed 2.9V. A 300mV UVLO hysteresis exists on both VDD and VIN to prevent power on and off anomalies related to input voltage deviations.

## PRECISION ENABLE (EN)

The enable pin of the LM27402 allows the output to be toggled on and off and is a precision analog input. When the EN voltage exceeds 1.17V, the controller will initiate the soft-start sequence as long as the input voltage and sub-regulated voltage have exceeded their UVLO thresholds of 2.9V. The EN pin has an absolute maximum voltage rating of 6.0V and should not exceed the voltage on VDD. There is an internal 2  $\mu$ A pull-up current source connected to the EN pin. If EN is open, the LM27402 will turn on automatically if VIN and VDD exceed 2.9V. If the EN voltage is held below 0.8V, the LM27402 enters a deep shutdown state where the internal bias circuitry is off. The quiescent current is approximately 35  $\mu$ A in deep shutdown. The EN pin has 100mV of hysteresis to reject noise and allow the pin to be resistively coupled to the input voltage or sequenced with other rails.

## SOFT-START AND VOLTAGE TRACKING (SS/TRACK)

When the enable pin has exceeded 1.17V and both VIN and VDD have exceeded their UVLO thresholds, the LM27402 will begin charging the output linearly to the voltage level dictated by the feedback resistor network. The soft-start time is set by connecting a capacitor from SS/TRACK to GND. After EN exceeds 1.17V, an internal 3  $\mu$ A current source begins to linearly charge the soft-start capacitor. Soft-start allows the user to limit inrush currents related to high output capacitance and output slew rate. If a soft-start capacitor is not used, the LM27402 defaults to a 1.28 ms digitally controlled startup time. The SS/TRACK pin can also be used to ratiometrically or coincidentally track an external voltage source. See the [SETTING THE SOFT-START TIME](#) and [TRACKING](#) sections of the design guide for more information.

## PRE-BIAS STARTUP

In certain applications, the output may acquire a pre-bias voltage before the LM27402 is powered on or enabled. Pre-biased conditions are managed by preventing switching until the soft-start (SS/TRACK) voltage exceeds the feedback (FB) voltage. Once  $V_{SS/TRACK}$  has exceeded  $V_{FB}$ , the LM27402 will begin to switch synchronously and regulate the output voltage.

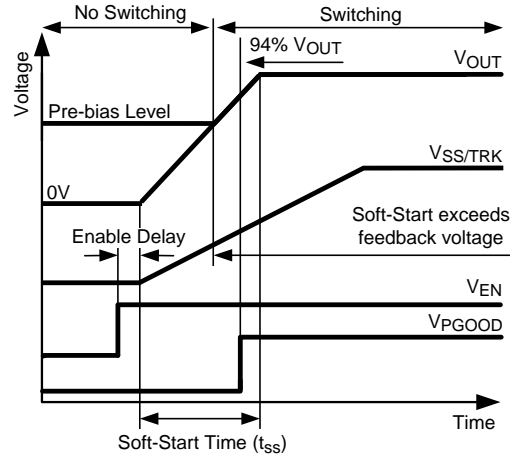

**Figure 23. Pre-Bias Startup**

Prohibiting switching during a pre-biased startup condition prevents the output from forcing parasitic paths to conduct excessive current. The LM27402 will not switch if the output is pre-biased to a voltage higher than the nominally set output voltage.

## CURRENT LIMIT

The LM27402 may enter two states when a current limit event is detected. If a current limit condition has occurred, the high-side FET is immediately turned off until the next switching cycle. This is considered the first current limit state and provides an immediate response to any current limit event. During the first state, an internal counter will begin to record the number of over-current events. The counter is reset if 32 consecutive switching cycles occur with no current limit events detected. If five over-current events are detected within 32

switching cycles, the LM27402 then enters into a hiccup mode state. During hiccup mode, the LM27402 will shutdown for 1.28 ms and then attempt to restart again. When transitioning into hiccup mode, the high-side FET is turned off and the low-side FET is turned on. As the inductor current reaches zero subsequent to the over-current event, the low-side FET is turned off and the switch-node becomes high impedance to prepare for the next startup sequence. The soft-start capacitor is discharged through an internal pull-down FET to reinitialize the startup sequence. To illustrate how the LM27402 behaves during current limit faults, an over-current scenario is illustrated in Figure 24.

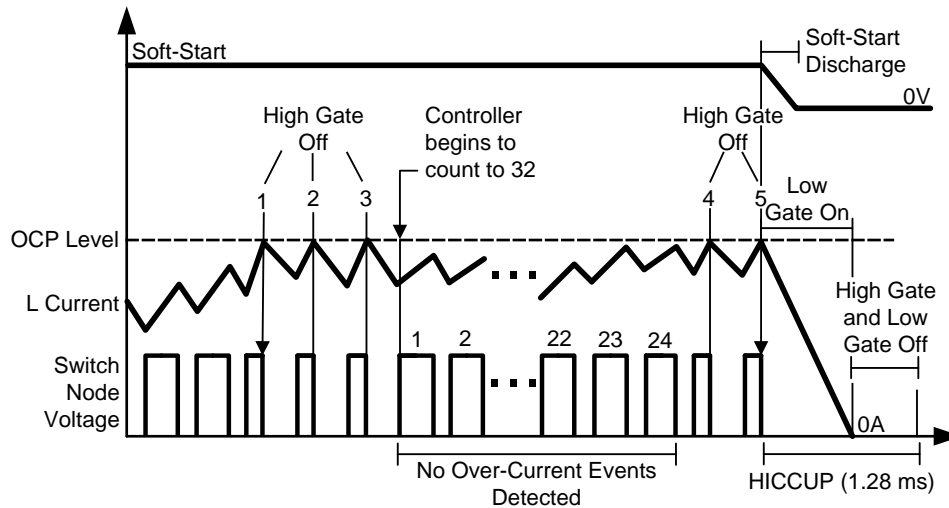

Figure 24. Current Limit Timing Diagram

In the example shown in Figure 24, the LM27402 immediately turns off the high-side FET when an over-current pulse is detected. After the third over-current event is detected, 24 switching cycles occur before the fourth over-current pulse is detected. Since the current limit logic does not count 32 switching cycles between two over-current events, the internal current limit counter is not reset and continues counting until the LM27402 enters hiccup mode. The soft-start capacitor is then discharged to initialize startup and a wait period of 1.28 ms occurs.

### NEGATIVE CURRENT LIMIT

To prevent excess negative current, the LM27402 implements a negative current limit through the low-side FET. Negative current limit is only enabled when an over-voltage event is detected. Should an over-voltage fault occur, the low-side FET will turn off if the SW pin voltage exceeds a positive 100mV during the low-side on time, thereby protecting the powertrain from excessive negative current.

### POWER GOOD

The PGOOD pin of the LM27402 is used to signal when the output is out of regulation or during non-regulated pre-biased conditions. This means that current limit, UVLO, over-voltage threshold, under-voltage threshold, or a non regulated output will cause the PGOOD pin to pull low. To prevent glitches to PGOOD, a 20 μs de-glitch filter is built into the LM27402. Figure 25 illustrates when the PGOOD flag is asserted low.

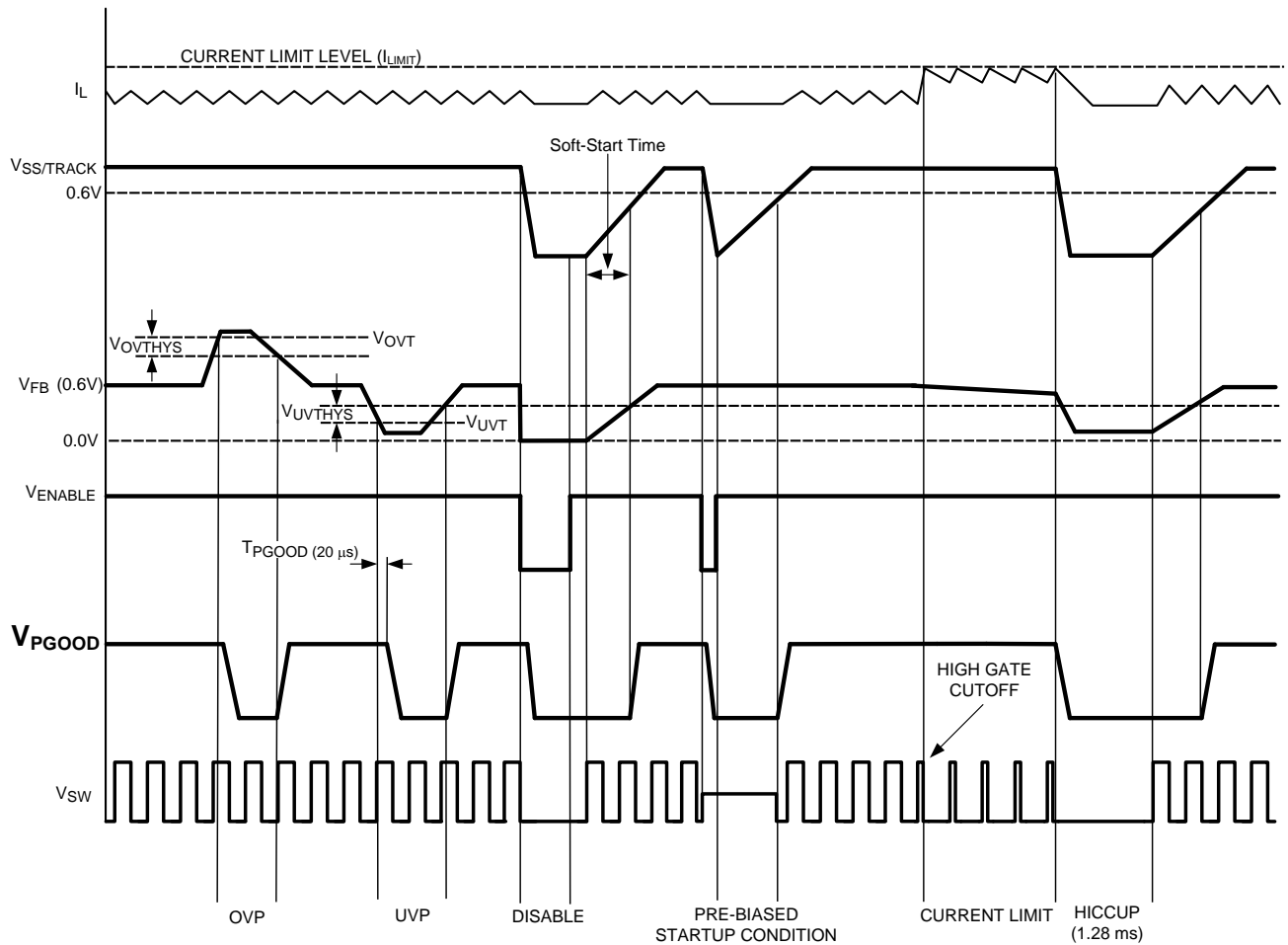

Figure 25. Power Good Behavior

### THERMAL PROTECTION

Internal thermal shutdown is provided to protect the controller in the event that the maximum junction temperature of approximately 165°C has been exceeded. Both the high-side and low-side FETs are turned off during this condition. During a thermal fault condition, PGOOD is held at logic zero.

## DESIGN GUIDE

The Design Guide assists the designer with the steps necessary to select the external components to build a fully functional power supply. As with any DC-DC converter numerous tradeoffs are possible to optimize the design for efficiency, size, or performance. These tradeoffs will be taken into account and highlighted throughout the discussion. To facilitate component selection, the circuit shown in [Figure 26](#) below may be used as a reference. Unless otherwise indicated, all formulae assume units of Amps (A) for current, Farads (F) for capacitance, Henries (H) for inductance and Volts (V) for voltage.

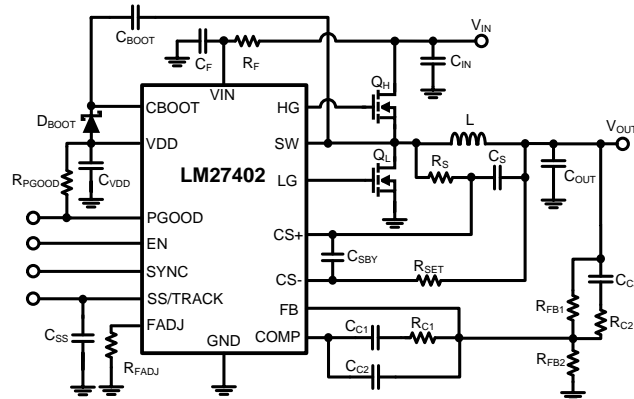

**Figure 26. Typical Application Circuit**

The above schematic shows  $R_F$  and  $C_F$  acting as an RC filter to the input of the LM27402. The filter is used to attenuate voltage ripple that may exist on the input rail particularly during high output currents. The recommended values of  $R_F$  and  $C_F$  are 2.2Ω and 1 μF, respectively. There is a practical limit to the size of  $R_F$  as it can cause a large voltage drop if large operating bias currents are present. The  $V_{IN}$  pin of the LM27402 should not exceed 150 mV difference from the input voltage rail ( $V_{IN}$ ).

The first equation to calculate for any buck converter is duty ratio:

$$D = \frac{V_{OUT}}{V_{IN}} \times \frac{1}{\eta} \quad (1)$$

Due to the resistive powertrain losses, the duty ratio will increase based on the overall efficiency,  $\eta$ . Calculation of  $\eta$  can be found in the [POWER / EFFICIENCY CALCULATIONS](#) section of this datasheet.

### INDUCTOR SELECTION (L)

The inductor value is determined based on the operating frequency, load current, ripple current, and duty ratio. The selected inductor should have a saturation current rating greater than the peak current limit of the LM27402. To optimize the performance, the inductance is typically selected such that the ripple current,  $\Delta I_L$ , is between 20% and 40% of the rated output current. [Figure 27](#) illustrates the switch voltage and inductor ripple current waveforms. Once the nominal input voltage, output voltage, operating frequency, and desired ripple current are known, the minimum inductance value can be calculated by:

$$L_{MIN} = \frac{(V_{IN} - V_{OUT}) \times D}{\Delta I_L \times f_{SW}} \quad (2)$$

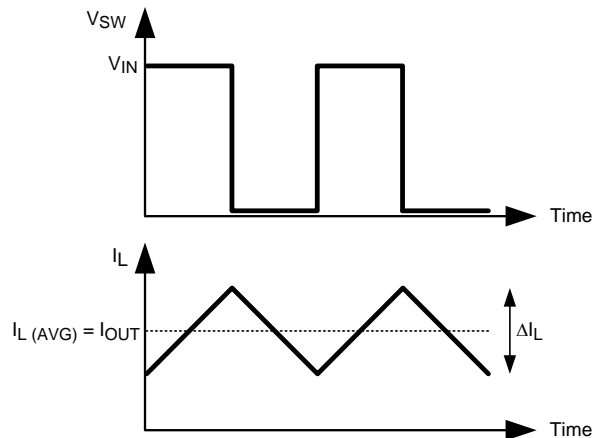

**Figure 27. Switch Voltage and Inductor Current Waveforms**

The peak inductor current at maximum load,  $I_{OUT} + \Delta I_L/2$ , should be kept adequately below the peak current limit setpoint of the device.

### OUTPUT CAPACITOR SELECTION ( $C_{OUT}$ )

The output capacitor,  $C_{OUT}$ , filters the inductor ripple current and provides a source of charge for transient load events. A wide range of output capacitors may be used with the LM27402 that provide excellent performance. The best performance is typically obtained using ceramic, tantalum, or electrolytic type chemistries. Typically, ceramic capacitors provide extremely low ESR to reduce the output ripple voltage and noise spikes, while tantalum and electrolytic capacitors provide a large bulk capacitance in a small size for transient loading events. When selecting the output capacitance value, the two performance characteristics to consider are the output voltage ripple and transient response. The output voltage ripple can be approximated by:

$$\Delta V_{OUT} = \Delta I_L \times \sqrt{R_{ESR}^2 + \left(\frac{1}{8 \times f_{SW} \times C_{OUT}}\right)^2} \quad (3)$$

where  $\Delta V_{OUT}$  (V) is the amount of peak to peak voltage ripple at the power supply output,  $R_{ESR}$  ( $\Omega$ ) is the series resistance of the output capacitor,  $f_{SW}$  (Hz) is the switching frequency, and  $C_{OUT}$  (F) is the output capacitance used in the design. The amount of output ripple that can be tolerated is application specific; however a general recommendation is to keep the output ripple less than 1% of the rated output voltage. Note that ceramic capacitors are sometimes preferred because they have very low ESR; however, depending on package and voltage rating of the capacitor, the value of capacitance can drop significantly with applied voltage and operating temperature.

The output capacitor will affect the output voltage droop during a load transient. The peak output voltage deviation is dependent on many factors such as output capacitance, output capacitor ESR, inductor size, control loop bandwidth, powertrain parasitics, etc. Given sufficient control loop bandwidth, a good approximation of the output voltage deviation is:

$$\Delta V_{TR} = \frac{L \times \Delta I_O^2}{2 \times C_{OUT} \times V_L} + \frac{R_{ESR}^2 \times C_{OUT} \times V_L}{2 \times L} \quad (4)$$

$\Delta V_{TR}$  (V) is the transient output voltage deviation,  $\Delta I_{OUT}$  (A) is the load current step change and  $L$  (H) is the filter inductance.  $V_L$  is the minimum inductor voltage which is duty ratio dependent.

$$V_L = V_{OUT}, \text{ if } D \leq 0.5,$$

$$V_L = V_{IN} - V_{OUT}, \text{ if } D > 0.5$$

For a desired  $\Delta V_{TR}$  (V), a minimum output capacitance can be found by:



$$C_{OUT} \geq \frac{L \times \Delta I_{OUT}^2}{\Delta V_{TR} \times V_L} \times \frac{1}{1 + \sqrt{1 - \left( \frac{R_{ESR} \times \Delta I_{OUT}}{\Delta V_{TR}} \right)^2}} \quad (5)$$

### INPUT CAPACITOR SELECTION (C<sub>IN</sub>)

Input capacitors are necessary to limit the input ripple voltage while supplying much of the switch current during the high-side FET on-time. It is generally recommended to use ceramic capacitors at the input as they provide both a low impedance and a high RMS current rating. It is important to choose a stable dielectric for the ceramic capacitor such as X5R or X7R. A quality dielectric provides better temperature performance and also avoids the DC voltage derating inherent with Y5V capacitors. The input capacitor should be placed as close as possible to the drain of the high-side FET and the source of the low-side FET. Non-ceramic input capacitors should be selected for RMS current rating, minimum ripple voltage, and to provide damping. A good approximation for the required ripple current rating is given by the relationship:

$$I_{CIN\_RMS} \approx I_{OUT} \times \sqrt{D \times (1 - D)} \quad (6)$$

The highest requirement for RMS current rating occurs for D = 0.5. When D = 0.5, the RMS ripple current rating of the input capacitor should be greater than half the output current. Low ESR ceramic capacitors can be placed in parallel with higher valued bulk capacitors to provide optimized input filtering for the regulator.

The input voltage ripple can be calculated using:

$$\Delta V_{IN} = \frac{I_{OUT} \times D \times (1 - D)}{C_{IN} \times f_{SW}} + \left( I_{OUT} + \frac{\Delta I_L}{2} \right) \times R_{ESR\_CIN} \quad (7)$$

The minimum amount of input capacitance as a function of desired input voltage ripple can be calculated using:

$$C_{IN} \geq \frac{I_{OUT} \times D \times (1 - D)}{\left( \Delta V_{IN} - \left( I_{OUT} + \frac{\Delta I_L}{2} \right) \times R_{ESR\_CIN} \right) \times f_{SW}} \quad (8)$$

### USING PRECISION ENABLE

If enable (EN) is not controlled directly, the LM27402 can be pre-programmed to turn on at an input voltage higher than the UVLO voltage. This can be done with an external resistor divider from VIN to EN and EN to GND as shown in [Figure 28](#).

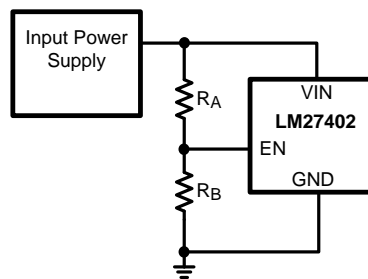

Figure 28. Enable Sequencing

The resistor values of R<sub>A</sub> and R<sub>B</sub> can be relatively sized to allow the EN pin to reach the enable threshold voltage (1.17V) at the appropriate input supply voltage. With the enable current source considered, the equation to solve for R<sub>A</sub> is:

$$R_A = \frac{R_B (V_{IN} - 1.17V)}{1.17V - I_{EN} \times R_B} \quad (9)$$

where  $R_A$  is the resistor from VIN to EN,  $R_B$  is the resistor from EN to GND,  $I_{EN}$  is the internal enable pull-up current ( $2\mu\text{A}$ ) and  $1.17\text{V}$  is the fixed precision enable threshold voltage. Typical values for  $R_B$  range from  $10\text{k}\Omega$  to  $100\text{k}\Omega$ .

### SETTING THE SOFT-START TIME

Adding a soft-start capacitor can reduce inrush currents and provide a monotonic startup. The size of the soft-start capacitor can be calculated by:

$$C_{SS} = \frac{t_{SS} \times I_{SS}}{0.6\text{V}} \quad (10)$$

The size of the  $C_{SS}$  capacitor is influenced by the desired soft-start time  $t_{SS}$  (s), the soft-start current  $I_{SS}$  (A) ( $3\mu\text{A}$ ) and the nominal feedback (FB) voltage level of  $0.6\text{V}$ . If  $V_{VIN}$  and  $V_{VDD}$  are above the UVLO voltage level ( $2.90\text{V}$ ) and EN is above the enable threshold ( $1.17\text{V}$ ), the soft-start sequence will begin. The LM27402 defaults to a minimum startup time of  $1.28\text{ms}$  when no soft-start capacitor is connected. In other words, the LM27402 will not startup faster than  $1.28\text{ms}$ . The soft-start capacitor is discharged when enable is cycled, during UVLO, OTP, or when the LM27402 enters hiccup mode from an over-current event.

There is a delay between EN transitioning above  $1.17\text{V}$  and the beginning of the soft-start sequence. The delay allows the LM27402 to initialize its internal circuitry. Once the output has charged to  $94\%$  of the nominal output voltage and SS/TRACK has exceeded  $564\text{mV}$ , the PGOOD indicator will transition high as illustrated in Figure 29.

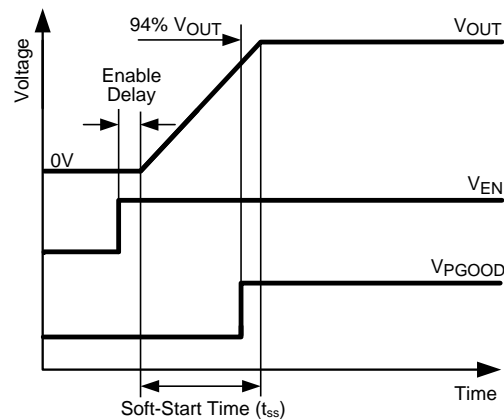

Figure 29. Soft-Start Timing

### TRACKING

The SS/TRACK pin also functions as a tracking pin when external power supply tracking is needed. Tracking is achieved by simply dividing down the external supply voltage with a simple resistor network shown in Figure 30. With the correct resistor divider configuration, the LM27402 can track an external voltage source to obtain a coincident or ratiometric startup behavior.

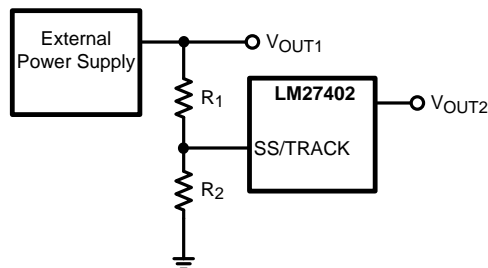

Figure 30. Tracking an External Power Supply

Since the soft-start charging current  $I_{SS}$  is sourced from the SS/TRACK pin, the size of  $R_2$  should be less than 10 k $\Omega$  to minimize errors in the tracking output. Once a value for  $R_2$  is selected, the value for  $R_1$  can be calculated using the appropriate equation in Figure 31 to give the desired startup sequence. Figure 31 shows two common startup sequences; the top waveform shows a coincidental startup while the bottom waveform illustrates a ratiometric startup. A coincidental configuration provides a robust startup sequence for certain applications since it avoids turning on any parasitic conduction paths that may exist between loads. A ratiometric configuration is preferred in applications where both supplies need to be at the final value at the same time.

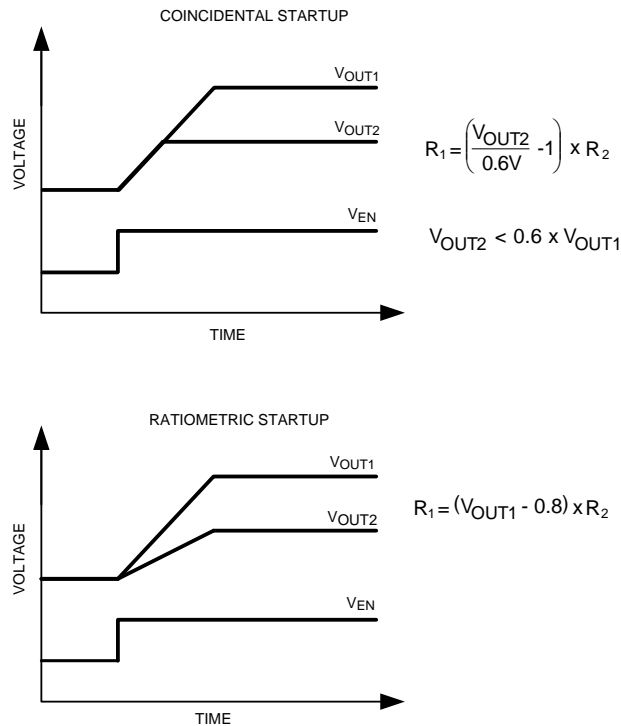

Figure 31. Tracking Startup Sequences

Similar to the soft-start function, the fastest possible startup time is 1.28 ms regardless of the rise time of the tracking voltage. When using the track feature, the final voltage seen by the SS/TRACK pin should exceed 0.8V to provide sufficient overdrive and transient immunity.

### SETTING THE SWITCHING FREQUENCY

There are two options for setting the switching frequency of the LM27402. The frequency can be adjusted by an external resistor from FADJ to GND, or the user can synchronize the LM27402 to an external clock signal through SYNC. The LM27402 will only synchronize to frequencies above the frequency set by the  $R_{FADJ}$  resistor. The clock signal must range from less than 0.8V to greater than 2.0V to ensure proper operation. If the clock signal ceases, the switching frequency will reduce to the frequency set by the FADJ resistor. The frequency range is 200 kHz to 1.2 MHz. The sync-in clock can synchronize a maximum of 400 kHz above the frequency set by the resistor. To find the value of resistance needed for a given frequency use the following equation: ( $f_{SW}$  (kHz),  $R_{FADJ}$  (k $\Omega$ ))

$$R_{FADJ} = \frac{100}{\frac{f_{SW}}{100} - 1} - 5 \tag{11}$$

### SETTING THE CURRENT LIMIT THRESHOLD

The LM27402 exploits the filter inductor DCR (DC resistance) to detect over current events. If desired, the user can employ inductors with low tolerance DCR to increase the accuracy of the current limit threshold. The most common topology for sensing the DCR is shown in Figure 32.

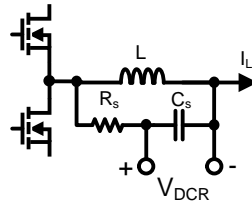
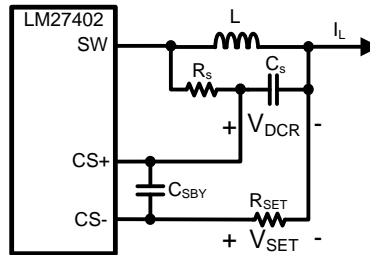

**Figure 32. DCR Sensing Circuit**

The most accurate sensing of voltage across the DCR is achieved by matching the time constant of the  $R_s C_s$  filter with the inductor  $L/R_{DCR}$  time constant. If the time constants are matched, the voltage across the capacitor follows the voltage across the DCR. A typical range of capacitance used in the  $R_s C_s$  network is 100 nF to 1  $\mu$ F. The equation matching the time constants is:

$$R_s C_s = \frac{L}{R_{DCR}} \quad (12)$$

The current limit threshold can be adjusted to any level with a single resistor from the current limit comparator to the output voltage pin. Use the circuit in [Figure 33](#) to set the current limit.



**Figure 33. Setting the Current Limit Level**

Since the voltage across the inductor DCR follows the current through the inductor, the device will trip at the peak of the inductor current. Capacitor  $C_{SBY}$  shown in [Figure 33](#) filters the input to the current sense comparator. A working range for this capacitance is 47 pF to 100 pF. The equation to set the resistor value of  $R_{SET}$  is:

$$R_{SET} = \frac{I_{LIMIT} R_{DCR}}{I_{CS-}} \quad (13)$$

$I_{LIMIT}$  (A) is the desired current limit level,  $R_{DCR}$  ( $\Omega$ ) is the rated DC resistance of the inductor and  $I_{CS-}$  (A) is the 10  $\mu$ A current source flowing out of the CS- pin.

The internal current source  $I_{CS-}$  is powered from the input voltage rail (VIN). The minimum voltage required to power the current source is 1V from VIN to  $V_{OUT}$ . If a condition occurs where  $V_{IN} - V_{OUT} < 1V$ , the LM27402 may prematurely initiate hiccup mode. There are multiple options to avoid this situation. The first option is to enable the LM27402 after the input voltage has risen 1V above the nominal output voltage as seen in [Figure 28](#). The second option is to lower the comparator common mode voltage shown in [Figure 34](#) such that the  $I_{CS-}$  current source has enough headroom voltage.

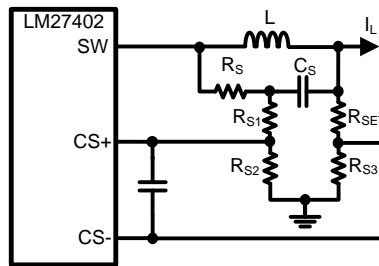

Figure 34. Common Mode Voltage Resistor Divider Network

Please refer to Application Note AN-2060 (literature number [SNVA441](#)) for design guidelines to adjust the common mode voltage of the current sense comparator.

### CONTROL LOOP COMPENSATION

The LM27402 voltage mode control system incorporates input voltage feed-forward to eliminate the input voltage dependence of the PWM gain. Input voltage feed-forward allows the LM27402 to be stable throughout the entire input voltage range and makes it easier for the designer to select the compensation and power components. The following text will describe how to set the output voltage and obtain the open loop transfer function.

During steady state operation, the DC output voltage is set by a feedback resistor network between  $V_{OUT}$ , FB and GND. The FB voltage is nominally  $0.6V \pm 1\%$ . The equation describing the output voltage is:

$$V_{OUT} = \frac{R_{FB1} + R_{FB2}}{R_{FB2}} 0.6V \quad (14)$$

A good starting value for  $R_{FB1}$  is 20 kΩ. If an output voltage of 0.6V is required,  $R_{FB2}$  should not be used.

There are three main blocks of a voltage mode buck switcher that the power supply designer must consider when designing the control system: the powertrain, PWM modulator, and the compensator. A diagram representing the control loop is shown in [Figure 35](#).

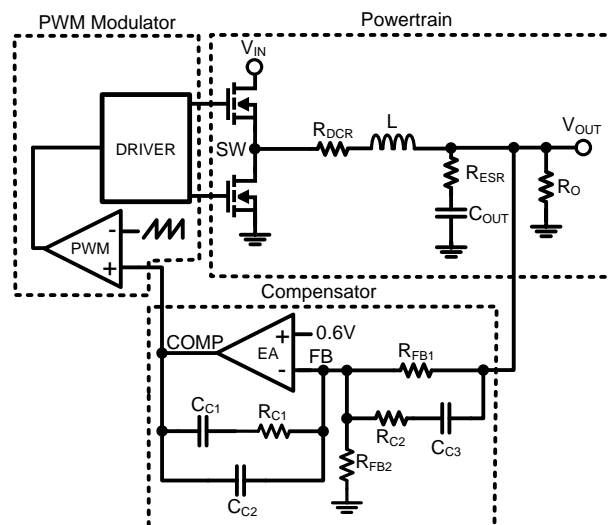

Figure 35. Control Loop Schematic Diagram

The powertrain consists of the filter inductor (L) with DCR ( $R_{DCR}$ ), output capacitor ( $C_{OUT}$ ) with ESR (effective series resistance  $R_{ESR}$ ), and effective load resistance ( $R_O$ ). The error amplifier (EA) regulates the feedback pin (FB) to 0.6V. The passive compensation components around the error amplifier help maintain system stability. Type III compensation is shown in [Figure 35](#). The PWM modulator establishes the duty cycle command by comparing the error amplifier output (COMP) with an internally generated ramp set at the switching frequency.

The modulator gain, powertrain and compensator transfer functions must be taken into consideration when obtaining the total open loop transfer function. The PWM modulator adds a DC gain to the open loop transfer function. In a basic voltage mode system, the PWM gain will vary with input voltage. However the LM27402 internal voltage feed-forward circuitry maintains a constant PWM gain of 7:

$$G_{PWM} = \frac{1}{k_{FF}} = 7 \quad (15)$$

The powertrain transfer function includes the output inductor with DCR, output capacitor with ESR, and load resistance. The inductor and capacitor create two complex poles at a frequency described by:

$$f_{LC} = \frac{1}{2\pi} \sqrt{\frac{R_O + R_{DCR}}{LC_{OUT}(R_O + R_{ESR})}} \quad (16)$$

A left half plane zero is created by the output capacitor ESR located at a frequency described by:

$$f_{ESR} = \frac{1}{2\pi C_{OUT} R_{ESR}} \quad (17)$$

The complete powertrain transfer function is:

$$G_P(s) = \frac{1 + \frac{s}{2\pi f_{ESR}}}{1 + \frac{s}{Q_O 2\pi f_{LC}} + \left(\frac{s}{2\pi f_{LC}}\right)^2} \quad (18)$$

The bode plot of the above transfer function can be seen in [Figure 36](#).

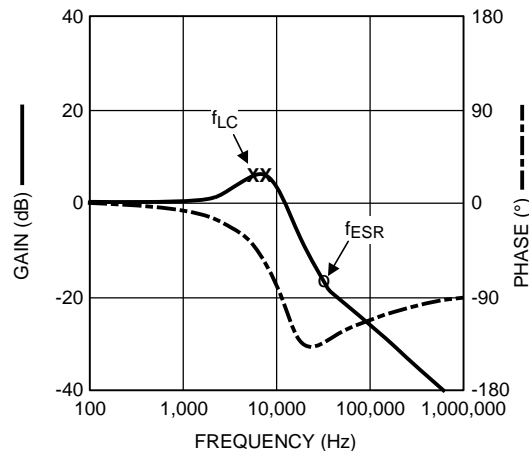

**Figure 36. Powertrain Bode Plot**

The complex poles ( $f_{LC}$ ) created by the filter inductor and output capacitor cause a 180° phase shift as seen in [Figure 36](#). The phase is boosted back up to -90° by virtue of the output capacitor ESR zero. The phase shift caused by the complex poles must be compensated to stabilize the loop response. The compensation network shown around the error amplifier in [Figure 35](#) creates two poles, two zeros and a pole at the origin. Placing these poles and zeros at the correct frequencies will optimize the loop response. The compensator transfer function is:

$$G_{EA}(s) = K_m \frac{\left(\frac{2\pi f_{z1}}{s} + 1\right)\left(\frac{s}{2\pi f_{z2}} + 1\right)}{\left(\frac{s}{2\pi f_{p1}} + 1\right)\left(\frac{s}{2\pi f_{p2}} + 1\right)} \quad (19)$$

The pole located at the origin provides high DC gain to optimize DC load regulation performance. The other two poles and two zeros can be located accordingly to stabilize the voltage mode loop depending on the power stage complex poles and damping characteristic Q. Figure 37 is an illustration of what the error amplifier compensation transfer function will look like.

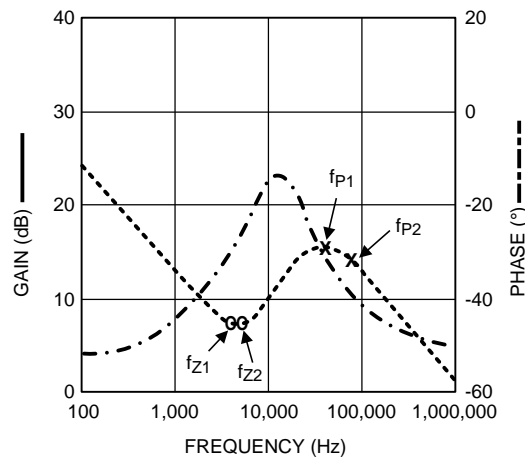

Figure 37. Type III Compensation Network Bode Plot

$K_m$  is the mid-band gain of the compensator and can be estimated by:

$$K_m = \frac{f_C k_{FF}}{f_{LC}} \quad (20)$$

$f_C$  (Hz) is the desired crossover frequency and is usually selected between one tenth and one fifth of the switching frequency ( $f_{SW}$ ). The next set of equations show pole and zero locations expressed in terms of the components in the compensator feedback loop.

$$f_{z1} = \frac{1}{2\pi R_{C1} C_{C1}} \quad f_{z2} = \frac{1}{2\pi (R_{C2} + R_{FB1}) C_{C3}}$$

$$f_{p1} = \frac{1}{2\pi R_{C2} C_{C3}} \quad f_{p2} = \frac{C_{C1} + C_{C2}}{2\pi R_{C1} C_{C1} C_{C2}} \quad K_m = \frac{R_{C1}}{R_{FB1}} \quad (21)$$

Depending on Q, the complex double pole can cause an increase in gain at the LC resonant frequency and a precipitous drop in phase. To compensate for the phase drop, it is common practice to place both compensator zeros created by the type III compensation network at or slightly below the LC double pole frequency. The other two poles should be located beyond this point. One pole is located at the zero caused by the output capacitor ESR and the other pole is placed at half the switching frequency to roll off the higher frequency response.

$$f_{z1} = f_{z2} = f_{LC}$$

$$f_{p1} = f_{ESR}$$

$$f_{p2} = \frac{f_{SW}}{2} \quad (22)$$

Conservative values for the compensation components can be found by using the following equations.

$$R_{C1} = R_{FB1} K_m$$

$$C_{C1} = \frac{1}{2\pi f_{LC} R_{C1}}$$

$$R_{C2} = \frac{R_{FB1} f_{LC}}{f_{ESR} f_{LC}}$$

$$C_{C3} = \frac{1}{2\pi f_{ESR} R_{C2}}$$

$$C_{C2} = \frac{C_{C1}}{\pi f_{SW} R_{C1} C_{C1}^{-1}}$$

(23)

After finding the compensation components it is wise to create a bode plot of the loop response using all three transfer functions. An illustration of the loop response is provided in [Figure 38](#).

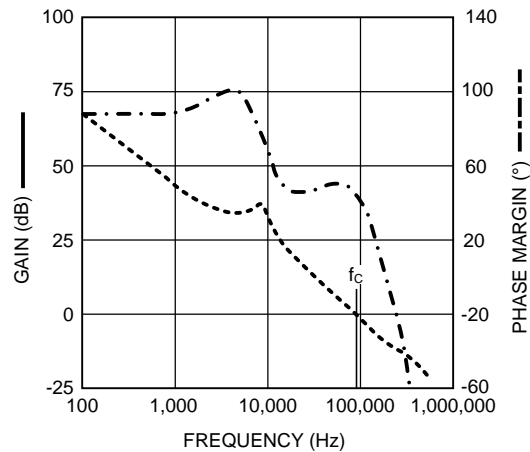

**Figure 38. Loop Response**

It is important to always verify the stability by either observing the load transient response or by using a network analyzer. A phase margin between 45° and 70° is usually desired for voltage mode controlled systems. Excessive phase margin can cause slow system response to load transients and low phase margin may cause an oscillatory load transient response. If the load transient response peak deviation is larger than desired, increasing  $f_c$  and recalculating the compensation components may help but usually at the expense of phase margin.

### MOSFET GATE DRIVE

To drive large MOSFETs with high gate charge, the LM27402 includes low impedance high-side and low-side gate drivers. Low impedance gate drivers allow high current designs by enabling fast transition times and increased efficiency. The high-side gate drive is powered from a charge pump common to the switch-node and the low-side gate is powered by the VDD rail shown in [Figure 39](#).



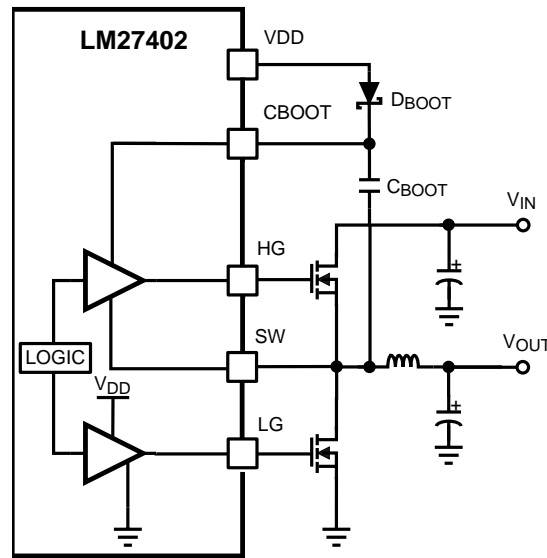

Figure 39. VDD Charge Pump Circuit

The circuit in Figure 39 will effectively supply close to the VDD voltage (4.5V) between the gate and the source of the high-side MOSFET during the on time. It is recommended to use a Schottky diode for D<sub>BOOT</sub> with sufficient reverse standoff voltage and continuous current rating. The average current through this diode is dependent on the gate charge of the high-side FET and the frequency. It can be calculated using the following equation

$$I_{D_{BOOT}} = f_{SW} Q_{GHS} \quad (24)$$

I<sub>D<sub>BOOT</sub></sub> is the average current through the D<sub>BOOT</sub> diode, f<sub>SW</sub> (Hz) is the switching frequency and Q<sub>GHS</sub> (C) is the gate charge of the high-side MOSFET. If the input voltage is below 5.5V, it is recommended to connect VDD to the input supply of the LM27402 through a 1Ω resistor shown in Figure 40. This will increase the gate voltage of both the low-side and high-side FETs.

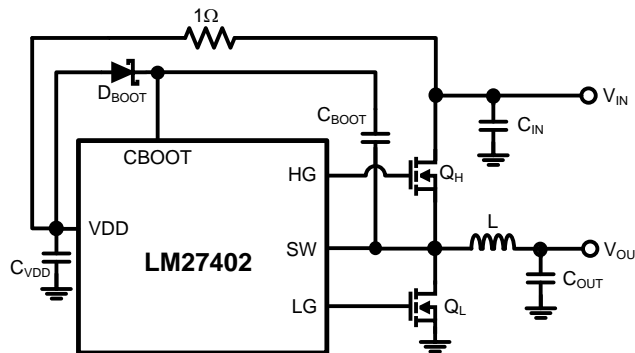

Figure 40. Tie V<sub>DD</sub> to V<sub>IN</sub> when V<sub>IN</sub> ≤ 5.5V

## POWER / EFFICIENCY CALCULATIONS

The overall efficiency of a buck regulator is simply the ratio of output power to input power. Accurately predicting the overall efficiency can be tedious and depends on many variables. Although power losses can be found in almost every component of a buck regulator, the following sections present equations detailing components with the highest relative power loss.

## MOSFETS

Selecting the correct MOSFET for a design is important to the overall operation of the circuit. If inappropriate FETs are selected for the application, it can result in poor efficiency, high temperature issues, shoot-through and other impairments. It is important to calculate the power dissipation for each MOSFET at the maximum output current and make sure the maximum allowable power dissipation is not exceeded. MOSFET datasheets should also specify a junction-to-ambient thermal resistance ( $\theta_{JA}$ ) so the temperature rise can be estimated from this specification.

Both high-side and low-side FETs contribute significant loss to the system relative to the other components. The high-side FET contributes transition switching losses, conduction losses and gate charge losses. The low-side FET also contributes conduction and gate charge losses, but the FET body diode voltage drop during deadtime and reverse recovery loss must also be considered. The transition losses for the low-side FET are small and usually ignored.

### High-Side MOSFET

The next set of equations can be used to calculate the losses associated with the high-side FET.

$$\begin{aligned}
 P_{\text{CND\_HS}} &\approx I_{\text{OUT}}^2 \times R_{\text{DS(ON)\_HS}} \times D \times 1.3 \\
 P_{\text{SW\_HS}} &= \frac{V_{\text{IN}} \times I_{\text{OUT}} \times f_{\text{SW}} \times (t_r + t_f)}{2} \\
 P_{\text{TOT\_HS}} &= P_{\text{CND\_HS}} + P_{\text{SW\_HS}}
 \end{aligned} \tag{25}$$

$P_{\text{CND\_HS}}$  is the conduction loss of the high-side FET during the D cycle when current is flowing through the FET on-resistance. A self heating coefficient of 1.3 is included in this equation to approximate the effects of the  $R_{\text{DS(ON)}}$  temperature coefficient.  $R_{\text{DS(ON)\_HS}}$  ( $\Omega$ ) is the drain to source resistance,  $I_{\text{OUT}}$  (A) is the output current and D is the duty ratio.  $P_{\text{SW\_HS}}$  is the switching power loss during the high-side FET transition time.  $V_{\text{IN}}$  (V) is the input voltage,  $f_{\text{SW}}$  (Hz) is the switching frequency, and  $t_r$  and  $t_f$  (s) are the rise and fall times of the switch-node voltage respectively.  $P_{\text{TOT\_HS}}$  is the total power dissipation of the high-side FET.

The gate charge of the high-side MOSFET can greatly affect the turn-on transition time and therefore efficiency. Furthermore, it is wise to consider the ratio of switching loss to conduction loss associated with the high-side FET. If the duty ratio is small and the input voltage is high, it may be beneficial to tradeoff  $Q_G$  for higher  $R_{\text{DS(ON)}}$  to avoid high switching losses relative to conduction losses. If the duty ratio is large and the input voltage is low, then a lower  $R_{\text{DS(ON)}}$  FET in tandem with a higher  $Q_G$  may result in less power dissipation.

### Low-Side MOSFET

The next set of equations can be used to calculate the losses due to the low-side FET.

$$\begin{aligned}
 P_{\text{CND\_LS}} &\approx I_{\text{OUT}}^2 \times R_{\text{DS(ON)\_LS}} \times (1-D) \times 1.3 \\
 P_D &= T_{\text{deadtime}} \times f_{\text{SW}} \times I_{\text{OUT}} \times V_{\text{FD}} \\
 P_{\text{RR}} &= Q_{\text{RR}} \times f_{\text{SW}} \times V_{\text{IN}} \\
 P_{\text{TOT\_LS}} &= P_{\text{CND\_LS}} + P_D + P_{\text{RR}}
 \end{aligned} \tag{26}$$

$P_{\text{CND\_LS}}$  is the conduction loss of the low-side FET during the 1-D cycle when current is flowing through the on-resistance of the FET.  $R_{\text{DS(ON)\_LS}}$  ( $\Omega$ ) is the drain to source resistance.

$P_D$  is the deadtime power loss due to the body diode drop of the low-side FET.  $T_{\text{deadtime}}$  (s) is the total deadtime.

$P_{\text{RR}}$  is the reverse recovery charge power loss.  $Q_{\text{RR}}$  (C) is the total reverse recovery charge usually specified in the FET datasheet.  $P_{\text{TOT\_LS}}$  is the total power dissipation of the low-side FET.

### Gate Charge Loss

A finite amount of gate charge is required in order to switch the high-side and low-side FETs. This gate charge is continuously charging the FETs during every switching cycle and appears as a constant current flowing into the controller from the input supply. The next equation describes the power loss due to the gate charge.

$$P_{\text{QG}} = V_{\text{IN}} \times (Q_{\text{GHS}} + Q_{\text{GLS}}) \times f_{\text{SW}} \tag{27}$$

$P_{QG}$  is the total gate charge power loss,  $Q_{GHS}$  (C) and  $Q_{GLS}$  (C) are the high-side and low-side FET gate charges respectively, and can be found in the FET datasheets,  $V_{IN}$  (V) is the input voltage, and  $f_{SW}$  (Hz) is the switching frequency.

### **Input and Output Capacitor ESR Losses**

Both the input and output capacitors are subject to steady state AC current and must be taken into consideration when calculating power losses. The next equation shown is the input capacitor ESR power loss.

$$P_{IN\_CAP} = I_{CIN\_RMS}^2 \times R_{ESR\_CIN} \quad (28)$$

The input capacitor power loss equation includes the effective series resistance or  $R_{ESR\_IN}$  ( $\Omega$ ) of the input capacitor. The power loss due to the ESR of the output capacitor is:

$$P_{OUT\_CAP} = \frac{\Delta I_L}{\sqrt{2}} \times R_{ESR} \quad (29)$$

The output capacitor power loss equation includes the peak to peak inductor current,  $\Delta I_L$  (A), and the effective series resistance or  $R_{ESR}$  ( $\Omega$ ) of the output capacitor.

### **Inductor Losses**

The losses due to the inductor are caused primarily by the DCR. The next equation calculates the inductor DCR power loss.

$$P_{DCR} = I_{RMS}^2 \times R_{DCR} \times 1.2 \quad (30)$$

$P_{DCR}$  is the total power loss of the Inductor. A self heating coefficient of 1.2 is included in this equation to approximate the effects of the copper temperature coefficient approximately equal to 3900ppm/°C.  $R_{DCR}$  ( $\Omega$ ) is the inductor DC resistance.

### **Controller Losses**

The controller loss remains constant and contributes to a very small loss of power. The quiescent current is the main factor in terms of power loss attributed to the controller and it remains constant at 4 mA. The quiescent current power loss equation is:

$$P_{IQ} = V_{IN} \times I_Q \quad (31)$$

The controller  $I_Q$  power loss equation includes the  $I_Q$  current (4 mA) and input voltage  $V_{IN}$  (V).

It is also important to calculate the power dissipated in the controller itself due to the gate charge current flowing from  $V_{IN}$  to the output of the LDO (VDD). The gate charge current essentially passes through a resistance dropping the input voltage  $V_{IN}$  to the LDO voltage (4.5V). This can cause the controller to operate at an elevated temperature since it must dissipate the power of the LDO pass device. The next equation calculates the power dissipated by the internal LDO of the controller.

$$P_{LDO} = (V_{VIN} - 4.5) \times (Q_{GLS} + Q_{GHS}) \times f_{SW} \quad (32)$$

$P_{LDO}$  is the power dissipated in the LDO,  $Q_{GHS}$  (C) and  $Q_{GLS}$  are the high-side and low-side FET gate charges, respectively, and can be found in the FET datasheets.

### **Overall Efficiency**

After calculating the losses, the efficiency can then be calculated using:

$$\eta \text{ (\%)} = \frac{P_{OUT}}{P_{OUT} + P_{LOSS}} \times 100$$

$$P_{LOSS} = P_{TOT\_HS} + P_{TOT\_LS} + P_{QG} + P_{DCR} + P_{IN\_CAP} + P_{OUT\_CAP} + P_{IQ}$$

$$P_{OUT} = V_{OUT} \times I_{OUT} \quad (33)$$

## PCB LAYOUT CONSIDERATIONS

After selecting the correct components, PCB layout is another crucial step in optimizing a buck regulator. The layout must be able to handle large DC and AC currents, minimize switch-node noise, and spread heat. The following layout guidelines and tips will help increase the chances of a successful design and should be taken seriously during the layout process.

### Input and Output Capacitor Layout

A buck regulator is a switching converter with switched currents and voltages. The high  $di/dt$  and  $dv/dt$  nature of buck switching calls for careful layout of decoupling capacitors. The next figure shows the switching currents for the D and 1-D intervals of a buck regulator.

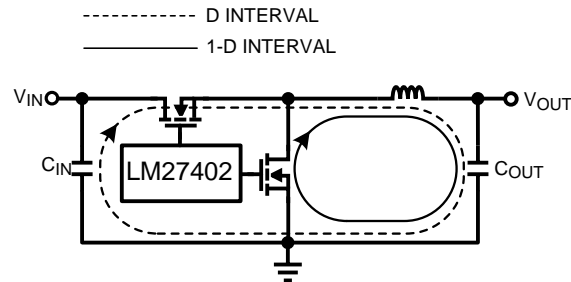

Figure 41. Power Flow

During the high-side FET on time, the AC component of the input current is supplied by the input capacitor. Due to the high  $di/dt$  nature of this current, it is essential that the input capacitor is closely coupled to the drain of the high-side FET to minimize any parasitic inductance. The output capacitor return and input capacitor return should also be closely coupled to minimize parasitic ground inductance. During the low-side FET on time, current flows from ground through the low-side FET and to the output capacitor through the inductor. It is essential the input capacitor is also closely coupled with the low-side FET source.

### MOSFET Layout

With FETs acting as switches in a switching regulator, good layout is essential. Current is constantly transitioning from the high-side FET to the low-side FET so it is essential to place the source of the high-side FET next to the drain of the low-side FET and the switch-node side of the inductor. This will minimize any parasitic inductance between the switch-node and the FETs which can cause switch-node ringing. The FETs can become very hot due to internal power dissipation. Using vias to connect the drain of the FETs to other layers may help spread the heat. The switch-node copper area should not be so small that the low-side FET will not be able to spread its heat.

As seen in the [POWER / EFFICIENCY CALCULATIONS](#) section, the rise times of the FETs can significantly affect the efficiency. Therefore, it is good layout practice to maintain the shortest path from the LG/HG gate pins to the pins of the low-side/high-side FETs to minimize the parasitic inductance. The high-side gate trace should be coupled with the switch-node trace since the internal high-side gate drive is connect between CBOOT and SW. The low-side FET gate trace should be coupled with ground return since the internal low-side gate driver is powered between VDD and ground. A good trace width is around 0.015 inches to support the high transient currents. During switching transition, it is common to see peak transient currents of 1 - 2A flowing through gate traces so minimizing the parasitic inductance is crucial to fast and efficient switching.

### Noise

Because of the high energy switching characteristic of the switching regulator, it is good practice to separate noise generating circuitry from noise sensitive circuitry. For a buck regulator, this means separating the switch-node from the feedback circuitry. This can be achieved by distance or can be shielded on the back side of the board through an internal copper ground plane.

Reducing the noise in the DCR sense circuitry is imperative to realize accurate effective over-current response. Separation of this circuitry from the switch-node and gate drivers will reduce the amount of switching noise pickup at the input of the current limit comparator. Running the DCR sense traces in parallel as a differential pair can significantly reduce the effect of any system noise (including switch-node pickup) at the input of the current limit comparator.

The SW pin of the LM27402 receives signals directly from the switch-node of the regulator to collect switching information. This is an unimpeded noise path that may cause erratic switching behavior if excessive noise is injected from the switch-node. If needed, a snubber can be used to limit the dv/dt of the signal effectively reducing the noise into the switch-node sense pin.

### ***Controller Layout***

Proper layout practices of the controller can help ensure proper operation. Locating the input decoupling capacitor ( $C_F$ ), as close as possible to the VDD capacitor ( $C_{VDD}$ ) with the LM27402 GND will help increase noise immunity.

**EXAMPLE CIRCUIT 1**

Figure 42. 5V - 12V  $V_{IN}$  to 1.5V  $V_{OUT}$ , 20A  $I_{OUT}$ , fsw = 300 kHz

**Bill of Materials**

Designator	Type	Parameters	Part Number	Qty	Manufacturer
U1	Synchronous Buck Controller		LM27402	1	TI
$C_{BOOT}$	Capacitor	0.22 $\mu$ F, Ceramic, X7R, 25V, 10%	GRM188R71E224KA88D	1	Murata
$C_{C1}$	Capacitor	3900 pF, Ceramic, X7R, 50V, 10%	GRM188R71H392KA01D	1	Murata
$C_{C2}$	Capacitor	150 pF, Ceramic, C0G, 50V, 5%	GRM1885C1H151JA01D	1	Murata
$C_{C3}$	Capacitor	820 pF, Ceramic, C0G, 50V, 5%	GRM1885C1H821JA01D	1	Murata
$C_{VDD}$	Capacitor	1 $\mu$ F, Ceramic, X5R, 25V, 10%	GRM188R61E105KA12D	1	Murata
$C_F$	Capacitor	1 $\mu$ F, Ceramic, X5R, 25V, 10%	GRM188R61E105KA12D	1	Murata
$C_{IN}$	Capacitor	22 $\mu$ F, Ceramic, X5R, 25V, 10%	GRM32ER61E226KE15L	5	Murata
$C_{OUT}$	Capacitor	100 $\mu$ F, Ceramic, X5R, 6.3V, 20%	C1210C107M9PACTU	4	Kemet
$C_S$	Capacitor	0.22 $\mu$ F, Ceramic, X7R, 25V, 10%	GRM188R71E224KA88D	1	Murata
$C_{SS}$	Capacitor	47000 pF, Ceramic, X7R, 16V, 10%	GRM188R71C473KA01D	1	Murata
$C_{SBY}$	Capacitor	100 pF, Ceramic, C0G, 50V, 5%	GRM1885C1H101JA01D	1	Murata
$D_{BOOT}$	Diode	Schottky Diode, Average I = 100 mA, Max Surge I = 750 mA	CMOSH-3	1	Central Semi
$D_{SW}$	Diode	Schottky Diode, Average I = 3A, Max Surge I = 80A	CMSH3-40M	1	Central Semi
$L_{OUT}$	Inductor	.68 $\mu$ H, 2.34 m $\Omega$	IHLP5050CEERR68M06	1	Vishay
$Q_L$	N-CH MOSFET	30V, 60A, 43.5 nC, $R_{DS(ON)}$ @ 4.5V = 1.85 m $\Omega$	Si7192DP	1	Vishay
$Q_H$	N-CH MOSFET	25V, 40A, 13 nC, $R_{DS(ON)}$ @ 4.5V = 6.2 m $\Omega$	SiR436DP	1	Vishay
$R_{C1}$	Resistor	8.06 k $\Omega$ , 1%, 0.1W	CRCW06038k06FKEA	1	Vishay
$R_{C2}$	Resistor	261 $\Omega$ , 1%, 0.1W	CRCW0603261RFKEA	1	Vishay
$R_{FADJ}$	Resistor	45.3 k $\Omega$ , 1%, 0.1W	CRCW060345K3FKEA	1	Vishay
$R_{FB1}$	Resistor	20.0 k $\Omega$ , 1%, 0.1W	CRCW060320K0FKEA	1	Vishay
$R_{FB2}$	Resistor	20.0 k $\Omega$ , 1%, 0.1W	CRCW060320K0FKEA	1	Vishay
$R_F$	Resistor	2.2 $\Omega$ , 5%, 0.1W	CRCW06032R20JNEA	1	Vishay
$R_{PGD}$	Resistor	51.1 k $\Omega$ , 5%, 0.1W	CRCW060351K1JNEA	1	Vishay
$R_S$	Resistor	1.3 k $\Omega$ , 1%, 0.1W	CRCW06031K30FKEA	1	Vishay
$R_{SET}$	Resistor	6.34 k $\Omega$ , 1%, 0.1W	CRCW06036K34FKEA	1	Vishay

**EXAMPLE CIRCUIT 2**

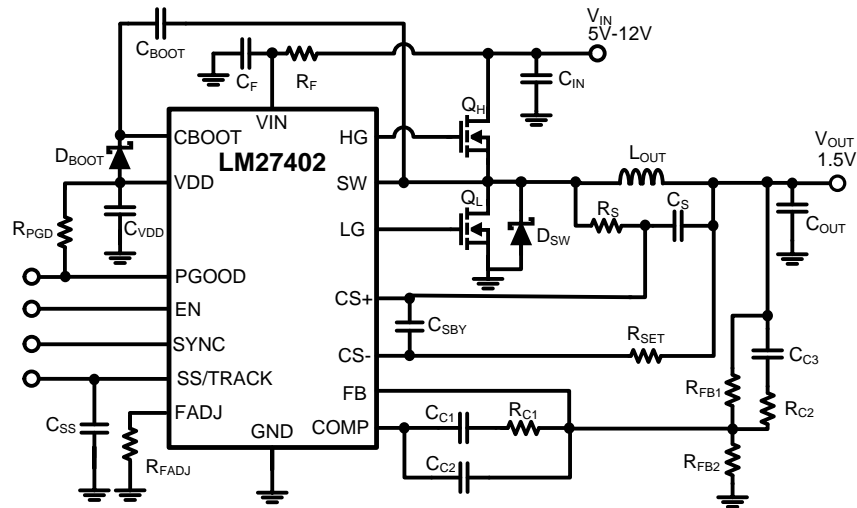
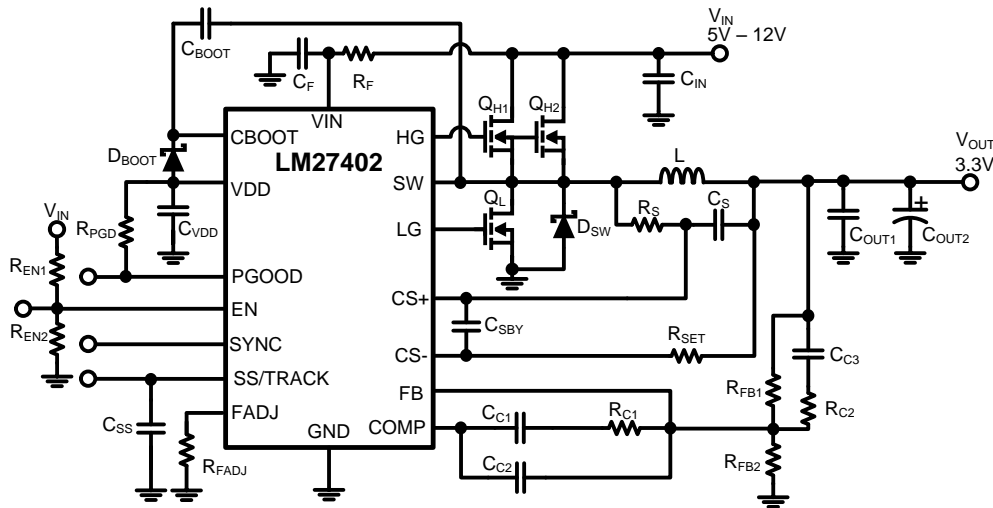
**Figure 43. 5V - 12V  $V_{IN}$  to 3.3V  $V_{OUT}$ , 25A  $I_{OUT}$ , fsw = 300 kHz**
**Bill Of Materials**

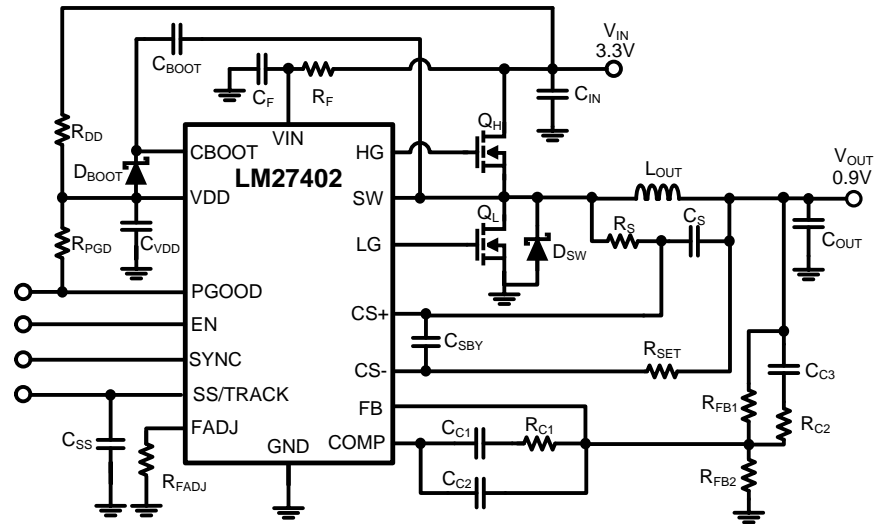
Designator	Type	Parameters	Part Number	Qty	Manufacturer
U1	Synchronous Buck Controller		LM27402	1	TI
$C_{BOOT}$	Capacitor	0.22 $\mu$ F, Ceramic, X7R, 25V, 10%	GRM188R71E224KA88D	1	Murata
$C_{C1}$	Capacitor	1200 pF, Ceramic, COG, 50V, 5%	GRM1885C1H122JA01D	1	Murata
$C_{C2}$	Capacitor	56 pF, Ceramic, COG, 50V, 5%	GRM1885C1H560JA01D	1	Murata
$C_{C3}$	Capacitor	820 pF, Ceramic, COG, 50V, 5%	GRM1885C1H821JA01D	1	Murata
$C_{VDD}$	Capacitor	1 $\mu$ F, Ceramic, X5R, 25V, 10%	GRM188R61E105KA12D	1	Murata
$C_F$	Capacitor	1 $\mu$ F, Ceramic, X5R, 25V, 10%	GRM188R61E105KA12D	1	Murata
$C_{IN}$	Capacitor	22 $\mu$ F, Ceramic, X5R, 25V, 10%	GRM32ER61E226KE15L	5	Murata
$C_{OUT1}$	Capacitor	100 $\mu$ F, Ceramic, X5R, 6.3V, 20%	C1210C107M9PACTU	1	Kemet
$C_{OUT2}$	Capacitor	330 $\mu$ F, POSCAP, 6.3V, 20%	6TPE1330MIL	1	Sanyo
$C_S$	Capacitor	0.22 $\mu$ F, Ceramic, X7R, 25V, 10%	GRM188R71E224KA88D	1	Murata
$C_{SS}$	Capacitor	47000 pF, Ceramic, X7R, 16V, 10%	GRM188R71E473KA01D	1	Murata
$C_{SBY}$	Capacitor	100 pF, Ceramic, COG, 50V, 5%	GRM1885C1H101JA01D	1	Murata
$D_{BOOT}$	Diode	Schottky Diode, Average I = 100 mA, Max Surge I = 750 mA	CMOSH-3	1	Central Semi
$D_{SW}$	Diode	Schottky Diode, Average I = 3A, Max Surge I = 80A	CMSH3-40M	1	Central Semi
$L_{OUT}$	Inductor	1 $\mu$ H, 0.9 m $\Omega$	SER2010-102ML	1	Coilcraft
$Q_L$	N-CH MOSFET	30V, 60A, 43.5 nC, $R_{DS(ON)}$ @ 4.5V = 1.85 m $\Omega$	Si7192DP	1	Vishay
$Q_{H(1,2)}$	N-CH MOSFET	25V, 50A, 20 nC, $R_{DS(ON)}$ @ 4.5V = 3.4 m $\Omega$	SiR892DP	1	Vishay
$R_{C1}$	Resistor	18.7 k $\Omega$ , 1%, 0.1W	CRCW060318K7FKEA	1	Vishay
$R_{C2}$	Resistor	4.75 k $\Omega$ , 1%, 0.1W	CRCW06034K75FKEA	1	Vishay
$R_{FADJ}$	Resistor	45.3 k $\Omega$ , 1%, 0.1W	CRCW060345K3FKEA	1	Vishay
$R_{FB1}$	Resistor	20.0 k $\Omega$ , 1%, 0.1W	CRCW060320K0FKEA	1	Vishay
$R_{FB2}$	Resistor	4.42 k $\Omega$ , 1%, 0.1W	CRCW06034K42FKEA	1	Vishay
$R_F$	Resistor	2.2 $\Omega$ , 5%, 0.1W	CRCW06032R20JNEA	1	Vishay
$R_{PGND}$	Resistor	51.1 k $\Omega$ , 5%, 0.1W	CRCW060351K1JNEA	1	Vishay
$R_S$	Resistor	4.12 k $\Omega$ , 1%, 0.1W	CRCW06034K12FKEA	1	Vishay
$R_{SET}$	Resistor	4.53 k $\Omega$ , 1%, 0.1W	CRCW06034K53FKEA	1	Vishay

**EXAMPLE CIRCUIT 3**

**Figure 44. 3.3V  $V_{IN}$  to 0.9V  $V_{OUT}$ , 20A  $I_{OUT}$ , fsw = 500 kHz**

**Bill Of Materials**

Designator	Type	Parameters	Part Number	Qty	Manufacturer
U1	Synchronous Buck Controller		LM27402	1	TI
$C_{BOOT}$	Capacitor	0.22 $\mu$ F, Ceramic, X7R, 25V, 10%	GRM188R71E224KA88D	1	Murata
$C_{C1}$	Capacitor	820 pF, Ceramic, COG, 50V, 5%	GRM1885C1H821JA01D	1	Murata
$C_{C2}$	Capacitor	68 pF, Ceramic, COG, 50V, 5%	GRM1885C1H680JA01D	1	Murata
$C_{C3}$	Capacitor	390 pF, Ceramic, COG, 50V, 5%	GRM1885C1H391JA01D	1	Murata
$C_{VDD}$	Capacitor	1 $\mu$ F, Ceramic, X5R, 25V, 10%	GRM188R61E105KA12D	1	Murata
$C_F$	Capacitor	1 $\mu$ F, Ceramic, X5R, 25V, 10%	GRM188R61E105KA12D	1	Murata
$C_{IN}$	Capacitor	22 $\mu$ F, Ceramic, X5R, 25V, 10%	C2012X5R0J226M	5	TDK
$C_{OUT}$	Capacitor	100 $\mu$ F, Ceramic, X5R, 6.3V, 20%	JMK316BJ107ML	3	Taiyo Yuden
$C_S$	Capacitor	0.22 $\mu$ F, Ceramic, X7R, 25V, 10%	GRM188R71E224KA88D	1	Murata
$C_{SS}$	Capacitor	22000 pF, Ceramic, X7R, 16V, 10%	GRM188R71E223KA01D	1	Murata
$C_{SBY}$	Capacitor	68 pF, Ceramic, COG, 50V, 5%	GRM1885C1H680JA01D	1	Murata
$D_{BOOT}$	Diode	Schottky Diode, Average I = 100 mA, Max Surge I = 750 mA	CMOSH-3	1	Central Semi
$D_{SW}$	Diode	Schottky Diode, Average I = 3A, Max Surge I = 80A	CMSH3-40M	1	Central Semi
$L_{OUT}$	Inductor	0.33 $\mu$ H, 1.4 m $\Omega$	RL-8250-1.4-R33M	1	Renco
$Q_L$	N-CH MOSFET	20V, 100A, 64 nC, $R_{DS(ON)}$ @ 4.5V = 1.6 m $\Omega$	BSC019N02KS	1	Infineon
$Q_H$	N-CH MOSFET	20V, 100A, 40 nC, $R_{DS(ON)}$ @ 4.5V = 2.1 m $\Omega$	BSC026N02KS	1	Infineon
$R_{C1}$	Resistor	10.0 k $\Omega$ , 1%, 0.1W	CRCW060310K0FKEA	1	Vishay
$R_{C2}$	Resistor	150 $\Omega$ , 1%, 0.1W	CRCW0603150RFKEA	1	Vishay
$R_{DD}$	Resistor	1 $\Omega$ , 5%, 0.1W	CRCW06031R00JNEA	1	Vishay
$R_{FADJ}$	Resistor	20.0 k $\Omega$ , 1%, 0.1W	CRCW060320K0FKEA	1	Vishay
$R_{FB1}$	Resistor	20.0 k $\Omega$ , 1%, 0.1W	CRCW060320K0FKEA	1	Vishay
$R_{FB2}$	Resistor	40.2 k $\Omega$ , 1%, 0.1W	CRCW060340K2FKEA	1	Vishay
$R_F$	Resistor	2.2 $\Omega$ , 5%, 0.1W	CRCW06032R20JNEA	1	Vishay
$R_{PGD}$	Resistor	51.1 k $\Omega$ , 5%, 0.1W	CRCW060351K1JNEA	1	Vishay
$R_S$	Resistor	1.07 k $\Omega$ , 1%, 0.1W	CRCW06031K07FKEA	1	Vishay
$R_{SET}$	Resistor	5.11 k $\Omega$ , 1%, 0.1W	CRCW06035K11FKEA	1	Vishay



---

**REVISION HISTORY**

<b>Changes from Revision H (March 2013) to Revision I</b>	<b>Page</b>
<hr/> <ul style="list-style-type: none"><li>• Changed layout of National Data Sheet to TI format .....</li></ul>	<hr/> <a href="#">32</a>

## PACKAGING INFORMATION

Orderable Device	Status (1)	Package Type	Package Drawing	Pins	Package Qty	Eco Plan (2)	Lead/Ball Finish	MSL Peak Temp (3)	Op Temp (°C)	Top-Side Markings (4)	Samples
LM27402MH/NOPB	ACTIVE	HTSSOP	PWP	16	92	Green (RoHS & no Sb/Br)	CU SN	Level-1-260C-UNLIM		L27402 MH	<a href="#">Samples</a>
LM27402MHX/NOPB	ACTIVE	HTSSOP	PWP	16	2500	Green (RoHS & no Sb/Br)	CU SN	Level-1-260C-UNLIM		L27402 MH	<a href="#">Samples</a>
LM27402SQ/NOPB	ACTIVE	WQFN	RUM	16	1000	Green (RoHS & no Sb/Br)	CU SN	Level-1-260C-UNLIM	-40 to 125	27402S	<a href="#">Samples</a>
LM27402SQX/NOPB	ACTIVE	WQFN	RUM	16	4500	Green (RoHS & no Sb/Br)	CU SN	Level-1-260C-UNLIM	-40 to 125	27402S	<a href="#">Samples</a>

(1) The marketing status values are defined as follows:

**ACTIVE:** Product device recommended for new designs.

**LIFEBUY:** TI has announced that the device will be discontinued, and a lifetime-buy period is in effect.

**NRND:** Not recommended for new designs. Device is in production to support existing customers, but TI does not recommend using this part in a new design.

**PREVIEW:** Device has been announced but is not in production. Samples may or may not be available.

**OBSOLETE:** TI has discontinued the production of the device.

(2) Eco Plan - The planned eco-friendly classification: Pb-Free (RoHS), Pb-Free (RoHS Exempt), or Green (RoHS & no Sb/Br) - please check <http://www.ti.com/productcontent> for the latest availability information and additional product content details.

**TBD:** The Pb-Free/Green conversion plan has not been defined.

**Pb-Free (RoHS):** TI's terms "Lead-Free" or "Pb-Free" mean semiconductor products that are compatible with the current RoHS requirements for all 6 substances, including the requirement that lead not exceed 0.1% by weight in homogeneous materials. Where designed to be soldered at high temperatures, TI Pb-Free products are suitable for use in specified lead-free processes.

**Pb-Free (RoHS Exempt):** This component has a RoHS exemption for either 1) lead-based flip-chip solder bumps used between the die and package, or 2) lead-based die adhesive used between the die and leadframe. The component is otherwise considered Pb-Free (RoHS compatible) as defined above.

**Green (RoHS & no Sb/Br):** TI defines "Green" to mean Pb-Free (RoHS compatible), and free of Bromine (Br) and Antimony (Sb) based flame retardants (Br or Sb do not exceed 0.1% by weight in homogeneous material)

(3) MSL, Peak Temp. -- The Moisture Sensitivity Level rating according to the JEDEC industry standard classifications, and peak solder temperature.

(4) Multiple Top-Side Markings will be inside parentheses. Only one Top-Side Marking contained in parentheses and separated by a "~" will appear on a device. If a line is indented then it is a continuation of the previous line and the two combined represent the entire Top-Side Marking for that device.

**Important Information and Disclaimer:** The information provided on this page represents TI's knowledge and belief as of the date that it is provided. TI bases its knowledge and belief on information provided by third parties, and makes no representation or warranty as to the accuracy of such information. Efforts are underway to better integrate information from third parties. TI has taken and continues to take reasonable steps to provide representative and accurate information but may not have conducted destructive testing or chemical analysis on incoming materials and chemicals. TI and TI suppliers consider certain information to be proprietary, and thus CAS numbers and other limited information may not be available for release.

In no event shall TI's liability arising out of such information exceed the total purchase price of the TI part(s) at issue in this document sold by TI to Customer on an annual basis.



**TAPE AND REEL INFORMATION**

**QUADRANT ASSIGNMENTS FOR PIN 1 ORIENTATION IN TAPE**

\*All dimensions are nominal

Device	Package Type	Package Drawing	Pins	SPQ	Reel Diameter (mm)	Reel Width W1 (mm)	A0 (mm)	B0 (mm)	K0 (mm)	P1 (mm)	W (mm)	Pin1 Quadrant
LM27402MHX/NOPB	HTSSOP	PWP	16	2500	330.0	12.4	6.95	8.3	1.6	8.0	12.0	Q1
LM27402SQ/NOPB	WQFN	RUM	16	1000	178.0	12.4	4.3	4.3	1.3	8.0	12.0	Q1
LM27402SQX/NOPB	WQFN	RUM	16	4500	330.0	12.4	4.3	4.3	1.3	8.0	12.0	Q1

**TAPE AND REEL BOX DIMENSIONS**

\*All dimensions are nominal

Device	Package Type	Package Drawing	Pins	SPQ	Length (mm)	Width (mm)	Height (mm)
LM27402MHX/NOPB	HTSSOP	PWP	16	2500	367.0	367.0	35.0
LM27402SQ/NOPB	WQFN	RUM	16	1000	210.0	185.0	35.0
LM27402SQX/NOPB	WQFN	RUM	16	4500	367.0	367.0	35.0

PWP0016A

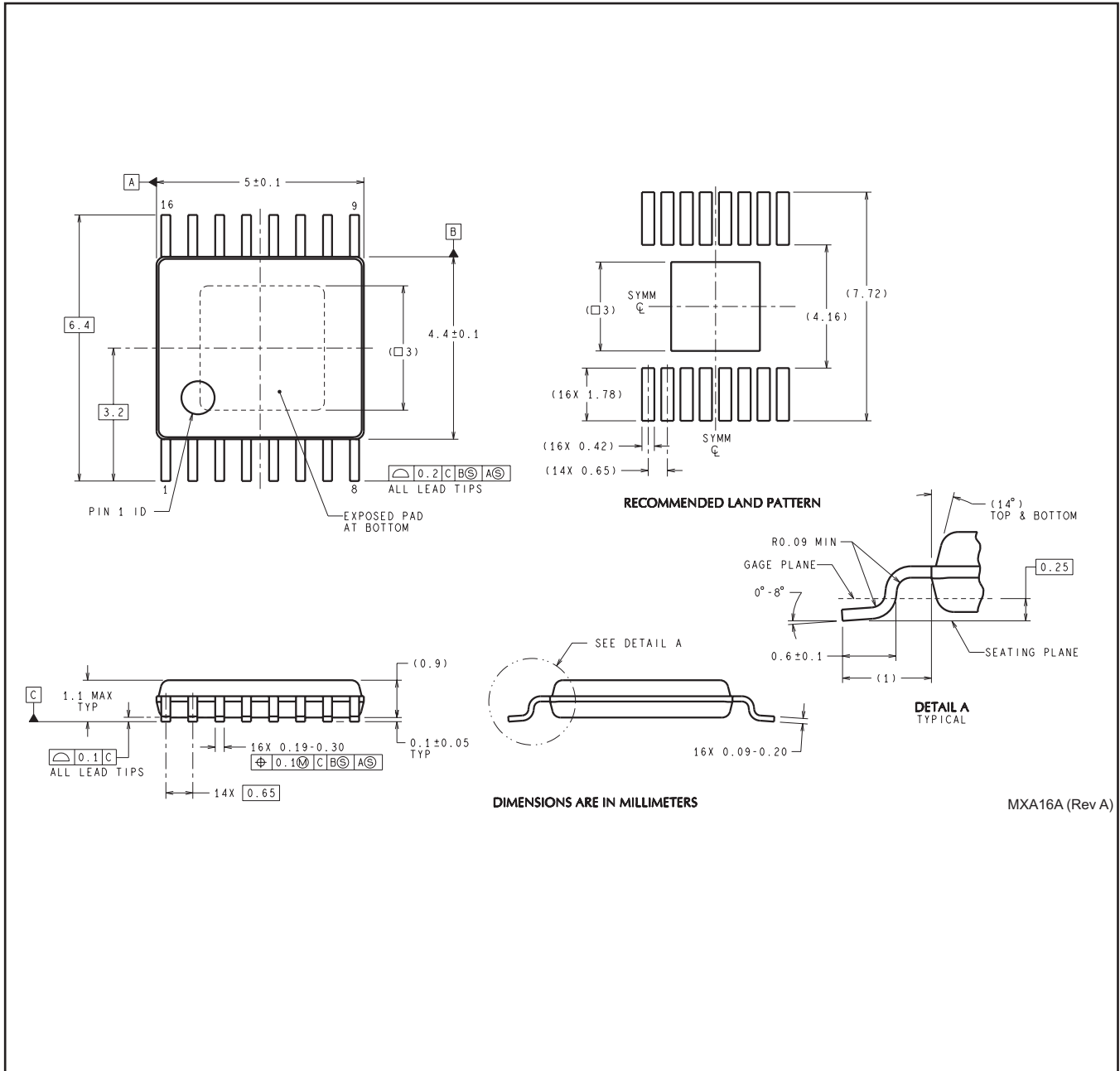

DIMENSIONS ARE IN MILLIMETERS

MXA16A (Rev A)

RUM0016A

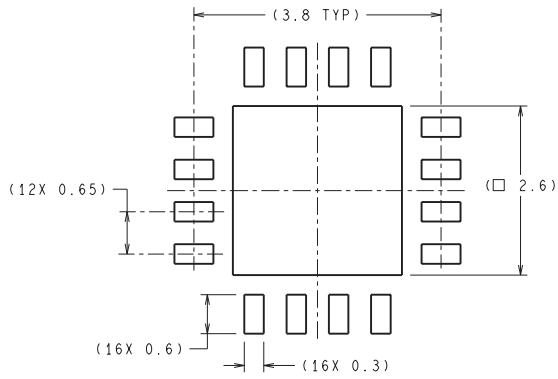

RECOMMENDED LAND PATTERN

DIMENSIONS ARE IN MILLIMETERS  
DIMENSIONS IN ( ) FOR REFERENCE ONLY

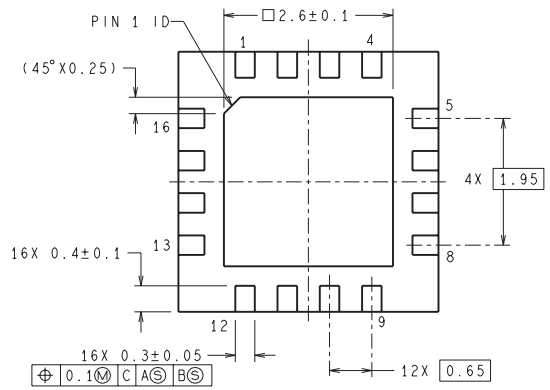
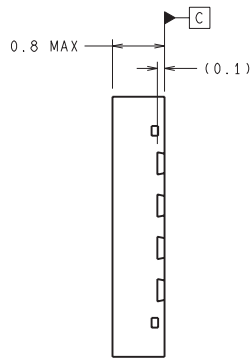
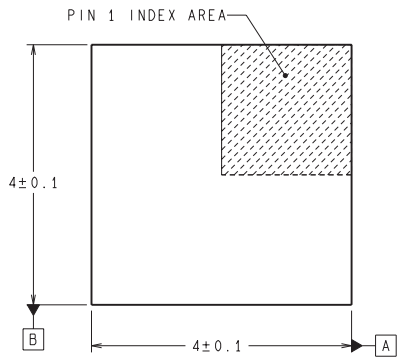
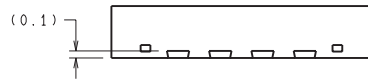

SQB16A (Rev A)

## IMPORTANT NOTICE

Texas Instruments Incorporated and its subsidiaries (TI) reserve the right to make corrections, enhancements, improvements and other changes to its semiconductor products and services per JESD46, latest issue, and to discontinue any product or service per JESD48, latest issue. Buyers should obtain the latest relevant information before placing orders and should verify that such information is current and complete. All semiconductor products (also referred to herein as "components") are sold subject to TI's terms and conditions of sale supplied at the time of order acknowledgment.

TI warrants performance of its components to the specifications applicable at the time of sale, in accordance with the warranty in TI's terms and conditions of sale of semiconductor products. Testing and other quality control techniques are used to the extent TI deems necessary to support this warranty. Except where mandated by applicable law, testing of all parameters of each component is not necessarily performed.

TI assumes no liability for applications assistance or the design of Buyers' products. Buyers are responsible for their products and applications using TI components. To minimize the risks associated with Buyers' products and applications, Buyers should provide adequate design and operating safeguards.

TI does not warrant or represent that any license, either express or implied, is granted under any patent right, copyright, mask work right, or other intellectual property right relating to any combination, machine, or process in which TI components or services are used. Information published by TI regarding third-party products or services does not constitute a license to use such products or services or a warranty or endorsement thereof. Use of such information may require a license from a third party under the patents or other intellectual property of the third party, or a license from TI under the patents or other intellectual property of TI.

Reproduction of significant portions of TI information in TI data books or data sheets is permissible only if reproduction is without alteration and is accompanied by all associated warranties, conditions, limitations, and notices. TI is not responsible or liable for such altered documentation. Information of third parties may be subject to additional restrictions.

Resale of TI components or services with statements different from or beyond the parameters stated by TI for that component or service voids all express and any implied warranties for the associated TI component or service and is an unfair and deceptive business practice. TI is not responsible or liable for any such statements.

Buyer acknowledges and agrees that it is solely responsible for compliance with all legal, regulatory and safety-related requirements concerning its products, and any use of TI components in its applications, notwithstanding any applications-related information or support that may be provided by TI. Buyer represents and agrees that it has all the necessary expertise to create and implement safeguards which anticipate dangerous consequences of failures, monitor failures and their consequences, lessen the likelihood of failures that might cause harm and take appropriate remedial actions. Buyer will fully indemnify TI and its representatives against any damages arising out of the use of any TI components in safety-critical applications.

In some cases, TI components may be promoted specifically to facilitate safety-related applications. With such components, TI's goal is to help enable customers to design and create their own end-product solutions that meet applicable functional safety standards and requirements. Nonetheless, such components are subject to these terms.

No TI components are authorized for use in FDA Class III (or similar life-critical medical equipment) unless authorized officers of the parties have executed a special agreement specifically governing such use.

Only those TI components which TI has specifically designated as military grade or "enhanced plastic" are designed and intended for use in military/aerospace applications or environments. Buyer acknowledges and agrees that any military or aerospace use of TI components which have *not* been so designated is solely at the Buyer's risk, and that Buyer is solely responsible for compliance with all legal and regulatory requirements in connection with such use.

TI has specifically designated certain components as meeting ISO/TS16949 requirements, mainly for automotive use. In any case of use of non-designated products, TI will not be responsible for any failure to meet ISO/TS16949.

### Products

Audio	<a href="http://www.ti.com/audio">www.ti.com/audio</a>
Amplifiers	<a href="http://amplifier.ti.com">amplifier.ti.com</a>
Data Converters	<a href="http://dataconverter.ti.com">dataconverter.ti.com</a>
DLP® Products	<a href="http://www.dlp.com">www.dlp.com</a>
DSP	<a href="http://dsp.ti.com">dsp.ti.com</a>
Clocks and Timers	<a href="http://www.ti.com/clocks">www.ti.com/clocks</a>
Interface	<a href="http://interface.ti.com">interface.ti.com</a>
Logic	<a href="http://logic.ti.com">logic.ti.com</a>
Power Mgmt	<a href="http://power.ti.com">power.ti.com</a>
Microcontrollers	<a href="http://microcontroller.ti.com">microcontroller.ti.com</a>
RFID	<a href="http://www.ti-rfid.com">www.ti-rfid.com</a>
OMAP Applications Processors	<a href="http://www.ti.com/omap">www.ti.com/omap</a>
Wireless Connectivity	<a href="http://www.ti.com/wirelessconnectivity">www.ti.com/wirelessconnectivity</a>

### Applications

Automotive and Transportation	<a href="http://www.ti.com/automotive">www.ti.com/automotive</a>
Communications and Telecom	<a href="http://www.ti.com/communications">www.ti.com/communications</a>
Computers and Peripherals	<a href="http://www.ti.com/computers">www.ti.com/computers</a>
Consumer Electronics	<a href="http://www.ti.com/consumer-apps">www.ti.com/consumer-apps</a>
Energy and Lighting	<a href="http://www.ti.com/energy">www.ti.com/energy</a>
Industrial	<a href="http://www.ti.com/industrial">www.ti.com/industrial</a>
Medical	<a href="http://www.ti.com/medical">www.ti.com/medical</a>
Security	<a href="http://www.ti.com/security">www.ti.com/security</a>
Space, Avionics and Defense	<a href="http://www.ti.com/space-avionics-defense">www.ti.com/space-avionics-defense</a>
Video and Imaging	<a href="http://www.ti.com/video">www.ti.com/video</a>

### TI E2E Community

[e2e.ti.com](http://e2e.ti.com)