

LMV227 Production RF Tested, RF Power Detector for CDMA and WCDMA

Check for Samples: [LMV227](#)

FEATURES

- 30 dB Linear in dB Power Detection Range
- Output Voltage Range 0.2 to 2V
- Logic Low Shutdown
- Multi-band Operation from 450 MHz to 2000 MHz
- Accurate Temperature Compensation

APPLICATIONS

- CDMA RF Power Control
- WCDMA RF Power Control
- CDMA2000 RF Power Control
- PA Modules

DESCRIPTION

The LMV227 is a 30 dB RF power detector intended for use in CDMA and WCDMA applications. The device has an RF frequency range from 450 MHz to 2 GHz. It provides an accurate temperature and supply compensated output voltage that relates linearly to the RF input power in dBm. The circuit operates with a single supply from 2.7V to 5V. The LMV227 has an integrated filter for low-ripple average power detection of CDMA signals with 30 dB dynamic range. Additional filtering can be applied using a single external capacitor.

The LMV227 has an RF power detection range from -30 dBm to 0 dBm and is ideally suited for direct use in combination with resistive taps. The device is active for Enable = HI, otherwise it goes into a low power consumption shutdown mode. During shutdown the output will be LOW. The output voltage ranges from 0.2V to 2V and can be scaled down to meet ADC input range requirements. The output signal bandwidth can optionally be lowered externally as well.

TYPICAL APPLICATION

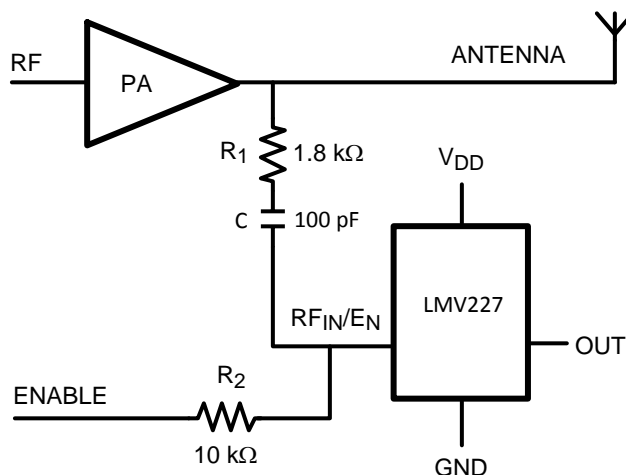

Please be aware that an important notice concerning availability, standard warranty, and use in critical applications of Texas Instruments semiconductor products and disclaimers thereto appears at the end of this data sheet.

All trademarks are the property of their respective owners.



These devices have limited built-in ESD protection. The leads should be shorted together or the device placed in conductive foam during storage or handling to prevent electrostatic damage to the MOS gates.

ABSOLUTE MAXIMUM RATINGS ⁽¹⁾⁽²⁾

Supply Voltage	V _{DD} - GND	6.0V Max
ESD Tolerance ⁽³⁾	Human Body Model	2000V
	Machine Model	200V
Storage Temperature Range		-65°C to 150°C
Junction Temperature ⁽⁴⁾		150°C Max
Mounting Temperature	Infrared or convection (20 sec)	235°C

- (1) Absolute Maximum Ratings indicate limits beyond which damage to the device may occur. Operating Ratings indicate conditions for which the device is intended to be functional, but specific performance is not ensured. For ensured specifications and the test conditions, see the Electrical Characteristics.
- (2) If Military/Aerospace specified devices are required, please contact the TI Sales Office/ Distributors for availability and specifications.
- (3) Human body model: 1.5 kΩ in series with 100 pF. Machine model, 0Ω in series with 100 pF.
- (4) The maximum power dissipation is a function of T_{J(MAX)}, θ_{JA} and T_A. The maximum allowable power dissipation at any ambient temperature is P_D = (T_{J(MAX)} - T_A)/θ_{JA}. All numbers apply for packages soldered directly into a PC board

OPERATING RATINGS ⁽¹⁾

Supply Voltage	2.7V to 5.5V
Temperature Range	-40°C to +85°C

- (1) Absolute Maximum Ratings indicate limits beyond which damage to the device may occur. Operating Ratings indicate conditions for which the device is intended to be functional, but specific performance is not ensured. For ensured specifications and the test conditions, see the Electrical Characteristics.

2.7 DC AND AC ELECTRICAL CHARACTERISTICS

Unless otherwise specified, all limits are specified to V_{DD} = 2.7V; T_J = 25°C. **Boldface** limits apply at temperature extremes. ⁽¹⁾

Symbol	Parameter	Condition	Min	Typ	Max	Units
I _{DD}	Supply Current	Active mode: RF _{IN} /E _N = V _{DD} (DC), No RF Input Power Present.		4.9	7 8	mA
		Shutdown: RF _{IN} /E _N = GND (DC), No RF Input Power Present.		0.6	4.5	μA
V _{LOW}	E _N Logic Low Input Level ⁽²⁾				0.8	V
V _{HIGH}	E _N Logic High Input Level ⁽²⁾		1.8			V
t _{on}	Turn-on- Time	No RF Input Power Present		2.1		μs
t _r	Rise Time ⁽³⁾	Step from No Power to 0 dBm Applied		4.5		μs
I _{EN}	Current into RF _{IN} /E _N Pin				1	μA
P _{IN}	Input Power Range ⁽⁴⁾			-30 0		dBm
				-43 -13		dBV
	Logarithmic Slope ⁽⁵⁾	900 MHz		43.3		mV/dB
		1800 MHz		43.9		
		1855 MHz	36	43.5	51	
		1900 MHz		44.0		
		2000 MHz		43.2		

- (1) Electrical Table values apply only for factory testing conditions at the temperature indicated. Factory testing conditions result in very limited self-heating of the device such that T_J = T_A. No ensured specification of parametric performance is indicated in the electrical tables under conditions of internal self-heating where T_J > T_A.
- (2) All limits are specified by design or statistical analysis
- (3) Typical values represent the most likely parametric norm.
- (4) Power in dBV = dBm -13 when the impedance is 50Ω.
- (5) Device is set in active mode with a 10 kΩ resistor from V_{DD} to RF_{IN}/E_N. RF signal is applied using a 50Ω RF signal generator AC coupled to the RF_{IN}/E_N pin using a 100 pF coupling capacitor.

2.7 DC AND AC ELECTRICAL CHARACTERISTICS (continued)

Unless otherwise specified, all limits are specified to $V_{DD} = 2.7V$; $T_J = 25^\circ C$. **Boldface** limits apply at temperature extremes. ⁽¹⁾

Symbol	Parameter	Condition	Min	Typ	Max	Units
	Logarithmic Intercept ⁽⁵⁾	900 MHz		-46.7		dBm
		1800 MHz		-44.1		
		1855 MHz	-56	-44.3	-33	
		1900 MHz		-42.8		
		2000 MHz		-43.7		
V_{OUT}	Output Voltage	No RF Input Power Present		208	350	mV
R_{OUT}	Output Impedance	No RF Input Power Present		20.3	29 34	k Ω
e_n	Output Referred Noise	RF Input = 1800 MHz, -10 dBm, Measured at 10 kHz		700		nV/ \sqrt{Hz}
	Variation over Temperature	900 MHz, $RF_{IN} = 0$ dBm Referred to 25°C		+0.64 -1.07		dB
		1800 MHz, $RF_{IN} = 0$ dBm Referred to 25°C		+0.09 -0.86		
		1900 MHz, $RF_{IN} = 0$ dBm Referred to 25°C		+0 -0.69		
		2000 MHz, $RF_{IN} = 0$ dBm Referred to 25°C		+0 -0.86		

5.0 DC AND AC ELECTRICAL CHARACTERISTICS

Unless otherwise specified, all limits are specified to $V_{DD} = 5.0V$; $T_J = 25^\circ C$. **Boldface** limits apply at temperature extremes. ⁽¹⁾

Symbol	Parameter	Condition	Min	Typ	Max	Units
I_{DD}	Supply Current	Active Mode: $RF_{IN}/E_N = V_{DD}$ (DC), No RF Input Power Present.		5.3	7 9	mA
		Shutdown: $RF_{IN}/E_N = GND$ (DC), No RF Input Power Present.		0.49	4.5	
V_{LOW}	E_N Logic Low Input Level ⁽²⁾				0.8	V
V_{HIGH}	E_N Logic High Input Level ⁽²⁾		1.8			V
t_{on}	Turn-on- Time	No RF Input Power Present		2.1		μs
t_r	Rise Time ⁽³⁾	Step from No Power to 0 dBm Applied		4.5		μs
I_{EN}	Current Into RF_{IN}/E_N Pin				1	μA
$P_{IN, MIN}$	Input Power Range ⁽⁴⁾			-30 0		dBm
				-43 -13		
	Logarithmic Slope ⁽⁵⁾	900 MHz		43.6		mV/dB
		1800 MHz		44.5		
		1900 MHz		44.5		
		2000 MHz		43.7		
	Logarithmic Intercept ⁽⁵⁾	900 MHz		-48.1		dBm
		1800 MHz		-45.6		
		1900 MHz		-44.2		
		2000 MHz		-45.6		
V_{OUT}	Output Voltage	No RF Input Power Present		211	400	mV

(1) Electrical Table values apply only for factory testing conditions at the temperature indicated. Factory testing conditions result in very limited self-heating of the device such that $T_J = T_A$. No ensured specification of parametric performance is indicated in the electrical tables under conditions of internal self-heating where $T_J > T_A$.

(2) All limits are specified by design or statistical analysis

(3) Typical values represent the most likely parametric norm.

(4) Power in dBV = dBm -13 when the impedance is 50 Ω .

(5) Device is set in active mode with a 10 k Ω resistor from V_{DD} to RF_{IN}/E_N . RF signal is applied using a 50 Ω RF signal generator AC coupled to the RF_{IN}/E_N pin using a 100 pF coupling capacitor.

5.0 DC AND AC ELECTRICAL CHARACTERISTICS (continued)

Unless otherwise specified, all limits are specified to $V_{DD} = 5.0V$; $T_J = 25^{\circ}C$. **Boldface** limits apply at temperature extremes. ⁽¹⁾

Symbol	Parameter	Condition	Min	Typ	Max	Units
R_{OUT}	Output Impedance	No RF Input Power Present		23.4	29 31	$k\Omega$
e_n	Output Referred Noise	RF Input = 1800 MHz, -10 dBm, Measured at 10 kHz		700		nV/\sqrt{Hz}
	Variation over Temperature	900 MHz, $RF_{IN} = 0$ dBm Referred to $25^{\circ}C$		+0.89 -1.16		dB
		1800 MHz, $RF_{IN} = 0$ dBm Referred to $25^{\circ}C$		+0.3 -0.82		
		1900 MHz, $RF_{IN} = 0$ dBm Referred to $25^{\circ}C$		+0.34 -0.63		
		2000 MHz $RF_{IN} = 0$ dBm Referred to $25^{\circ}C$		+0.22 -0.75		

CONNECTION DIAGRAM

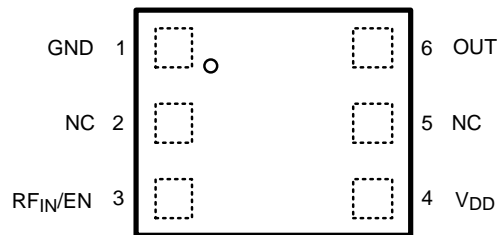
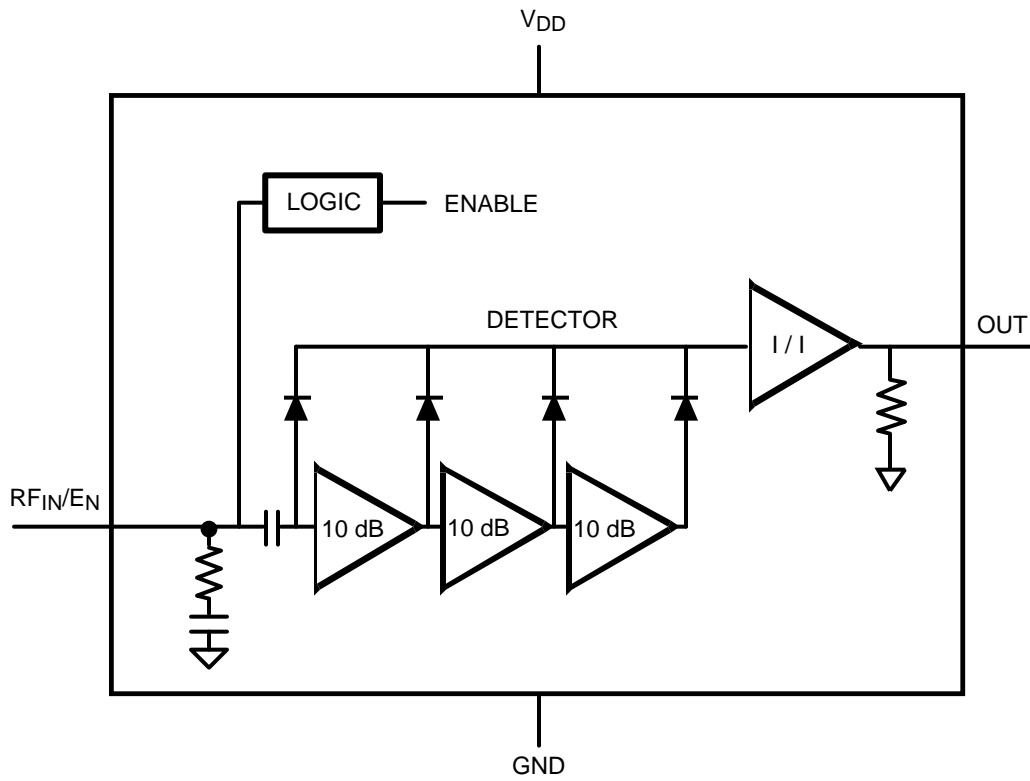

Figure 1. 6-pin WSON Top View

PIN DESCRIPTIONS

	Pin	Name	Description
Power Supply	4	V_{DD}	Positive supply voltage
	1	GND	Power ground
	3	RF_{IN}/E_N	DC voltage determines enable state of the device (HIGH = device active). AC voltage is the RF input signal to the detector (beyond 450 MHz). The RF_{IN}/E_N pin is internally terminated with 50Ω in series with $45 pF$.
Output	6	OUT	Ground referenced detector output voltage (linear in dBm)

BLOCK DIAGRAM



TYPICAL PERFORMANCE CHARACTERISTICS

Unless otherwise specified, $V_{DD} = 2.7V$, $T_J = 25^{\circ}C$.

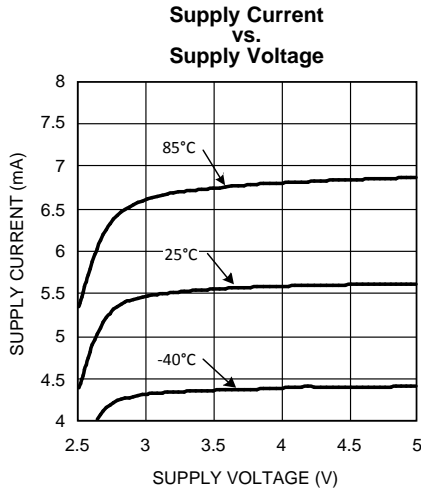

Figure 2.

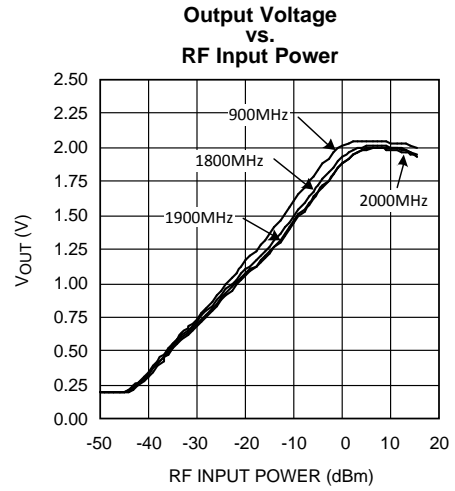

Figure 3.

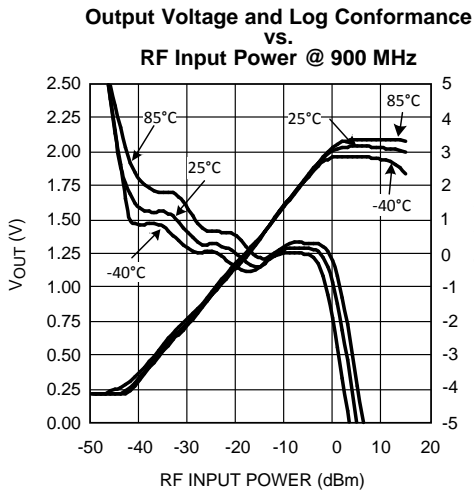

Figure 4.

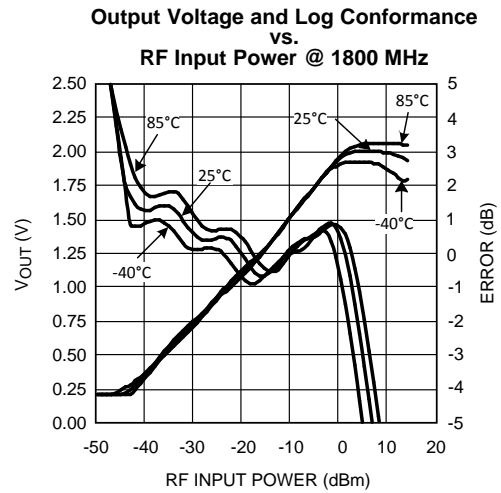

Figure 5.

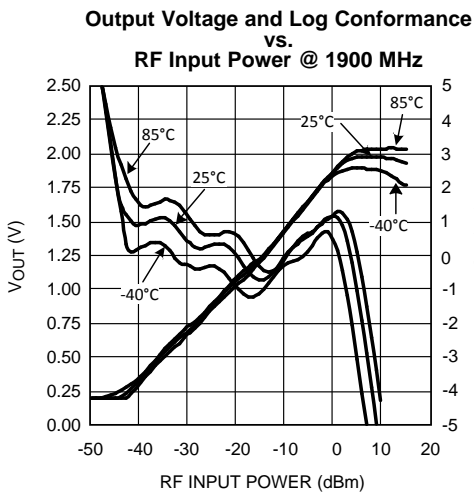

Figure 6.

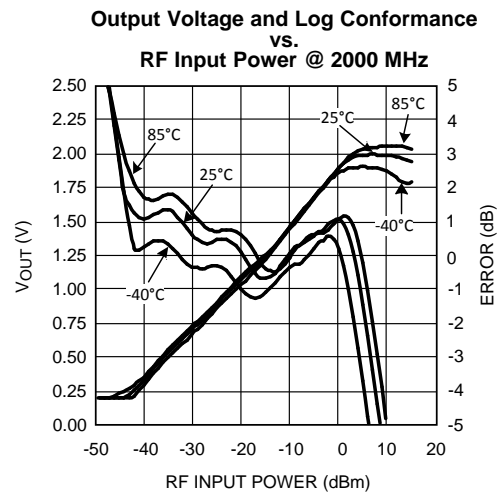

Figure 7.

TYPICAL PERFORMANCE CHARACTERISTICS (continued)

Unless otherwise specified, $V_{DD} = 2.7V$, $T_J = 25^\circ C$.

Logarithmic Slope vs. Frequency

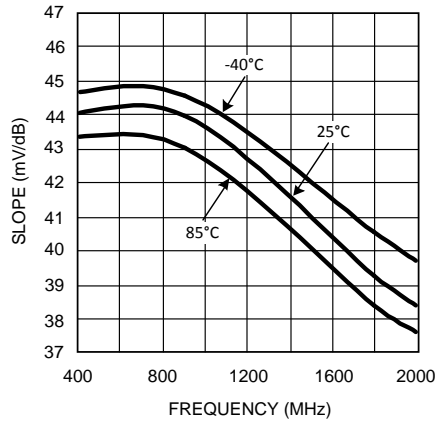

Figure 8.

Logarithmic Intercept vs. Frequency

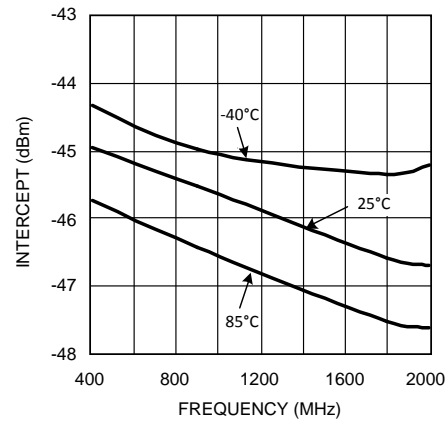

Figure 9.

Output Variation vs. RF Input Power Normalized to 25°C @ 900 MHz

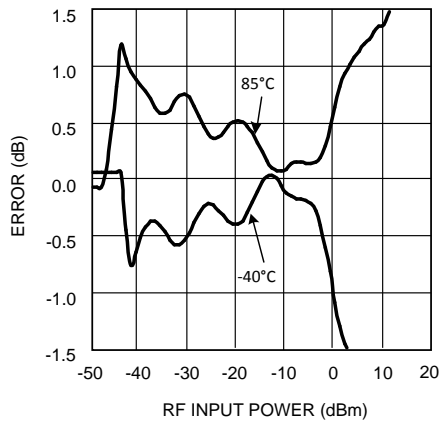

Figure 10.

Output Variation vs. RF Input Power Normalized to 25°C @ 1800 MHz

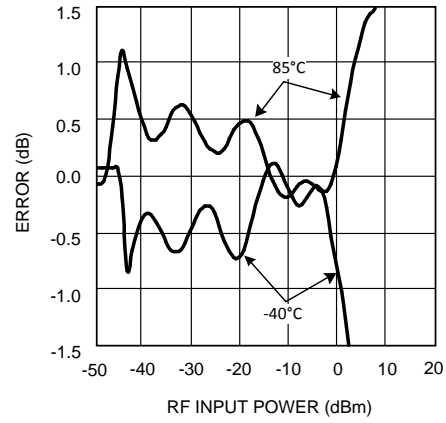

Figure 11.

Output Variation vs. RF Input Power Normalized to 25°C @ 1900 MHz

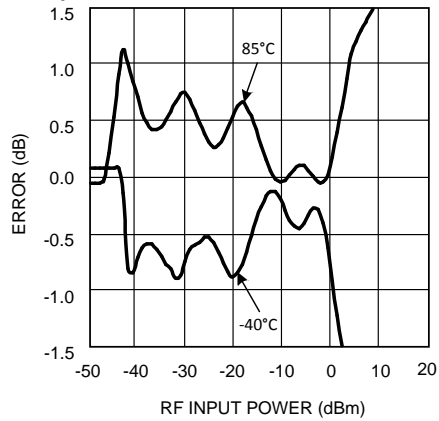

Figure 12.

Output Variation vs. RF Input Power Normalized to 25°C @ 2000 MHz

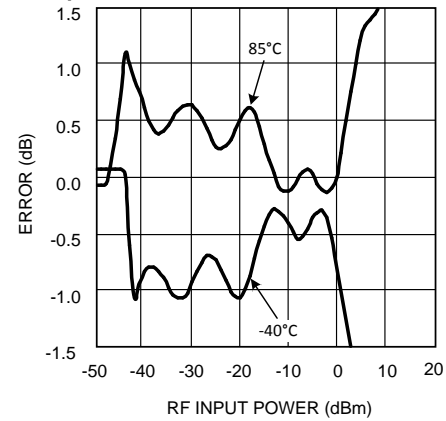

Figure 13.

TYPICAL PERFORMANCE CHARACTERISTICS (continued)

Unless otherwise specified, $V_{DD} = 2.7V$, $T_J = 25^\circ C$.

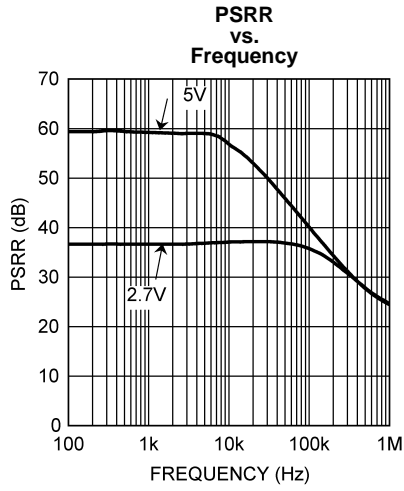

Figure 14.

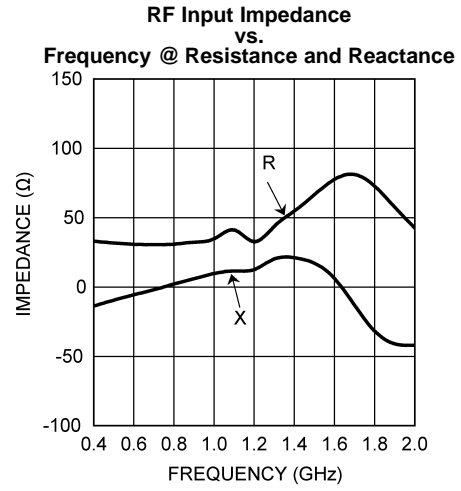

Figure 15.

APPLICATION NOTES

CONFIGURING A TYPICAL APPLICATION

The LMV227 is a power detector intended for CDMA and WCDMA applications. Power measured on its input translates to a DC voltage on the output through a linear-in-dB response. The detector is especially suited for power measurements via a high-resistive tap, which eliminates the need for a directional coupler. In order to match the dynamic output range of the power amplifier (PA) with the dynamic range of the LMV227's input, the high resistive tap needs to be configured correctly.

Input Attenuation

The constant input impedance of the device enables the realization of a frequency independent input attenuation to adjust the LMV227's dynamic range to the dynamic range of the PA. Resistor R_1 and the 50Ω input resistance of the device realize this attenuation (Figure 16). To minimize insertion loss, resistor R_1 needs to be sufficiently large. The following example demonstrates how to determine the proper value for R_1 .

Suppose the useful output power of the PA ranges up to +31 dBm and the LMV227 can handle input power levels up to 0 dBm. Hence, R_1 should realize a minimum attenuation of $31 - 0 = 31$ dB. The attenuation realized by R_1 and the effective input resistance R_{IN} of the detector equals:

$$A_{dB} = 20 \cdot \text{LOG} \left[1 + \frac{R_1}{R_{IN}} \right] = 31 \text{ dB} \quad (1)$$

Solving this expression for R_1 , using that $R_{IN} = 50\Omega$, yields:

$$R_1 = \left[10^{\frac{A_{dB}}{20}} - 1 \right] \cdot R_{IN} = \left[10^{\frac{31}{20}} - 1 \right] \cdot 50 = 1724\Omega \quad (2)$$

In Figure 16, R_1 is set to 1800Ω resulting in an attenuation of 31.4 dB

DC and AC Behavior of the RF_{IN}/E_N Pin

The LMV227 RF_{IN}/E_N pin has 2 functions combined:

- Shutdown functionality
- Power detection

The capacitor C and the resistor R_2 of Figure 16 separate the DC shutdown functionality from the AC power measurement. The device is active when Enable = HI, otherwise it goes into a low power consumption shutdown mode. During shutdown the output will be LOW.

Capacitor C should be chosen sufficiently large to ensure a corner frequency far below the lowest input frequency to be measured. The corner frequency can be calculated using:

$$f = \frac{1}{2\pi(R_1 + R_{IN}) \frac{C \cdot C_{IN}}{C + C_{IN}}} \quad (3)$$

Where $R_{IN} = 50\Omega$, $C_{IN} = 45$ pF typical.

With $R_1 = 1800\Omega$ and C is 100 pF, this results in a corner frequency of 2.8 MHz

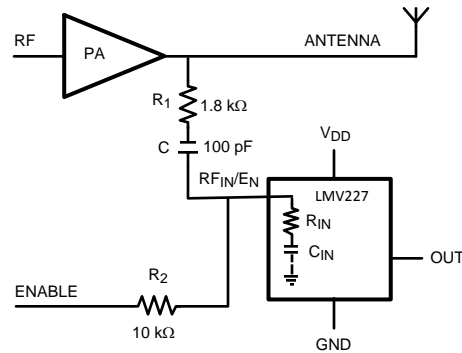

Figure 16. Typical Application

The output voltage is linear with the logarithm of the input power, often called "linear-in-dB". Figure 17 shows the typical output voltage versus PA output power of the LMV227 setup as depicted in Figure 16.

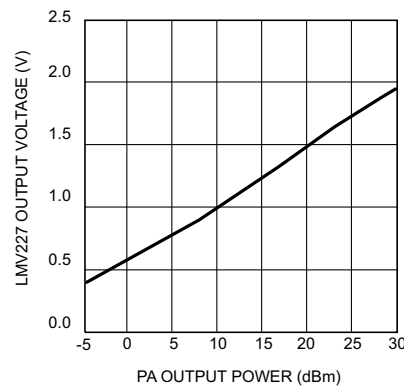

Figure 17. Typical Power Detector Response, V_{OUT} vs. PA Output Power

OUTPUT RIPPLE DUE TO AM MODULATION

A CDMA modulated carrier wave generally contains some amplitude modulation that might disturb the RF power measurement used for controlling the PA. This section explains the relation between amplitude modulation in the RF signal and the ripple on the output of the LMV227. Expressions are provided to estimate this ripple on the output. The ripple can be further reduced by connecting an additional capacitor to the output of the LMV227 to ground.

Estimating Output Ripple

The CDMA modulated RF input signal of Figure 18 can be described as:

$$V_{IN}(t) = V_{IN} [1 + \mu(t)] \cos(2 \cdot \pi \cdot f \cdot t) \quad (4)$$

In which the amplitude modulation $\mu(t)$ can be between -1 and 1 .

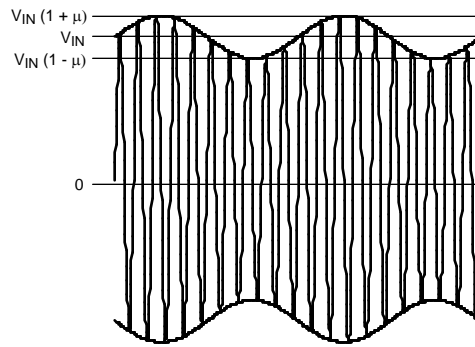

Figure 18. AM Modulated RF Signal

The ripple observed on the output of the detector equals the detectors response to variation on the input due to AM modulation (Figure 18). This signal has a maximum amplitude $V_{IN}(1+\mu)$ and a minimum amplitude $V_{IN}(1-\mu)$, where $1+\mu$ can be maximum 2 and $1-\mu$ can be minimum 0. The ripple can be described with the formula:

$$V_{RIPPLE} = V_Y \left[\underset{P_{INMAX} \text{ IN dBm}}{10 \text{ LOG} \left[\frac{V_{IN}^2 (1 + \mu)^2}{2R_{IN}} \right] + 30} \right] - V_Y \left[\underset{P_{INMIN} \text{ IN dBm}}{10 \text{ LOG} \left[\frac{V_{IN}^2 (1 - \mu)^2}{2R_{IN}} \right] + 30} \right] \quad (5)$$

where V_Y is the slope of the detection curve (Figure 19) and μ is the modulation index. Equation 5 can be reduced to:

$$V_{RIPPLE} = V_Y \cdot 20 \text{ LOG} \left[\frac{1 + \mu}{1 - \mu} \right] \quad (6)$$

Consequently, the ripple is independent of the average input power of the RF input signal and only depends on the logarithmic slope V_Y and the ratio of the maximum and the minimum input signal amplitude.

For CDMA, the ratio of the maximum and the minimum input signal amplitude modulation is typically in the order of 5 to 6 dB, which is equivalent to a modulation index μ of 0.28 to 0.33.

A further understanding of the equation above can be achieved via the knowledge that the output voltage V_{OUT} of the LMV227 is linear in dB, or proportional to the input power P_{IN} in dBm. As discussed earlier, CDMA contains amplitude modulation in the order of 5 to 6 dB. Since the transfer is linear in dB, the output voltage V_{OUT} will vary linearly over about 5 to 6 dB in the curve (Figure 19).

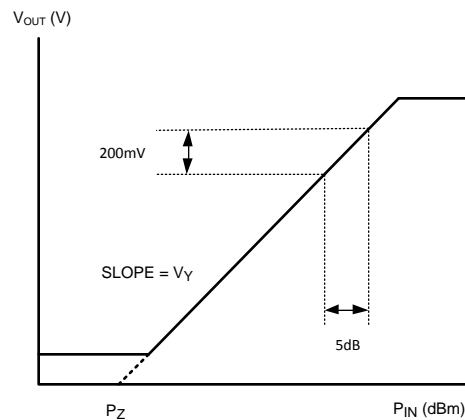

Figure 19. V_{OUT} vs. RF Input Power P_{IN}

Besides the ripple due to AM modulation, the log-conformance error contributes to a variation in V_{OUT} . For details see the [typical performance characteristics](#) curves. The output voltage variation ΔV_{OUT} thus is always the same for RF input signals which fall within the linear range (in dB) of the detector plus the log-conformance error:

$$\Delta V_O = V_Y \cdot \Delta P_{IN} + \text{Log Conformance Error} \quad (7)$$

In which V_Y is the slope of the curve. The log-conformance error is usually much smaller than the ripple due to AM modulation. In case of the LMV227, $V_Y = 40 \text{ mV/dB}$. With $\Delta P_{IN} = 5 \text{ dB}$ for CDMA, the $\Delta V_O = 200 \text{ mV}_{PP}$. This is valid for all V_{OUT} .

Output Ripple With Additional Filtering

The calculated result above is for an unfiltered configuration. When a low pass filter is used by shunting a capacitor of e.g. $C_{OUT} = 1.5 \text{ nF}$ at the output of the LMV227 to ground, this ripple is further attenuated. The cut-off frequency follows from:

$$f_C = \frac{1}{2 \pi C_{OUT} R_O} \quad (8)$$

With the output resistance of the LMV227 $R_O = 19.8 \text{ k}\Omega$ typical and $C_{OUT} = 1.5 \text{ nF}$, the cut-off frequency equals $f_C = 5.36 \text{ kHz}$. A 100 kHz AM signal then gets attenuated by $5.36/100$ or 25.4 dB. The remaining ripple will be less than 20 mV. With a slope of 40 mV/dB this translates into an error of less than 0.5 dB.

Output Ripple Measurement

[Figure 20](#) shows the ripple reduction that can be achieved by adding additional capacitance on the output of the LMV227. The RF signal of 900 MHz is AM modulated with a 100 kHz sinewave and a modulation index of 0.3. The RF input power is swept while the modulation index remains unchanged. Without additional capacitance the ripple is about 200 mV_{PP}. Connecting a capacitor of 1.5 nF at the output to ground, results in a ripple of 12 mV_{PP}. The attenuation with a 1.5 nF capacitor is then $20 \cdot \log(200/12) = 24.4 \text{ dB}$. This is very close to the number calculated in the previous paragraph.

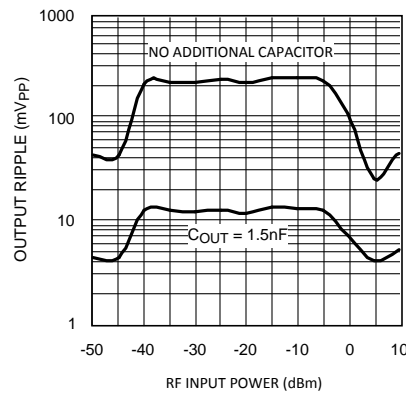

Figure 20. Output Ripple vs. RF Input Power

PRINCIPLE OF OPERATION

The logarithmic response of the LMV227 is implemented by a de-modulating logarithmic amplifier as shown in [Figure 21](#). The logarithmic amplifier consists of a number of cascaded linear gain cells. With these gain cells, a piecewise approximation of the logarithmic function is constructed.

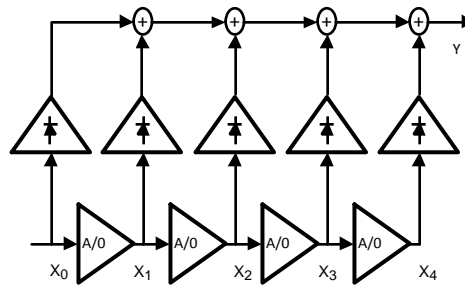

Figure 21. Logarithmic Amplifier

Every gain cell has a response according to Figure 22. At a certain threshold (E_K), the gain cell starts to saturate, which means that the gain drops to zero. The output of gain cell 1 is connected to the input of gain cell 2 and so on.

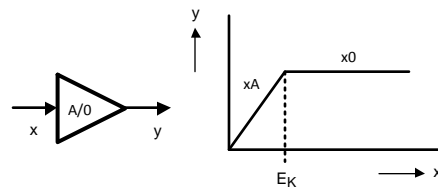

Figure 22. Gain Cell

All gain cell outputs are AM-demodulated with a peak detector and summed together. This results in a logarithmic function. The logarithmic range is about:

$$20 \cdot n \cdot \log(A) \tag{9}$$

where,

n = number of gain cells

A = gain per gaincell

Figure 23 shows a logarithmic function on a linear scale and the piecewise approximation of the logarithmic function.

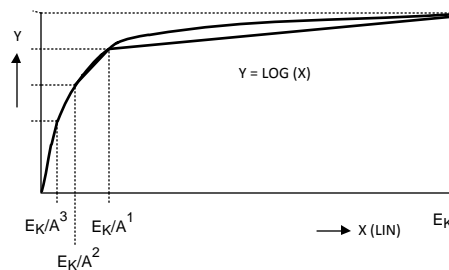

Figure 23. Log-Function on Lin Scale

Figure 24 shows a logarithmic function on a logarithmic scale and the piecewise approximation of the logarithmic function.

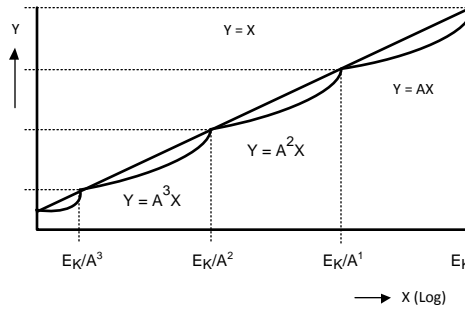

Figure 24. Log-Function on Log Scale

The maximum error for this approximation occurs at the geometric mean of a gain section, which is e.g. for the third segment:

$$\sqrt{\frac{E_K}{A^2} \cdot \frac{E_K}{A^1}} = \frac{E_K}{A\sqrt{A}} \tag{10}$$

The size of the error increases with distance between the thresholds.

LAYOUT CONSIDERATIONS

For a properly functioning part a good board layout is necessary. Special care should be taken for the series resistance R_1 (Figure 16) that determines the attenuation. This series resistance should have a sufficiently high bandwidth. The bandwidth will drop when the parasitic capacitance of the resistance is too high, which will cause a significant attenuation drop at the GSM frequencies and can cause non-linear behavior. To reduce the parasitic capacitance across resistor R_1 , it can be composed of several resistor in series in stead of a single component.

REVISION HISTORY

Changes from Revision C (March 2013) to Revision D	Page
<hr/> <ul style="list-style-type: none">• Changed layout of National Data Sheet to TI format	<hr/> 14

PACKAGING INFORMATION

Orderable Device	Status (1)	Package Type	Package Drawing	Pins	Package Qty	Eco Plan (2)	Lead/Ball Finish	MSL Peak Temp (3)	Op Temp (°C)	Top-Side Markings (4)	Samples
LMV227SD/NOPB	ACTIVE	WSON	NGF	6	1000	Green (RoHS & no Sb/Br)	CU SN	Level-1-260C-UNLIM		A88	Samples
LMV227SDX/NOPB	ACTIVE	WSON	NGF	6	4500	Green (RoHS & no Sb/Br)	CU SN	Level-1-260C-UNLIM		A88	Samples

(1) The marketing status values are defined as follows:

ACTIVE: Product device recommended for new designs.

LIFEBUY: TI has announced that the device will be discontinued, and a lifetime-buy period is in effect.

NRND: Not recommended for new designs. Device is in production to support existing customers, but TI does not recommend using this part in a new design.

PREVIEW: Device has been announced but is not in production. Samples may or may not be available.

OBSOLETE: TI has discontinued the production of the device.

(2) Eco Plan - The planned eco-friendly classification: Pb-Free (RoHS), Pb-Free (RoHS Exempt), or Green (RoHS & no Sb/Br) - please check <http://www.ti.com/productcontent> for the latest availability information and additional product content details.

TBD: The Pb-Free/Green conversion plan has not been defined.

Pb-Free (RoHS): TI's terms "Lead-Free" or "Pb-Free" mean semiconductor products that are compatible with the current RoHS requirements for all 6 substances, including the requirement that lead not exceed 0.1% by weight in homogeneous materials. Where designed to be soldered at high temperatures, TI Pb-Free products are suitable for use in specified lead-free processes.

Pb-Free (RoHS Exempt): This component has a RoHS exemption for either 1) lead-based flip-chip solder bumps used between the die and package, or 2) lead-based die adhesive used between the die and leadframe. The component is otherwise considered Pb-Free (RoHS compatible) as defined above.

Green (RoHS & no Sb/Br): TI defines "Green" to mean Pb-Free (RoHS compatible), and free of Bromine (Br) and Antimony (Sb) based flame retardants (Br or Sb do not exceed 0.1% by weight in homogeneous material)

(3) MSL, Peak Temp. -- The Moisture Sensitivity Level rating according to the JEDEC industry standard classifications, and peak solder temperature.

(4) Multiple Top-Side Markings will be inside parentheses. Only one Top-Side Marking contained in parentheses and separated by a "~" will appear on a device. If a line is indented then it is a continuation of the previous line and the two combined represent the entire Top-Side Marking for that device.

Important Information and Disclaimer: The information provided on this page represents TI's knowledge and belief as of the date that it is provided. TI bases its knowledge and belief on information provided by third parties, and makes no representation or warranty as to the accuracy of such information. Efforts are underway to better integrate information from third parties. TI has taken and continues to take reasonable steps to provide representative and accurate information but may not have conducted destructive testing or chemical analysis on incoming materials and chemicals. TI and TI suppliers consider certain information to be proprietary, and thus CAS numbers and other limited information may not be available for release.

In no event shall TI's liability arising out of such information exceed the total purchase price of the TI part(s) at issue in this document sold by TI to Customer on an annual basis.

TAPE AND REEL INFORMATION



QUADRANT ASSIGNMENTS FOR PIN 1 ORIENTATION IN TAPE



*All dimensions are nominal

Device	Package Type	Package Drawing	Pins	SPQ	Reel Diameter (mm)	Reel Width W1 (mm)	A0 (mm)	B0 (mm)	K0 (mm)	P1 (mm)	W (mm)	Pin1 Quadrant
LMV227SD/NOPB	WSON	NGF	6	1000	178.0	12.4	2.8	2.5	1.0	8.0	12.0	Q1
LMV227SDX/NOPB	WSON	NGF	6	4500	330.0	12.4	2.8	2.5	1.0	8.0	12.0	Q1

TAPE AND REEL BOX DIMENSIONS

*All dimensions are nominal

Device	Package Type	Package Drawing	Pins	SPQ	Length (mm)	Width (mm)	Height (mm)
LMV227SD/NOPB	WSON	NGF	6	1000	210.0	185.0	35.0
LMV227SDX/NOPB	WSON	NGF	6	4500	367.0	367.0	35.0

NGF0006A

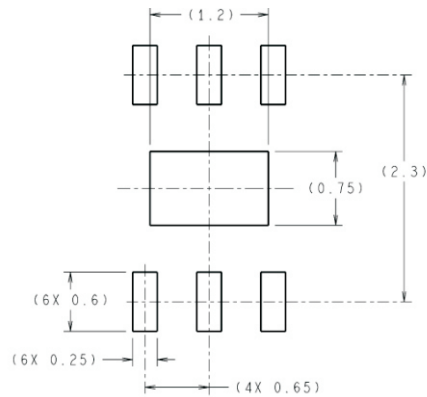

DIMENSIONS ARE IN MILLIMETERS
DIMENSIONS IN () FOR REFERENCE ONLY



RECOMMENDED LAND PATTERN

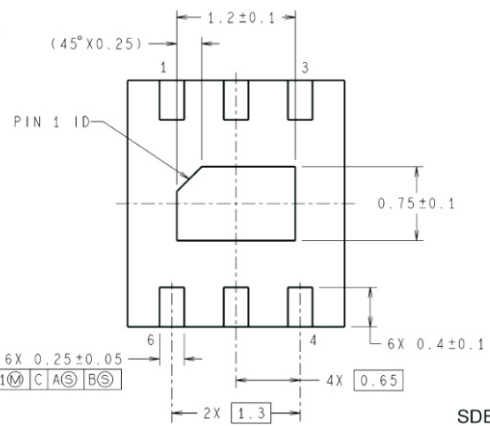
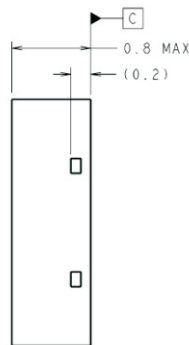
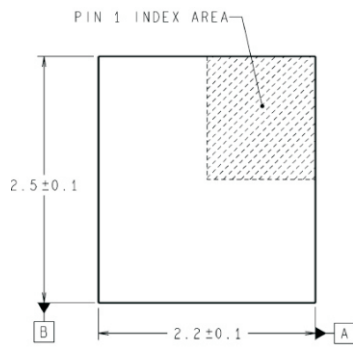

SDB06A (Rev A)

IMPORTANT NOTICE

Texas Instruments Incorporated and its subsidiaries (TI) reserve the right to make corrections, enhancements, improvements and other changes to its semiconductor products and services per JESD46, latest issue, and to discontinue any product or service per JESD48, latest issue. Buyers should obtain the latest relevant information before placing orders and should verify that such information is current and complete. All semiconductor products (also referred to herein as "components") are sold subject to TI's terms and conditions of sale supplied at the time of order acknowledgment.

TI warrants performance of its components to the specifications applicable at the time of sale, in accordance with the warranty in TI's terms and conditions of sale of semiconductor products. Testing and other quality control techniques are used to the extent TI deems necessary to support this warranty. Except where mandated by applicable law, testing of all parameters of each component is not necessarily performed.

TI assumes no liability for applications assistance or the design of Buyers' products. Buyers are responsible for their products and applications using TI components. To minimize the risks associated with Buyers' products and applications, Buyers should provide adequate design and operating safeguards.

TI does not warrant or represent that any license, either express or implied, is granted under any patent right, copyright, mask work right, or other intellectual property right relating to any combination, machine, or process in which TI components or services are used. Information published by TI regarding third-party products or services does not constitute a license to use such products or services or a warranty or endorsement thereof. Use of such information may require a license from a third party under the patents or other intellectual property of the third party, or a license from TI under the patents or other intellectual property of TI.

Reproduction of significant portions of TI information in TI data books or data sheets is permissible only if reproduction is without alteration and is accompanied by all associated warranties, conditions, limitations, and notices. TI is not responsible or liable for such altered documentation. Information of third parties may be subject to additional restrictions.

Resale of TI components or services with statements different from or beyond the parameters stated by TI for that component or service voids all express and any implied warranties for the associated TI component or service and is an unfair and deceptive business practice. TI is not responsible or liable for any such statements.

Buyer acknowledges and agrees that it is solely responsible for compliance with all legal, regulatory and safety-related requirements concerning its products, and any use of TI components in its applications, notwithstanding any applications-related information or support that may be provided by TI. Buyer represents and agrees that it has all the necessary expertise to create and implement safeguards which anticipate dangerous consequences of failures, monitor failures and their consequences, lessen the likelihood of failures that might cause harm and take appropriate remedial actions. Buyer will fully indemnify TI and its representatives against any damages arising out of the use of any TI components in safety-critical applications.

In some cases, TI components may be promoted specifically to facilitate safety-related applications. With such components, TI's goal is to help enable customers to design and create their own end-product solutions that meet applicable functional safety standards and requirements. Nonetheless, such components are subject to these terms.

No TI components are authorized for use in FDA Class III (or similar life-critical medical equipment) unless authorized officers of the parties have executed a special agreement specifically governing such use.

Only those TI components which TI has specifically designated as military grade or "enhanced plastic" are designed and intended for use in military/aerospace applications or environments. Buyer acknowledges and agrees that any military or aerospace use of TI components which have **not** been so designated is solely at the Buyer's risk, and that Buyer is solely responsible for compliance with all legal and regulatory requirements in connection with such use.

TI has specifically designated certain components as meeting ISO/TS16949 requirements, mainly for automotive use. In any case of use of non-designated products, TI will not be responsible for any failure to meet ISO/TS16949.

Products

Audio	www.ti.com/audio
Amplifiers	amplifier.ti.com
Data Converters	dataconverter.ti.com
DLP® Products	www.dlp.com
DSP	dsp.ti.com
Clocks and Timers	www.ti.com/clocks
Interface	interface.ti.com
Logic	logic.ti.com
Power Mgmt	power.ti.com
Microcontrollers	microcontroller.ti.com
RFID	www.ti-rfid.com
OMAP Applications Processors	www.ti.com/omap
Wireless Connectivity	www.ti.com/wirelessconnectivity

Applications

Automotive and Transportation	www.ti.com/automotive
Communications and Telecom	www.ti.com/communications
Computers and Peripherals	www.ti.com/computers
Consumer Electronics	www.ti.com/consumer-apps
Energy and Lighting	www.ti.com/energy
Industrial	www.ti.com/industrial
Medical	www.ti.com/medical
Security	www.ti.com/security
Space, Avionics and Defense	www.ti.com/space-avionics-defense
Video and Imaging	www.ti.com/video

TI E2E Community

e2e.ti.com