

TMS470R1VF4B8 16/32-BIT RISC FLASH MICROCONTROLLER

SPNS094C – JUNE 2004 – REVISED AUGUST 2006

- High-Performance Static CMOS Technology
- TMS470R1x 16/32-Bit RISC Core (ARM7TDMI™)
 - 24-MHz System Clock (64-MHz Pipeline Mode)
 - Independent 16/32-Bit Instruction Set
 - Open Architecture With Third-Party Support
 - Built-In Debug Module
- Integrated Memory
 - 256K-Byte Program Flash
 - One Bank With 10 Contiguous Sectors
 - 16K-Byte Static RAM (SRAM)
- Operating Features
 - Core Supply Voltage (V_{CC}): 1.81 V - 2.06 V
 - Core Supply Voltage (V_{CC}): 1.70 V - 2.06 V When Used At or Below 56MHz, 85C Ambient Temp, and 115C Junction Temp
 - I/O Supply Voltage (V_{CCIO}): 3.0 V - 3.6 V
 - Low-Power Modes: STANDBY and HALT
 - Industrial/Automotive Temperature Ranges
- 470+ System Module
 - 32-Bit Address Space Decoding
 - Bus Supervision for Memory/Peripherals
 - Digital Watchdog (DWD) Timer
 - Enhanced Real-Time Interrupt (RTI)
 - System Integrity and Failure Detection
- Zero-Pin Phase-Locked Loop (ZPLL)-Based Clock Module With Prescaler
 - Multiply-by-4 or -8 Internal ZPLL Option
 - ZPLL Bypass Mode
- Six Communication Interfaces:
 - Serial Peripheral Interface (SPI)
 - 255 Programmable Baud Rates
 - Two Serial Communication Interfaces (SCIs)
 - 2^{24} Selectable Baud Rates
 - Asynchronous/Isosynchronous Modes
 - Two Standard CAN Controllers (SCC)
 - 16-Mailbox Capacity
 - Fully Compliant With CAN Protocol, Version 2.0B
 - Multi-Buffered Serial Peripheral Interface (MibSPI)
 - 64-Word Buffer
 - Eight Chip Selects
- High-End Timer (HET)
 - 9 Programmable I/O Channels:
 - 7 High-Resolution Pins
 - High-Resolution Share Feature (XOR)
 - High-End Timer RAM
 - 128-Instruction Capacity
 - External Clock Prescale (ECP) Module
 - Programmable Low-Frequency External Clock (CLK)
 - 16-Channel 10-Bit Multi-Buffered ADC (MibADC)
 - 64-Word FIFO Buffer
 - Single- or Continuous-Conversion Modes
 - 1.55 μ s Minimum Sample and Conversion Time
 - Calibration Mode and Self-Test Features
 - 10 Dedicated General-Purpose I/O (GIO) Pins and 37 Additional Peripheral I/Os
 - Eight External Interrupts
 - Flexible Interrupt Handling
 - Compatible ROM Device (Planned)
 - On-Chip Scan-Base Emulation Logic, IEEE Standard 1149.1[†] (JTAG) Test-Access Port
 - 100-Pin Plastic Low-Profile Quad Flatpack
 - Development System Support Tools Available
 - Code Composer Studio™ Integrated Development Environment (IDE)
 - HET Assembler and Simulator
 - Real-Time In-Circuit Emulation
 - Flash Programming



Please be aware that an important notice concerning availability, standard warranty, and use in critical applications of Texas Instruments semiconductor products and disclaimers thereto appears at the end of this data sheet.

Code Composer Studio is a trademark of Texas Instruments.

ARM7TDMI is a trademark of Advanced RISC Machines Limited (ARM).

All trademarks are the property of their respective owners.

[†] The test-access port is compatible with the IEEE Standard 1149.1-1990, *IEEE Standard Test-Access Port and Boundary Scan Architecture* specification. Boundary scan is not supported on this device.

PRODUCTION DATA information is current as of publication date. Products conform to specifications per the Texas Instruments standard warranty. Production processing does not necessarily include testing of all parameters.



Copyright © 2006, Texas Instruments Incorporated

TMS470R1VF4B8

16/32-BIT RISC FLASH MICROCONTROLLER

SPNS094C – JUNE 2004 – REVISED AUGUST 2006

TMS470R1VF4B8 100-PIN PZ PACKAGE (TOP VIEW)

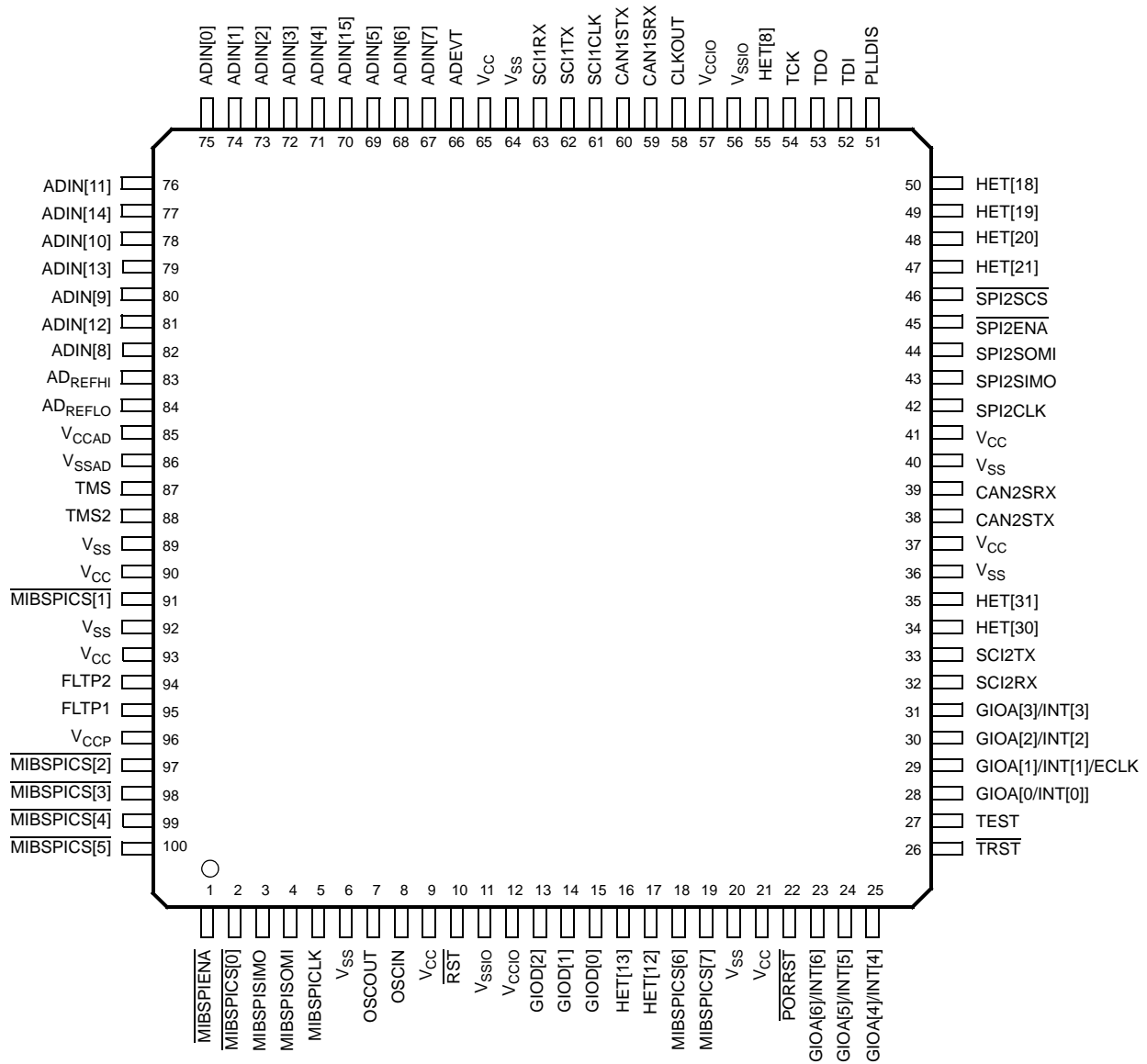

description

The TMS470R1VF4B8[†] device is a member of the Texas Instruments TMS470R1x family of general-purpose 16/32-bit reduced instruction set computer (RISC) microcontrollers. The VF4B8 microcontroller offers high performance utilizing the high-speed ARM7TDMI 16/32-bit RISC central processing unit (CPU), resulting in a high instruction throughput while maintaining greater code efficiency. The ARM7TDMI 16/32-bit RISC CPU views memory as a linear collection of bytes numbered upwards from zero. The TMS470R1VF4B8 utilizes the big-endian format where the most significant byte of a word is stored at the lowest numbered byte and the least significant byte at the highest numbered byte.

High-end embedded control applications demand more performance from their controllers while maintaining low costs. The VF4B8 RISC core architecture offers solutions to these performance and cost demands while maintaining low power consumption.

The VF4B8 device contains the following:

- ARM7TDMI 16/32-Bit RISC CPU
- TMS470R1x system module (SYS) with 470+ enhancements
- 256K-byte flash
- 16K-byte SRAM
- Zero-pin phase-locked loop (ZPLL) clock module
- Digital watchdog (DWD) timer
- Real-time interrupt (RTI) module
- Multi-buffered serial peripheral interface (MibSPI) module
- Serial peripheral interface (SPI) module
- Two serial communications interface (SCI) modules
- Two standard CAN controllers (SCC)
- 10-bit multi-buffered analog-to-digital converter (MibADC), with 16 input channels
- High-end timer (HET) controlling 9 I/Os
- External Clock Prescale (ECP)
- Up to 47 I/O pins

The functions performed by the 470+ system module (SYS) include: address decoding; memory protection; memory and peripherals bus supervision; reset and abort exception management; prioritization for all internal interrupt sources; device clock control; and parallel signature analysis (PSA). The enhanced real-time interrupt (RTI) module on the VF4B8 has the option to be driven by the oscillator clock. The digital watchdog (DWD) is a 25-bit resettable decrementing counter that provides a system reset when the watchdog counter expires. This data sheet includes device-specific information such as memory and peripheral select assignment, interrupt priority, and a device memory map. For a more detailed functional description of the SYS module, see the *TMS470R1x System Module Reference Guide* (literature number SPNU189).

The VF4B8 memory includes general-purpose SRAM supporting single-cycle read/write accesses in byte, half-word, and word modes.

The flash memory on this device is a nonvolatile, electrically erasable and programmable memory implemented with a 32-bit-wide data bus interface. The flash operates with a system clock frequency of up to 24 MHz. When in pipeline mode, the flash operates with a system clock frequency of up to 64 MHz. For more detailed information on the flash, see the flash section of this data sheet and the *TMS470R1x F05 Flash Reference Guide* (literature number SPNU213).

[†] Throughout the remainder of this document, the TMS470R1VF4B8 device shall be referred to by either the full device name or VF4B8.

TMS470R1VF4B8

16/32-BIT RISC FLASH MICROCONTROLLER

SPNS094C – JUNE 2004 – REVISED AUGUST 2006

description (continued)

The VF4B8 device has six communication interfaces: a MibSPI, an SPI, two SCIs, and two SCCs. The MibSPI is a high-speed synchronous serial input/output port that allows a serial bit stream of programmed length to be shifted into and out of the device at a programmed bit-transfer rate. The SPI provides a convenient method of serial interaction for high-speed communications between similar shift-register type devices. The SCI is a full-duplex, serial I/O interface intended for asynchronous communication between the CPU and other peripherals using the standard Non-Return-to-Zero (NRZ) format. The SCC uses a serial, multimaster communication protocol that efficiently supports distributed real-time control with robust communication rates of up to 1 megabit per second (Mbps). The SCC is ideal for applications operating in noisy and harsh environments (e.g., automotive and industrial fields) that require reliable serial communication or multiplexed wiring. For more information on the MibSPI peripheral, see the *TMS470R1x Multi-Buffered Serial Peripheral Interface (MibSPI) Reference Guide* (literature number SPNU217). For more detailed functional information on the SPI, SCI, and SCC peripherals, see the specific reference guides (literature numbers SPNU195, SPNU196, and SPNU197).

The HET is an advanced intelligent timer that provides sophisticated timing functions for real-time applications. The timer is software-controlled, using a reduced instruction set, with a specialized timer micromachine and an attached I/O port. The HET can be used for compare, capture, or general-purpose I/O. It is especially well suited for applications requiring multiple sensor information and drive actuators with complex and accurate time pulses. For more detailed functional information on the HET, see the *TMS470R1x High-End Timer (HET) Reference Guide* (literature number SPNU199). The VF4B8 HET peripheral contains the XOR-share feature. This feature allows two adjacent HET high-resolution channels to be sired together, making it possible to output smaller pulses than a standard HET. For more detailed information on the HET XOR-share feature, see the *TMS470R1x High-End Timer (HET) Reference Guide* (literature number SPNU199).

The VF4B8 device has one 10-bit-resolution, sample-and-hold MibADC. Each of the MibADC channels can be converted individually or can be grouped by software for sequential conversion sequences. There are three separate groupings, two of which can be triggered by an external event. Each sequence can be converted once when triggered or configured for continuous conversion mode. For more detailed functional information on the MibADC, see the *TMS470R1x Multi-Buffered Analog-to-Digital Converter (MibADC) Reference Guide* (literature number SPNU206).

The zero-pin phase-locked loop (ZPLL) clock module contains a phase-locked loop, a clock-monitor circuit, a clock-enable circuit, and a prescaler (with prescale values of 1–8). The function of the ZPLL is to multiply the external frequency reference to a higher frequency for internal use. The ZPLL provides ACLK[†] to the system (SYS) module. The SYS module subsequently provides system clock (SYSCLK), real-time interrupt clock (RTICLK), CPU clock (MCLK), and peripheral interface clock (ICLK) to all other VF4B8 device modules. For more detailed functional information on the ZPLL, see the *TMS470R1x Zero-Pin Phase-Locked Loop (ZPLL) Clock Module Reference Guide* (literature number SPNU212).

The VF4B8 device also has an external clock prescaler (ECP) module that, when enabled, outputs a continuous external clock (ECLK) on a specified GIO pin. The ECLK frequency is a user-programmable ratio of the peripheral interface clock (ICLK) frequency. For more detailed functional information on the ECP, see the *TMS470R1x External Clock Prescaler (ECP) Reference Guide* (literature number SPNU202).

[†] ACLK should not be confused with the MibADC internal clock, ADCLK. ACLK is the continuous system clock from an external resonator/crystal reference.

TMS470R1VF4B8

16/32-BIT RISC FLASH MICROCONTROLLER

SPNS094C – JUNE 2004 – REVISED AUGUST 2006

device characteristics

The VF4B8 device is a derivative of the F05 system emulation device SE470R1VB8AD. Table 1 identifies all the characteristics of the VF4B8 device except the SYSTEM and CPU, which are generic. The COMMENTS column aids the user in software-programming and references device-specific information.

Table 1. Device Characteristics

CHARACTERISTICS	DEVICE DESCRIPTION TMS470R1VF4B8	COMMENTS FOR VF4B8
MEMORY		
For the number of memory selects on this device, see the Memory Selection Assignment table (Table 2).		
INTERNAL MEMORY	Pipeline/Non-Pipeline	Flash is pipeline-capable
	256K-Byte flash 16K-Byte SRAM	The VF4B8 RAM is implemented in one 16K array selected by two memory-select signals (see the Memory Selection Assignment table, Table 2).
PERIPHERALS		
For the device-specific interrupt priority configurations, see the Interrupt Priority Table (Table 4). And for the 1K peripheral address ranges and their peripheral selects, see the Peripherals, System Module, and Flash Base Addresses table (Table 3).		
CLOCK	ZPLL	Zero-pin PLL has no external loop filter pins.
GENERAL-PURPOSE I/Os	10 I/O	Port A has seven (7) external pins, and Port D has three (3) external pins.
ECP	YES	
SCI	1 (2-pin) 1 (3-pin)	
CAN (HECC and/or SCC)	2 SCC	Standard CAN controllers
SPI (5-pin, 4-pin or 3-pin)	1 (5-pin)	
MibSPI	1 (12-pin)	Eight chip selects Master mode only
HET with XOR Share	9 I/O	The high-resolution (HR) SHARE feature allows even HR pins to share the next higher odd HR pin structures. This HR sharing is independent of whether or not the odd pin is available externally. If an odd pin is available externally and <i>shared</i> , then the odd pin can only be used as a general-purpose I/O. For more information on HR SHARE, see the <i>TMS470R1x High-End Timer (HET) Reference Guide</i> (literature number SPNU199).
HET RAM	64-Instruction Capacity	
MibADC	10-bit, 16-channel 64-word FIFO	Both the logic and registers for a full 16-channel MibADC are present.
CORE VOLTAGE	1.81V – 2.06V	
	1.70 – 2.06V	When operating at or below 56MHz, 85C ambient temperature, and 115C junction temperature.
I/O VOLTAGE	3.0V – 3.6V	
PINS	100	
PACKAGES	PZ	

TMS470R1VF4B8

16/32-BIT RISC FLASH MICROCONTROLLER

SPNS094C – JUNE 2004 – REVISED AUGUST 2006

functional block diagram

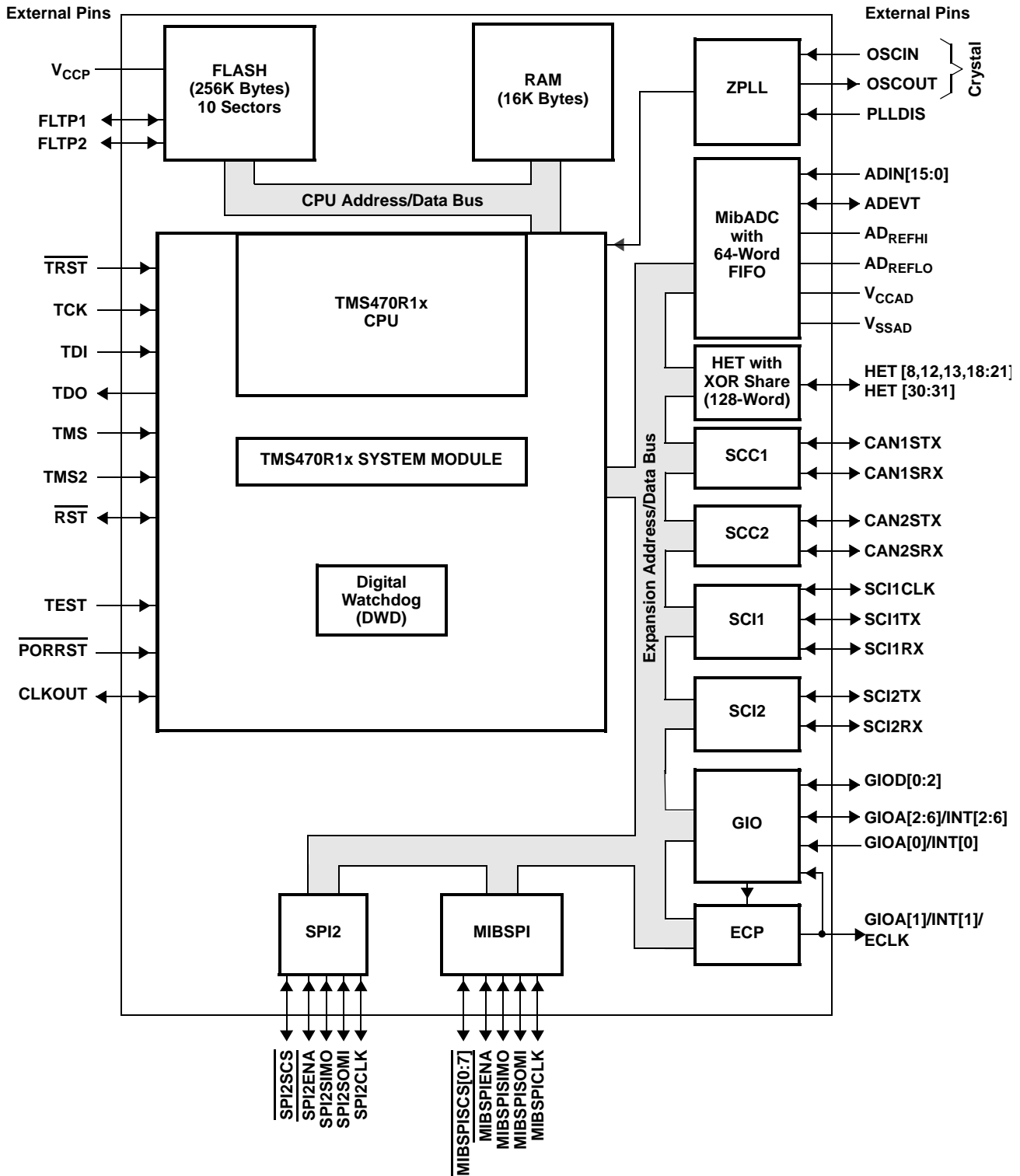

TMS470R1VF4B8

16/32-BIT RISC FLASH MICROCONTROLLER

SPNS094C – JUNE 2004 – REVISED AUGUST 2006

Terminal Functions

TERMINAL NAME	PIN NO.	INPUT VOLTAGE†‡	OUTPUT CURRENT†‡	INTERNAL PULLUP/ PULLDOWN§	DESCRIPTION	
HIGH-END TIMER (HET)						
HET[8]	55	3.3-V	2mA	IPD (20 μ A)	Timer input capture or output compare. These pins can be programmed as general-purpose input/output (GIO) pins. HET[8,12,13,18,19,20,21] are high-resolution pins, and HET[30:31] are standard-resolution pins. The high-resolution (HR) SHARE feature allows even HR pins to share the next higher odd HR pin structures. This HR sharing is independent of whether or not the odd pin is available externally. If an odd pin is available externally and <i>shared</i> , then the odd pin can only be used as a general-purpose I/O. For more information on HR SHARE, see the <i>TMS470R1x High-End Timer (HET) Reference Guide</i> (literature number SPNU199).	
HET[12]	17					
HET[13]	16					
HET[18]	50					
HET[19]	49					
HET[20]	48					
HET[21]	47					
HET[30]	34					
HET[31]	35					
STANDARD CAN CONTROLLER 1 (SCC1)						
CAN1SRX	59	3.3-V	2mA		SCC1 receive pin or GIO pin	
CAN1STX	60			IPU (20 μ A)	SCC1 transmit pin or GIO pin	
STANDARD CAN CONTROLLER 2 (SCC2)						
CAN2SRX	39	3.3-V	2mA		SCC2 receive pin or GIO pin	
CAN2STX	38			IPU (20 μ A)	SCC2 transmit pin or GIO pin	
GENERAL-PURPOSE I/O (GIO)						
GIOA[0]/INT[0]	28	3.3-V	4mA	IPD (20 μ A)	General-purpose input/output pins. GIOA[0]/INT[0] is an input-only pin. GIOA[7:0]/INT[7:0] are interrupt-capable pins. If pins GIOA[6:2] are not externally pulled up or down, they need to be driven as output LOW for reduced power consumption in low power mode.	
GIOA[1]/INT[1]/ECLK	29					
GIOA[2]/INT[2]	30					
GIOA[3]/INT[3]	31		2mA			GIOA[1]/INT[1]/ECLK pin is multiplexed with the external clock-out function of the external clock prescale (ECP) module.
GIOA[4]/INT[4]	25					
GIOA[5]/INT[5]	24					
GIOA[6]/INT[6]	23					
GIOD[0]	15	3.3-V	2mA		General-purpose input/output pins. If pins GIOD[2:0] are not externally pulled up or down, they need to be driven as output LOW for reduced power consumption in low power mode.	
GIOD[1]	14					
GIOD[2]	13					

† PWR = power, GND = ground, REF = reference voltage, NC = no connect

‡ All I/O pins, except RST, are configured as inputs while PORRST is low and immediately after PORRST goes high.

§ IPD = internal pulldown, IPU = internal pullup (all internal pullups and pulldowns are active on input pins, independent of the PORRST state.)

TMS470R1VF4B8

16/32-BIT RISC FLASH MICROCONTROLLER

SPNS094C – JUNE 2004 – REVISED AUGUST 2006

Terminal Functions (Continued)

TERMINAL NAME	PIN NO.	INPUT VOLTAGE†‡	OUTPUT CURRENT†‡	INTERNAL PULLUP/PULLDOWN§	DESCRIPTION
MULTI-BUFFERED ANALOG-TO-DIGITAL CONVERTER (MibADC)					
ADEVT	66	3.3-V	2mA	IPD (20 μ A)	MibADC event input. Can be programmed as a GIO pin.
ADIN[0]	75		MibADC analog input pins		
ADIN[1]	74				
ADIN[2]	73				
ADIN[3]	72				
ADIN[4]	71				
ADIN[5]	69				
ADIN[6]	68				
ADIN[7]	67				
ADIN[8]	82				
ADIN[9]	80				
ADIN[10]	78				
ADIN[11]	76				
ADIN[12]	81				
ADIN[13]	79				
ADIN[14]	77				
ADIN[15]	70				
AD _{REFHI}	83	3.3-V REF			MibADC module high-voltage reference input
AD _{REFLO}	84	GND REF			MibADC module low-voltage reference input
V _{CCAD}	85	3.3-V PWR			MibADC analog supply voltage
V _{SSAD}	86	GND			MibADC analog ground reference
SERIAL PERIPHERAL INTERFACE 2 (SPI2)					
SPI2CLK	42	3.3-V	4mA	IPD (20 μ A)	SPI2 clock. SPI1CLK can be programmed as a GIO pin.
SPI2ENA	45		2mA		SPI2 chip enable. Can be programmed as a GIO pin.
SPI2SCS	46				SPI2 slave chip select. Can be programmed as a GIO pin.
SPI2SIMO	43		4mA		SPI2 data stream. Slave in/master out. Can be programmed as a GIO pin.
SPI2SOMI	44		4mA		SPI2data stream. Slave out/master in. Can be programmed as a GIO pin.
MULTI-BUFFERED SERIAL PERIPHERAL INTERFACE (MIBSPI)					
MIBSPICLK	5	3.3-V	4mA	IPD (20 μ A)	MibSPI clock. SPI1CLK can be programmed as a GIO pin.
MIBSPISIMO	3				MibSPI data stream. Slave in/master out. Can be programmed as a GIO pin.
MIBSPISOMI	4				MibSPI data stream. Slave out/master in. Can be programmed as a GIO pin.
MIBSPIENA	1		2mA		MibSPI chip enable. Can be programmed as a GIO pin.

† PWR = power, GND = ground, REF = reference voltage, NC = no connect

‡ All I/O pins, except RST, are configured as inputs while PORRST is low and immediately after PORRST goes high.

§ IPD = internal pulldown, IPU = internal pullup (all internal pullups and pulldowns are active on input pins, independent of the PORRST state.)



TMS470R1VF4B8

16/32-BIT RISC FLASH MICROCONTROLLER

SPNS094C – JUNE 2004 – REVISED AUGUST 2006

Terminal Functions (Continued)

TERMINAL NAME	PIN NO.	INPUT VOLTAGE†‡	OUTPUT CURRENT†‡	INTERNAL PULLUP/ PULLDOWN§	DESCRIPTION
MULTI-BUFFERED SERIAL PERIPHERAL INTERFACE (MIBSPI) (CONTINUED)					
MIBSPISCS[0]	2	3.3-V	2mA		MibSPI slave chip select. Can be programmed as a GIO pin. If pins MIBSPISCS[4:0] are not externally pulled up or down, they need to be driven as output LOW for reduced power consumption in low power mode.
MIBSPISCS[1]	91				
MIBSPISCS[2]	97				
MIBSPISCS[3]	98				
MIBSPISCS[4]	99				MibSPI slave chip select. If pins MIBSPISCS[7:5] are not externally pulled up or down, they need to be driven as output LOW for reduced power consumption in low power mode.
MIBSPISCS[5]	100				
MIBSPISCS[6]	18				
MIBSPISCS[7]	19				
ZERO-PIN PHASE-LOCKED LOOP (ZPLL)					
OSCIN	8	1.8-V			Crystal connection pin or external clock input
OSCOU	7		1.8-V O		External crystal connection pin
PLLDIS	51	3.3-V		IPD (100 μ A)	Enable/disable the ZPLL. The ZPLL can be bypassed and the oscillator becomes the system clock. If not in bypass mode, TI recommends that this pin be connected to ground or pulled down to ground by an external resistor.
SERIAL COMMUNICATIONS INTERFACE 1 (SCI1)					
SCI1CLK	61	3.3-V	2mA	IPD (20 μ A)	SCI1 clock. SCI1CLK can be programmed as a GIO pin.
SCI1RX	63			IPU (20 μ A)	SCI1 data receive. SCI1RX can be programmed as a GIO pin.
SCI1TX	62			IPU (20 μ A)	SCI1 data transmit. SCI1TX can be programmed as a GIO pin.
SERIAL COMMUNICATIONS INTERFACE 2 (SCI2)					
SCI2RX	32	3.3-V	2mA	IPU (20 μ A)	SCI2 data receive. SCI2RX can be programmed as a GIO pin.
SCI2TX	33				SCI2 data transmit. SCI2TX can be programmed as a GIO pin.
SYSTEM MODULE (SYS)					
CLKOUT	58	3.3-V	8mA	IPD (20 μ A)	Bidirectional pin. CLKOUT can be programmed as a GIO pin or the output of SYSClk, ICLK, or MCLK.
PORRST	22	3.3-V		IPD (20 μ A)	Input master chip power-up reset. External V_{CC} monitor circuitry must assert a power-on reset.
RST	10	3.3-V	4mA	IPU (100 μ A)	Bidirectional reset. The internal circuitry can assert a reset, and an external system reset can assert a device reset. On this pin, the output buffer is implemented as an open drain (drives low only). To ensure an external reset is not arbitrarily generated, TI recommends that an external pullup resistor be connected to this pin.

† PWR = power, GND = ground, REF = reference voltage, NC = no connect

‡ All I/O pins, except RST, are configured as inputs while PORRST is low and immediately after PORRST goes high.

§ IPD = internal pulldown, IPU = internal pullup (all internal pullups and pulldowns are active on input pins, independent of the PORRST state.)

TMS470R1VF4B8

16/32-BIT RISC FLASH MICROCONTROLLER

SPNS094C – JUNE 2004 – REVISED AUGUST 2006

Terminal Functions (Continued)

TERMINAL NAME	PIN NO.	INPUT VOLTAGE†‡	OUTPUT CURRENT†‡	INTERNAL PULLUP/PULLDOWN§	DESCRIPTION
TEST/DEBUG (T/D)					
TCK	54	3.3-V		IPD (20 μ A)	Test clock. TCK controls the test hardware (JTAG).
TDI	52			IPI (20 μ A)	Test data in. TDI inputs serial data to the test instruction register, test data register, and programmable test address (JTAG).
TDO	53		8mA	IPD (20 μ A)	Test data out. TDO outputs serial data from the test instruction register, test data register, identification register, and programmable test address (JTAG).
TEST	27	3.3-V		IPD (100 μ A)	Test enable. Reserved for internal use only. TI recommends that this pin be connected to ground or pulled down to ground by an external resistor.
TMS	87			IPI (100 μ A)	Serial input for controlling the state of the CPU test access port (TAP) controller (JTAG).
TMS2	88		4mA	IPI (100 μ A)	Serial input for controlling the second TAP. TI recommends that this pin be connected to V_{CCIO} or pulled up to V_{CCIO} by an external resistor.
$\overline{\text{TRST}}$	26			IPD (100 μ A)	Test hardware reset to TAP1 and TAP2. IEEE Standard 1149-1 (JTAG) Boundary-Scan Logic. TI recommends that this pin be pulled down to ground by an external resistor.
FLASH					
FLTP1	95	NC			Flash test pad 1. For proper operation, this pin must not be connected [no connect (NC)].
FLTP2	94	NC			Flash test pad 2. For proper operation, this pin must not be connected [no connect (NC)].
V_{CCP}	96	3.3-V PWR			Flash external pump voltage (3.3 V)
SUPPLY VOLTAGE CORE (1.8 V)					
V_{CC}	9	1.8-V PWR			Core logic supply voltage
	21				
	37				
	41				
	65				
	90				
	93				
SUPPLY VOLTAGE DIGITAL I/O (3.3 V)					
V_{CCIO}	12	3.3-V PWR			Digital I/O supply voltage
	57				
SUPPLY GROUND CORE					
V_{SS}	6	GND			Core supply ground reference
	20				
	36				
	40				
	64				
	89				
	92				
SUPPLY GROUND DIGITAL I/O					
V_{SSIO}	11	GND			Digital I/O supply ground reference
	56				

† PWR = power, GND = ground, REF = reference voltage, NC = no connect

‡ All I/O pins, except $\overline{\text{RST}}$, are configured as inputs while $\overline{\text{PORRST}}$ is low and immediately after $\overline{\text{PORRST}}$ goes high.

§ IPD = internal pulldown, IPI = internal pullup (all internal pullups and pulldowns are active on input pins, independent of the $\overline{\text{PORRST}}$ state.)



VF4B8 DEVICE-SPECIFIC INFORMATION

memory

Figure 1 shows the memory map of the VF4xB device.

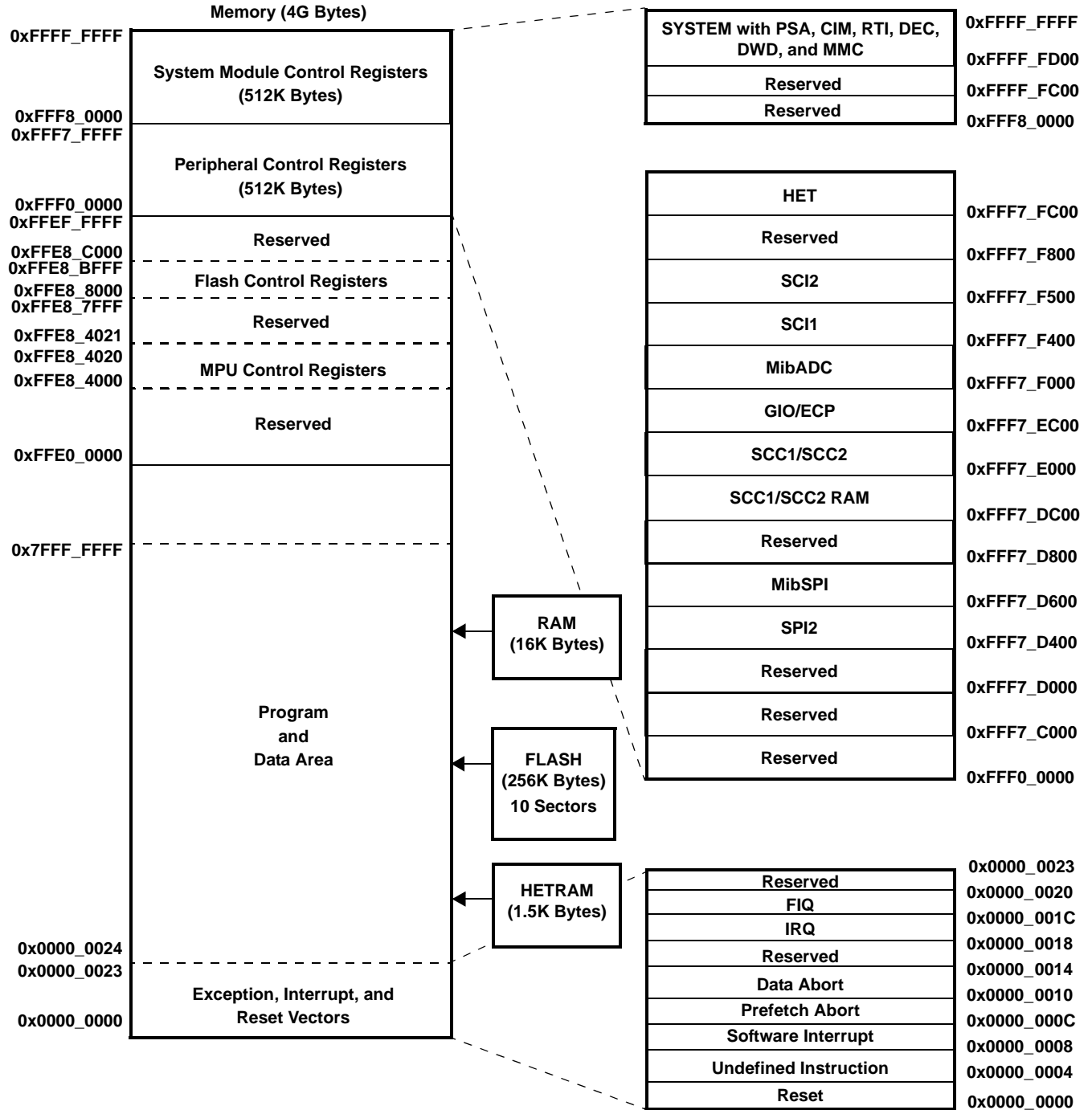

NOTES: A. Memory addresses are configurable by the system (SYS) module within the range of 0x0000_0000 to 0xFFE0_0000.
 B. The CPU registers are not a part of the memory map.

Figure 1. TMS470R1VF4B8 Memory Map

TMS470R1VF4B8

16/32-BIT RISC FLASH MICROCONTROLLER

SPNS094C – JUNE 2004 – REVISED AUGUST 2006

memory selects

Memory selects allow the user to address memory arrays (i.e., flash, RAM, and HET RAM) at user-defined addresses. Each memory select has its own set (low and high) of memory base address registers (MFBAHRx and MFBALRx) that, together, define the array's starting (base) address, size, and protection.

The base address of each memory select is configurable to any memory address boundary that is a multiple of the decoded block size. The decoded block size for the flash memory on this device is 0x00200000. For more information on how to control and configure these memory select registers, see the bus structure and memory sections of the *TMS470R1x System Module Reference Guide* (literature number SPNU189).

For the memory selection assignments and the memory selected, see Table 2.

Table 2. TMS470R1VF4B8 Memory Selection Assignment

MEMORY SELECT	MEMORY SELECTED (ALL INTERNAL)	MEMORY SIZE	MPU	MEMORY BASE ADDRESS REGISTER	STATIC MEM CTL REGISTER
0 (fine)	FLASH	256K	NO	MFBAHR0 and MFBALR0	
1 (fine)	FLASH		NO	MFBAHR1 and MFBALR1	
2 (fine)	RAM	16K [†]	YES	MFBAHR2 and MFBALR2	
3 (fine)	RAM		YES	MFBAHR3 and MFBALR3	
4 (fine)	HET RAM	1.5K	NO	MFBAHR4 and MFBALR4	SMCR1
1 (coarse)	MibSPI RAM	0.5K	NO	MCBAHR1 and MCBALR1	SMCR4

[†] The starting addresses for both RAM memory-select signals *cannot* be offset from each other by a multiple of the user-defined block size in the memory-base address register.

RAM

The VF4B8 device contains 16K-bytes of internal static RAM configurable by the SYS module to be addressed within the range of 0x0000_0000 to 0xFFE0_0000. This VF4B8 RAM is implemented in one 16K array selected by two memory-select signals. This VF4B8 configuration imposes an additional constraint on the memory map for RAM; the starting addresses for both RAM memory selects *cannot* be offset from each other by the multiples of the size of the physical RAM (i.e., 16K for the VF4B8 device). The VF4B8 RAM is addressed through memory selects 2 and 3.

The RAM can be protected by the memory protection unit (MPU) portion of the SYS module, allowing the user finer blocks of memory protection than is allowed by the memory selects. The MPU is ideal for protecting an operating system while allowing access to the current task. For more detailed information on the MPU portion of the SYS module and memory protection, see the memory section of the *TMS470R1x System Module Reference Guide* (literature number SPNU189).

F05 flash

The F05 flash memory is a nonvolatile electrically erasable and programmable memory implemented with a 32-bit-wide data bus interface. The F05 flash has an external state machine for programming and erase functions. See the *flash read* and *flash program and erase* sections below.

flash protection keys

The VF4B8 device provides flash protection keys. These four 32-bit protection keys prevent program/erase/compaction operations from occurring until after the four protection keys have been matched by the CPU loading the correct user keys into the FMPKEY control register. The protection keys on the VF4B8 are located in the last 4 words of the first 16K sector. For more detailed information on the flash protection keys and the FMPKEY control register, see the Optional Quadruple Protection Keys and Programming the Protection Keys portions of the *TMS470R1x F05 Flash Reference Guide* (literature number SPNU213).

FLASH read

The VF4B8 flash memory is configurable by the SYS module to be addressed within the range of 0x0000_0000 to 0xFFE0_0000. The flash is addressed through memory selects 0 and 1.

Note: The flash external pump voltage (V_{CCP}) is required for all operations (program, erase, and read).

flash pipeline mode

When in pipeline mode, the flash operates with a system clock frequency of up to 64 MHz, versus a system clock frequency of 24 MHz in normal mode. Flash in pipeline mode is capable of accessing 64-bit words and provides two 32-bit pipelined words to the CPU. Also, in pipeline mode the flash can be read with no wait states when memory addresses are contiguous (after the initial 1- or 2-wait-state reads).

Note: After a system reset, pipeline mode is disabled (ENPIPE bit [FMREGOPT.0] is a "0"). In other words, the VF4B8 device powers up and comes out of reset in non-pipeline mode. Furthermore, setting the flash configuration mode bit (GBLCTRL.4) will override pipeline mode.

flash program and erase

The VF4B8 device flash contains one 256K-byte memory array (or bank), and consists of ten sectors. These ten sectors are sized as follows:

SECTOR NO.	SEGMENT	LOW ADDRESS	HIGH ADDRESS	MEMORY ARRAY (OR BANK)
0	16K Bytes	0x0000_0000	0x0000_3FFF	BANK0 (256K Bytes)
1	16K Bytes	0x0000_4000	0x0000_7FFF	
2	32K Bytes	0x0000_8000	0x0000_FFFF	
3	32K Bytes	0x0001_0000	0x0001_7FFF	
4	32K Bytes	0x0001_8000	0x0001_FFFF	
5	32K Bytes	0x0002_0000	0x0002_7FFF	
6	32K Bytes	0x0002_8000	0x0002_FFFF	
7	32K Bytes	0x0003_0000	0x0003_7FFF	
8	16K Bytes	0x0003_8000	0x0003_BFFF	
9	16K Bytes	0x0003_C000	0x0003_FFFF	

The minimum size for an erase operation is one sector. The maximum size for a program operation is one 16-bit word.

Note: The flash external pump voltage (V_{CCP}) is required for all operations (program, erase, and read).

Execution can occur from one bank while programming/erasing any or all sectors of another bank. However, execution cannot occur from any sector within a bank that is being programmed or erased.

For more detailed information on flash program and erase operations, see the *TMS470R1x F05 Flash Reference Guide* (literature number SPNU213).

HET RAM

The VF4B8 device contains HET RAM. The HET RAM has a 128-instruction capability. The HET RAM is configurable by the SYS module to be addressed within the range of 0x0000_0000 to 0xFFE0_0000. The HET RAM is addressed through memory select 4.

TMS470R1VF4B8

16/32-BIT RISC FLASH MICROCONTROLLER

SPNS094C – JUNE 2004 – REVISED AUGUST 2006

peripheral selects and base addresses

The VF4B8 device uses ten of the sixteen peripheral selects to decode the base addresses of the peripherals. These peripheral selects are fixed and transparent to the user since they are part of the decoding scheme used by the SYS module.

Control registers for the peripherals, SYS module, and flash begin at the base addresses shown in Table 3.

Table 3. VF4B8 Peripherals, System Module, and Flash Base Addresses

CONNECTING MODULE	ADDRESS RANGE		PERIPHERAL SELECTS
	BASE ADDRESS	ENDING ADDRESS	
SYSTEM	0xFFFF_FD00	0xFFFF_FFFF	N/A
RESERVED	0xFFF8_0000	0xFFFF_FCFF	N/A
RESERVED	0xFFF7_FE00	0xFFF7_FFFF	PS[0]
RESERVED	0xFFF7_FD00	0xFFF7_FDFF	
HET	0xFFF7_FC00	0xFFF7_FCFE	PS[1]
RESERVED	0xFFF7_F900	0xFFF7_FBFF	
RESERVED	0xFFF7_F800	0xFFF7_F8FF	PS[2]
RESERVED	0xFFF7_F600	0xFFF7_F7FF	
SC12	0xFFF7_F500	0xFFF7_F5FF	PS[3]
SC11	0xFFF7_F400	0xFFF7_F4FF	
RESERVED	0xFFF7_F100	0xFFF7_F3FF	PS[4]
MIBADC	0xFFF7_F000	0xFFF7_F0FF	
ECP	0xFFF7_EF00	0xFFF7_EFFF	PS[5]
RESERVED	0xFFF7_ED00	0xFFF7_EEFF	
GIO	0xFFF7_EC00	0xFFF7_ECFE	PS[6]
RESERVED	0xFFF7_EA00	0xFFF7_EBFF	
RESERVED	0xFFF7_E800	0xFFF7_E9FF	PS[7]
RESERVED	0xFFF7_E600	0xFFF7_E7FF	
RESERVED	0xFFF7_E400	0xFFF7_E5FF	PS[8]
RESERVED	0xFFF7_E300	0xFFF7_E3FF	
SCC2	0xFFF7_E200	0xFFF7_E2FF	PS[9]
RESERVED	0xFFF7_E100	0xFFF7_E1FF	
SCC1	0xFFF7_E000	0xFFF7_E0FF	PS[10]
RESERVED	0xFFF7_DF00	0xFFF7_DFFF	
SCC2 RAM	0xFFF7_DE00	0xFFF7_DEFF	PS[11]
RESERVED	0xFFF7_DD00	0xFFF7_DDFF	
SCC1 RAM	0xFFF7_DC00	0xFFF7_DCFF	PS[12]
RESERVED	0xFFF7_D800	0xFFF7_DBFF	
RESERVED	0xFFF7_D700	0xFFF7_D7FF	PS[13]
MIBSPI	0xFFF7_D600	0xFFF7_D6FF	
RESERVED	0xFFF7_D500	0xFFF7_D5FF	PS[14]
SPI2	0xFFF7_D400	0xFFF7_D4FF	
RESERVED	0xFFF7_D000	0xFFF7_D3FF	PS[15]
RESERVED	0xFFF7_CC00	0xFFF7_CFFF	
RESERVED	0xFFF7_C800	0xFFF7_CBFF	N/A
RESERVED	0xFFF7_C400	0xFFF7_C7FF	
RESERVED	0xFFF7_C000	0xFFF7_C3FF	N/A
RESERVED	0xFFF0_0000	0xFFF7_BFFF	
FLASH CONTROL REGISTERS	0xFFE8_8000	0xFFE8_807F	N/A
MPU CONTROL REGISTERS	0xFFE8_4000	0xFFE8_4023	N/A

interrupt priority (CIM)

The interrupt manager (CIM) portion of the SYS module manages the interrupt requests from the device modules (i.e, MibSPI, SPI2, SCI1, SCI2, SCC1, SCC2, etc.)

The CIM request channels are maskable so that individual channels can be selectively disabled. All interrupt requests can be programmed in the CIM to be of either type:

- Fast interrupt request (FIQ)
- Normal interrupt request (IRQ)

The CIM prioritizes interrupts. The precedences of request channels decrease with ascending channel order in the CIM (0 [highest] and 31 [lowest] priority). For channel priorities, and their associated modules, see Table 4.

Table 4. Interrupt Priority (CIM)

MODULES	INTERRUPT SOURCES	DEFAULT CIM INTERRUPT LEVEL/CHANNEL
Reserved		0
RTI	COMP2 interrupt	1
RTI	COMP1 interrupt	2
RTI	TAP interrupt	3
SPI2	SPI2 end-transfer/overrun	4
GIO	GIO interrupt A	5
Reserved		6
HET	HET interrupt 1	7
MibSPI	MibSPI interrupt A	8
SCI1/SCI2	SCI1 or SCI2 error interrupt	9
SCI1	SCI1 receive interrupt	10
Reserved		11
Reserved		12
SCC2	SCC2 interrupt A	13
SCC1	SCC1 interrupt A	14
MibSPI	MibSPI interrupt B	15
MibADC	MibADC end event conversion	16
SCI2	SCI2 receive interrupt	17
Reserved		18
Reserved		19
SCI1	SCI1 transmit interrupt	20
System	SW interrupt (SSI)	21
Reserved		22
HET	HET interrupt 2	23
SCC2	SCC2 interrupt B	24
SCC1	SCC1 interrupt B	25
SCI2	SCI2 transmit interrupt	26
MibADC	MibADC end Group 1 conversion	27
Reserved		28
GIO	GIO interrupt B	29
MibADC	MibADC end Group 2 conversion	30
Reserved		31

For more detailed functional information on the CIM, see the *TMS470R1x System Module Reference Guide* (literature number SPNU189).

TMS470R1VF4B8

16/32-BIT RISC FLASH MICROCONTROLLER

SPNS094C – JUNE 2004 – REVISED AUGUST 2006

MibADC

The multi-buffered analog-to-digital converter (MibADC) accepts an analog signal and converts the signal to a 10-bit digital value.

The VF4B8 MibADC module can function in two modes: compatibility mode, where its programmer's model is compatible with the TMS470R1x ADC module and its digital results are stored in digital result registers; or in buffered mode, where the digital result registers are replaced with three FIFO buffers, one for each conversion group [event, group1 (G1), and group2 (G2)]. In buffered mode, the MibADC buffers can be serviced by interrupts.

MibADC event trigger enhancements

The MibADC includes two major enhancements over the event-triggering capability of the TMS470R1x ADC.

- Both group 1 and the event group can be configured for event-triggered operation, providing up to two event-triggered groups.
- The trigger source and polarity can be selected individually for both group 1 and the event group from the options identified in Table 5.

Table 5. MibADC Event Hookup Configuration

EVENT #	SOURCE SELECT BITS FOR G1 OR EVENT (G1SRC[1:0] or EVSRC[1:0])	SIGNAL PIN NAME
EVENT1	00	ADEVT
EVENT2	01	HET18
EVENT3	10	HET19
EVENT4	11	Reserved

For group 1, these event-triggered selections are configured via the group 1 source select bits (G1SRC[1:0]) in the AD event source register (ADEVTSRC.[5:4]). For the event group, these event-triggered selections are configured via the event group source select bits (EVSRC[1:0]) in the AD event source register (ADEVTSRC.[1:0]).

For more detailed functional information on the MibADC, see the *TMS470R1x Multi-Buffered Analog-to-Digital Converter (MibADC) Reference Guide* (literature number SPNU206).

MibSPI

The MibSPI is a high-speed synchronous serial input/output port that allows a serial bit stream of programmed length (one to 16 bits) to be shifted into and out of the device at a programmed bit-transfer rate. The MibSPI is normally used for communication between the microcontroller and external peripherals or another microcontroller. Typical applications include interface to external I/O or peripheral expansion via devices such as shift registers, display drivers, and analog-to-digital converters.

Slave mode is not supported by the MibSPI on this device.

Table 6 shows the trigger sources for MibSPI.

Table 6. MibSPI Event Hookup Configuration

EVENT #	SOURCE SELECT BITS FOR TRIGGER SOURCES (TRGSRC[3:0])	SIGNAL PIN NAME
EVENT0	0001	GIOA[0]
EVENT1	0010	GIOA[2]
EVENT2	0011	GIOA[3]
EVENT3	0100	GIOA[4]
EVENT4	0101	HET[20]
EVENT5	0110	HET[21]
EVENT6	0111	HET[22]
EVENT7	1000	HET[23]
EVENT8	1001	HET[25]
EVENT9	1010	HET[26]
EVENT10	1011	HET[27]
EVENT11	1100	ADEVT
EVENT12	1101	N/C
EVENT13	1110	N/C
EVENT14	1111	Internal Tick Counter

TMS470R1VF4B8

16/32-BIT RISC FLASH MICROCONTROLLER

SPNS094C – JUNE 2004 – REVISED AUGUST 2006

development system support

Texas Instruments provides extensive hardware and software development support tools for the TMS470R1x family. These support tools include:

- Code Composer Studio™ Integrated Development Environment (IDE)
 - Fully integrated suite of software development tools
 - Includes Compiler/Assembler/Linker, Debugger, and Simulator
 - Supports Real-Time analysis, data visualization, and open API
- Optimizing C compiler
 - Supports high-level language programming
 - Full implementation of the standard ANSI C language
 - Powerful optimizer that improves code-execution speed and reduces code size
 - Extensive run-time support library included
 - TMS470R1x control registers easily accessible from the C program
 - Interfaces C functions and assembly functions easily
 - Establishes comprehensive, easy-to-use tool set for the development of high-performance microcontroller applications in C/C++
- Assembly language tools (assembler and linker)
 - Provides extensive macro capability
 - Allows high-speed operation
 - Allows extensive control of the assembly process using assembler directives
 - Automatically resolves memory references as C and assembly modules are combined
- TMS470R1x CPU Simulator
 - Provides capability to simulate CPU operation without emulation hardware
 - Allows inspection and modifications of memory locations
 - Allows debugging programs in C or assembly language
- XDS emulation communication kit
 - Allows high-speed JTAG communication to the TMS470R1x emulator or target board

For more information on pricing and availability, contact the nearest TI field sales office or authorized distributor.



documentation support

Extensive documentation supports all of the TMS470 microcontroller family generation of devices. The types of documentation available include: data sheets with design specifications; complete user's guides for all devices and development support tools; and hardware and software applications. Useful reference documentation includes:

- Users Guides
 - *TMS470R1x 32-Bit RISC Microcontroller Family User's Guide* (literature number SPNU134)
 - *TMS470R1x C/C++ Compiler User's Guide* (literature number SPNU151)
 - *TMS470R1x Code Generation Tools Getting Started Guide* (literature number SPNU117)
 - *TMS470R1x C Source Debugger User's Guide* (literature number SPNU124)
 - *TMS470R1x Assembly Language Tools User's Guide* (literature number SPNU118)
 - *TMS470R1x System Module Reference Guide* (literature number SPNU189)
 - *TMS470R1x Serial Peripheral Interface (SPI) Reference Guide* (literature number SPNU195)
 - *TMS470R1x Serial Communication Interface (SCI) Reference Guide* (literature number SPNU196)
 - *TMS470R1x Controller Area Network (CAN) Reference Guide* (literature number SPNU197)
 - *TMS470R1x High-End Timer (HET) Reference Guide* (literature number SPNU199)
 - *TMS470R1x External Clock Prescale (ECP) Reference Guide* (literature number SPNU202)
 - *TMS470R1x Multi-Buffered Analog-to-Digital Converter (MibADC) Reference Guide* (literature number SPNU206)
 - *TMS470R1x Zero-Pin Phase-Locked Loop (ZPLL) Clock Module Reference Guide* (literature number SPNU212)
 - *TMS470R1x F05 Flash Reference Guide* (literature number SPNU213)
 - *TMS470R1x Multi-Buffered Serial Peripheral Interface (MibSPI) Reference Guide* (literature number SPNU217)
- Application Reports:
 - *F05/C05 Power Up Reset and Power Sequencing Requirements* (literature number SPNA009)

TMS470R1VF4B8 16/32-BIT RISC FLASH MICROCONTROLLER

SPNS094C – JUNE 2004 – REVISED AUGUST 2006

device numbering conventions

Figure 2 illustrates the numbering and symbol nomenclature for the TMS470R1x family.

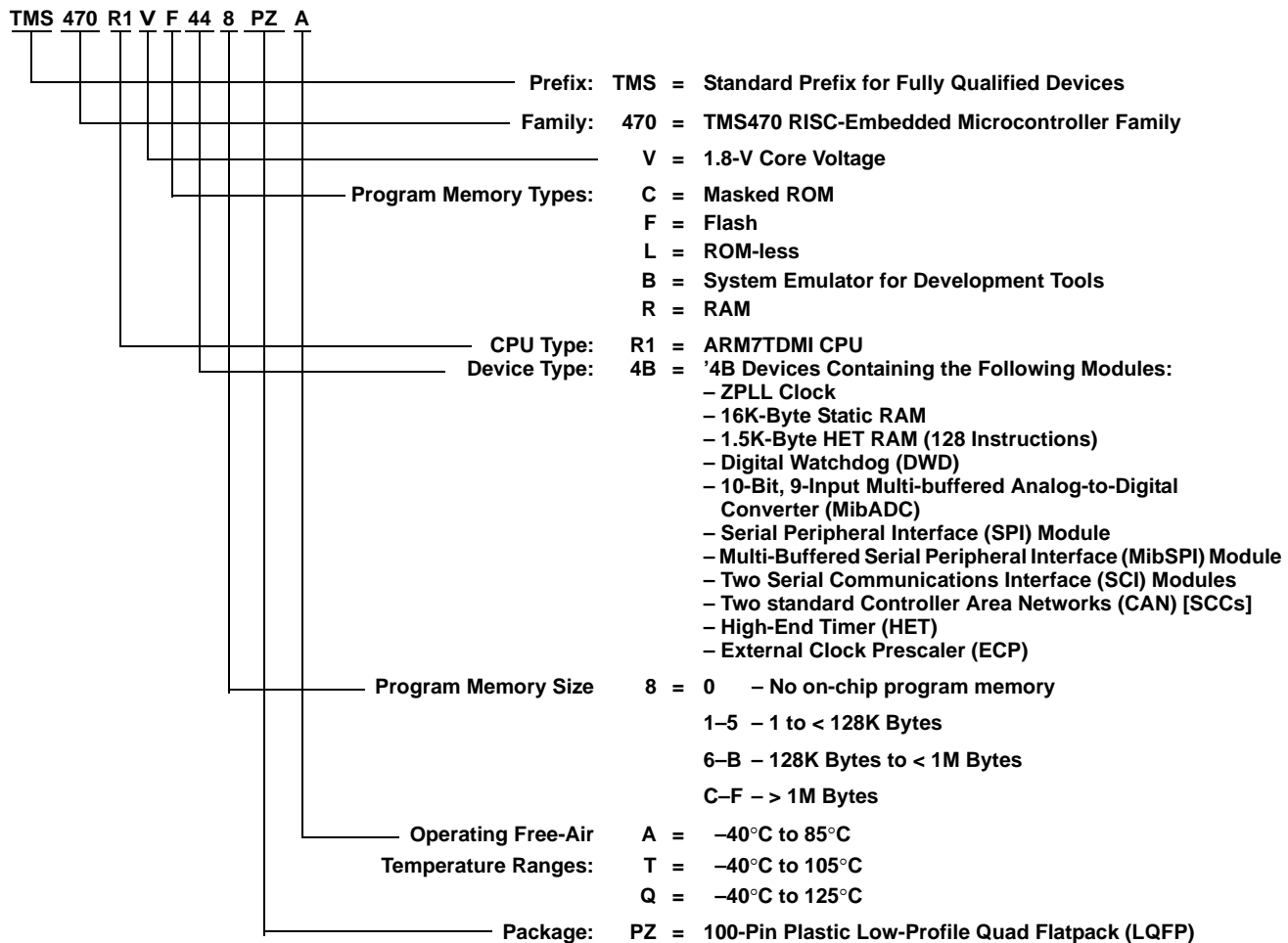

Figure 2. TMS470R1x Family Nomenclature

device identification code register

The device identification code register identifies the silicon version, the technology family (TF), a ROM or flash device, and an assigned device-specific part number (see Table 7). The VF4B8 device identification code register value is 0x1A2F.

Table 7. TMS470 Device ID Bit Allocation Register

	BIT 31	30	29	28	27	26	25	24	23	22	21	20	19	18	17	BIT 16
FFFF_FFF0	Reserved															
	BIT 15	14	13	12	11	10	9	8	7	6	5	4	3	2	1	BIT 0
	VERSION			TF	R/F	PART NUMBER						1	1	1		
	R-K			R-K	R-K	R-K						R-1	R-1	R-1		

LEGEND:

For bits 3–15: R = Read only, -K = Value constant after RESET

For bits 0–2: R = Read only, -1 = Value after RESET

Bits 31:16 **Reserved.** Reads are undefined and writes have no effect.

Bits 15:12 **VERSION.** Silicon version (revision) bits
These bits identify the silicon version of the device.

Bit 11 **TF.** Technology Family (TF) bit
This bit distinguishes the technology family core power supply:
0 = 3.3 V for F10/C10 devices
1 = 1.8 V for F05/C05 devices

Bit 10 **R/F.** ROM/flash bit
This bit distinguishes between ROM and flash devices:
0 = Flash device
1 = ROM device

Bits 9:3 **PART NUMBER.** Device-specific part number bits
These bits identify the assigned device-specific part number.
The assigned device-specific part number for the VF4B8 device is: 1000101.

Bits 2:0 **"1" Mandatory High.** Bits 2, 1, and 0 are tied high by default.

TMS470R1VF4B8

16/32-BIT RISC FLASH MICROCONTROLLER

SPNS094C – JUNE 2004 – REVISED AUGUST 2006

device part numbers

Table 8 lists all the available TMS470R1VF4B8 devices.

Table 8. Device Part Number

DEVICE PART NUMBER	PROGRAM MEMORY		PACKAGE TYPE	TEMPERATURE RANGES		
	ROM	FLASH EEPROM	100-PIN LQFP	-40°C TO 85°C	-40°C TO 105°C	-40°C TO 125°C
TMS470R1VF4B8PZA		X	X	X		
TMS470R1VF4B8PZT		X	X		X	
TMS470R1VF4B8PZQ		X	X			X

DEVICE ELECTRICAL SPECIFICATIONS AND TIMING PARAMETERS

**absolute maximum ratings over operating free-air temperature range, A version
(unless otherwise noted)[†]**

Supply voltage ranges: V_{CC} (see Note 1)	–0.5 V to 2.5 V
Supply voltage ranges: V_{CCIO} , V_{CCAD} , V_{CCP} (flash pump) (see Note 1)	–0.5 V to 4.1 V
Input voltage range: All input pins	–0.5 V to 4.1 V
Input clamp current: I_{IK} ($V_I < 0$ or $V_I > V_{CCIO}$) All pins except ADIN[0:15], \overline{PORRST} , \overline{TRST} , TEST and TCK	± 20 mA
I_{IK} ($V_I < 0$ or $V_I > V_{CCAD}$) ADIN[0:15]	± 10 mA
Operating free-air temperature ranges, T_A : A version	–40°C to 85°C
T version	–40°C to 105°C
Q version	–40°C to 125°C
Operating junction temperature range, T_J : A version	–40°C to 115°C
T version	–40°C to 130°C
Q version	–40°C to 150°C
Storage temperature range, T_{stg}	–40°C to 150°C

[†] Stresses beyond those listed under “absolute maximum ratings” may cause permanent damage to the device. These are stress ratings only, and functional operation of the device at these or any other conditions beyond those indicated under “recommended operating conditions” is not implied. Exposure to absolute-maximum-rated conditions for extended periods may affect device reliability.

NOTE 1: All voltage values are with respect to their associated grounds.

device recommended operating conditions[‡]

		MIN	NOM	MAX	UNIT
V_{CC}	Digital logic and flash supply voltage (Core)	1.81		2.06	V
	When operating at or below 56MHz, 85C ambient temp, and 115C junction temp	1.70		2.06	V
$ZPLL_{V_{CC}}$	ZPLL supply voltage	1.81		2.06	V
	When operating at or below 56MHz, 85C ambient temp, and 115C junction temp	1.70		2.06	V
V_{CCIO}	Digital logic supply voltage (I/O)	3	3.3	3.6	V
V_{CCAD}	ADC supply voltage [‡]	3	3.3	3.6	V
V_{CCP}	Flash pump supply voltage	3	3.3	3.6	V
V_{SS}	Digital logic supply ground		0		V
V_{SSAD}	MibADC supply ground	–0.1		0.1	V
T_A	Operating free-air temperature	–40		85	°C
	A version	–40		105	°C
	T version	–40		125	°C
T_J	Operating junction temperature	–40		150	°C

[‡] All voltages are with respect to V_{SS} , except V_{CCAD} , which is with respect to V_{SSAD} .

TMS470R1VF4B8

16/32-BIT RISC FLASH MICROCONTROLLER

SPNS094C – JUNE 2004 – REVISED AUGUST 2006

electrical characteristics over recommended operating free-air temperature range, A version (unless otherwise noted)†

PARAMETER		TEST CONDITIONS	MIN	TYP	MAX	UNIT	
V_{hys}	Input hysteresis		0.15			V	
V_{IL}	Low-level input voltage	All inputs‡	-0.3		0.8	V	
V_{IH}	High-level input voltage	All inputs	2		$V_{CCIO} + 0.3$	V	
V_{OL}	Low-level output voltage§	$I_{OL} = I_{OL} \text{ MAX}$			$0.2 V_{CCIO}$	V	
		$I_{OL} = 50 \mu\text{A}$			0.2		
V_{OH}	High-level output voltage§	$I_{OH} = I_{OH} \text{ MIN}$			$0.8 V_{CCIO}$	V	
		$I_{OH} = 50 \mu\text{A}$			$V_{CCIO} - 0.2$		
I_{IC}	Input clamp current (I/O pins)¶	$V_I < V_{SSIO} - 0.3$ or $V_I > V_{CCIO} + 0.3$	-2		2	mA	
I_I	Input current (I/O pins)	I_{IL} Pulldown	$V_I = V_{SS}$	-1		1	μA
		I_{IH} Pulldown (20 μA)	$V_I = V_{CCIO}$	5		40	
		I_{IL} Pullup (20 μA)	$V_I = V_{SS}$	-40		-5	
		I_{IH} Pulldown (100 μA)	$V_I = V_{CCIO}$	25		100	
		I_{IL} Pullup (100 μA)	$V_I = V_{SS}$	-200		-100	
		I_{IH} Pullup	$V_I = V_{CCIO}$	-1		1	
		All other pins	No pullup or pulldown	-1		1	
I_{OL}	Low-level output current	CLKOUT, TDO	$V_{OL} = V_{OL} \text{ MAX}$			8	mA
		RST, SPInCLK, SPInSOMI, SPInSIMO, MIBSPICLK, MIBSPISIMO, MIBSPISOMI, TMS2	$V_{OL} = V_{OL} \text{ MAX}$			4	
		All other output pins	$V_{OL} = V_{OL} \text{ MAX}$			2	
I_{OH}	High-level output current	CLKOUT, TDO	$V_{OH} = V_{OH} \text{ MIN}$	-8			mA
		SPInCLK, SPInSOMI, SPInSIMO, MIBSPICLK, MIBSPISIMO, MIBSPISOMI, TMS2	$V_{OH} = V_{OH} \text{ MIN}$	-4			
		All other output pins	$V_{OH} = V_{OH} \text{ MIN}$	-2			
C_I	Input capacitance			2		pF	
C_O	Output capacitance			3		pF	

† Source currents (out of the device) are negative while sink currents (into the device) are positive.

‡ This does not apply to the PORRST pin. For PORRST exceptions, see the RST and PORRST timings section on page 31.

§ V_{OL} and V_{OH} are linear with respect to the amount of load current (I_{OL}/I_{OH}) applied.

¶ Parameter does not apply to input-only or output-only pins.

For flash banks/pumps in sleep mode.

|| I/O pins configured as inputs or outputs with no load. All pulldown inputs ≤ 0.2 V. All pullup inputs $\geq V_{CCIO} - 0.2$ V.

TMS470R1VF4B8

16/32-BIT RISC FLASH MICROCONTROLLER

SPNS094C – JUNE 2004 – REVISED AUGUST 2006

electrical characteristics over recommended operating free-air temperature range, A version (unless otherwise noted)[†] (continued)

PARAMETER		TEST CONDITIONS	MIN	TYP	MAX	UNIT
I_{CC}	V_{CC} digital supply current (operating mode)	SYSCLK = 60 MHz, ICLK = 30 MHz, $V_{CC} = 2.06$ V			90	mA
		SYSCLK = 48 MHz, ICLK = 24 MHz, $V_{CC} = 2.06$ V			75	mA
	V_{CC} digital supply current (standby mode) [#]	OSCIN = 6 MHz, $V_{CC} = 2.06$ V			3.0	mA
	V_{CC} digital supply current (halt mode) [#]	$V_{CC} = 2.06$ V			1.0	mA
I_{CCIO}	V_{CCIO} digital supply current (operating mode)	No DC load, $V_{CCIO} = 3.6$ V			10	mA
	V_{CCIO} digital supply current (standby mode)	No DC load, $V_{CCIO} = 3.6$ V			300	μ A
	V_{CCIO} digital supply current (halt mode)	No DC load, $V_{CCIO} = 3.6$ V			300	μ A
I_{CCAD}	V_{CCAD} supply current (operating mode)	All frequencies, $V_{CCAD} = 3.6$ V			15	mA
	V_{CCAD} supply current (standby mode)	All frequencies, $V_{CCAD} = 3.6$ V			20	μ A
	V_{CCAD} supply current (halt mode)	$V_{CCAD} = 3.6$ V			20	μ A
I_{CCP}	V_{CCP} pump supply current	$V_{CCP} = 3.6$ V read operation SYSCLK = 60 MHz			55	mA
		$V_{CCP} = 3.6$ V read operation SYSCLK = 48 MHz			45	mA
		$V_{CCP} = 3.6$ V program and erase			70	mA
		$V_{CCP} = 3.6$ V standby mode operation [#]			20	μ A
		$V_{CCP} = 3.6$ V halt mode operation [#]			20	μ A

[†] Source currents (out of the device) are negative while sink currents (into the device) are positive.

[‡] This does not apply to the \overline{PORRST} pin. For \overline{PORRST} exceptions, see the \overline{RST} and \overline{PORRST} timings section on page 31.

[§] V_{OL} and V_{OH} are linear with respect to the amount of load current (I_{OL}/I_{OH}) applied.

[¶] Parameter does not apply to input-only or output-only pins.

[#] For flash banks/pumps in sleep mode.

^{||} I/O pins configured as inputs or outputs with no load. All pulldown inputs ≤ 0.2 V. All pullup inputs $\geq V_{CCIO} - 0.2$ V.

Code Composer Studio, XDS510, XDS510WS, XDS510PP, and XDS560 are trademarks of Texas Instruments.



TMS470R1VF4B8 16/32-BIT RISC FLASH MICROCONTROLLER

SPNS094C – JUNE 2004 – REVISED AUGUST 2006

PARAMETER MEASUREMENT INFORMATION

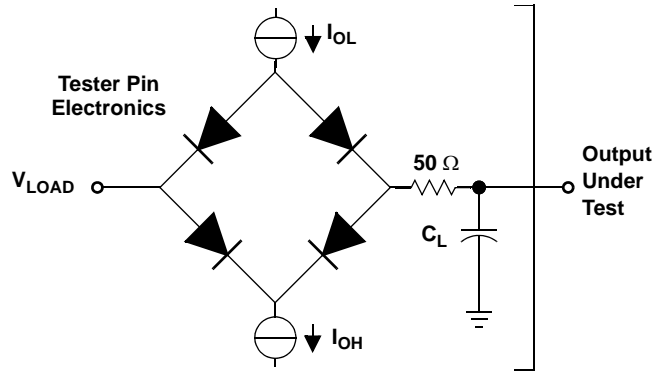

Where: I_{OL} = I_{OL} MAX for the respective pin (see Note A)
 I_{OH} = I_{OH} MIN for the respective pin (see Note A)
 V_{LOAD} = 1.5 V
 C_L = 150-pF typical load-circuit capacitance (see Note B)

NOTES: A. For these values, see the "electrical characteristics over recommended operating free-air temperature range" table.
B. All timing parameters measured using an external load capacitance of 150 pF unless otherwise noted.

Figure 3. Test Load Circuit

timing parameter symbology

Timing parameter symbols have been created in accordance with JEDEC Standard 100. In order to shorten the symbols, some of the pin names and other related terminology have been abbreviated as follows:

CM	Compaction, CMPCT	RD	Read
CO	CLKOUT	RST	Reset, $\overline{\text{RST}}$
ER	Erase	RX	SCInRX
ICLK	Interface clock	S	Slave mode
M	Master mode	SCC	SCInCLK
OSC, OSC1	OSCIN	SIMO	SPInSIMO
OSCO	OSCOU	SOMI	SPInSOMI
P	Program, PROG	SPC	SPInCLK
R	Ready	SYS	System clock
R0	Read margin 0, RDMRGN0	TX	SCInTX
R1	Read margin 1, RDMRGN1		

Lowercase subscripts and their meanings are:

a	access time	r	rise time
c	cycle time (period)	su	setup time
d	delay time	t	transition time
f	fall time	v	valid time
h	hold time	w	pulse duration (width)

The following additional letters are used with these meanings:

H	High	X	Unknown, changing, or don't care level
L	Low	Z	High impedance
V	Valid		

TMS470R1VF4B8

16/32-BIT RISC FLASH MICROCONTROLLER

SPNS094C – JUNE 2004 – REVISED AUGUST 2006

external reference resonator/crystal oscillator clock option

The oscillator is enabled by connecting the appropriate fundamental 4–20 MHz resonator/crystal and load capacitors across the external OSCIN and OSCOUT pins as shown in Figure 4a. The oscillator is a single-stage inverter held in bias by an integrated bias resistor. This resistor is disabled during leakage test measurement and HALT mode. **TI strongly encourages each customer to submit samples of the device to the resonator/crystal vendors for validation.** The vendors are equipped to determine what load capacitors will best tune their resonator/crystal to the microcontroller device for optimum start-up and operation over temperature/voltage extremes.

An external oscillator source can be used by connecting a 1.8 V clock signal to the OSCIN pin and leaving the OSCOUT pin unconnected (open) as shown in Figure 4b.

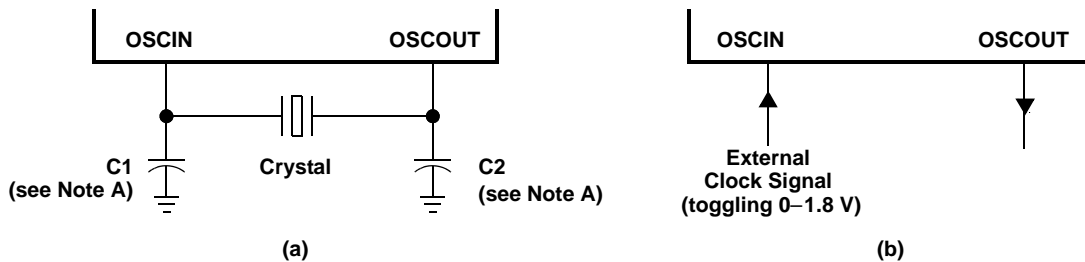

NOTE A: The values of C1 and C2 should be provided by the resonator/crystal vendor.

Figure 4. Crystal/Clock Connection

ZPLL and clock specifications

timing requirements for ZPLL circuits enabled or disabled

		MIN	TYP	MAX	UNIT
$f_{(OSC)}$	Input clock frequency	4		20	MHz
$t_{c(Osc)}$	Cycle time, OSCIN	50			ns
$t_{w(OscIL)}$	Pulse duration, OSCIN low	15			ns
$t_{w(OscIH)}$	Pulse duration, OSCIN high	15			ns
$f_{(OSCRST)}$	OSC FAIL frequency [†]		53		kHz

[†] Causes a device reset (specifically a clock reset) by setting the RST OSC FAIL (GLBCTRL.15) and the OSC FAIL flag (GLBSTAT.1) bits equal to 1. For more detailed information on these bits and device resets, see the *TMS470R1x System Module Reference Guide* (literature number SPNU189).

switching characteristics over recommended operating conditions for clocks^{‡§}

PARAMETER		TEST CONDITIONS [¶]	MIN	MAX	UNIT
$f_{(SYS)}$	System clock frequency [#]	Pipeline mode enabled		64	MHz
		Pipeline mode disabled		24	MHz
$f_{(CONFIG)}$	System clock frequency - flash config mode			24	MHz
$f_{(ICLK)}$	Interface clock frequency	Pipeline mode enabled		32	MHz
		Pipeline mode disabled		24	MHz
$f_{(ECLK)}$	External clock output frequency for ECP Module	Pipeline mode enabled		32	MHz
		Pipeline mode disabled		24	MHz
$t_{c(SYS)}$	Cycle time, system clock	Pipeline mode enabled	15.6		ns
		Pipeline mode disabled	41.6		ns
$t_{c(CONFIG)}$	Cycle time, system clock - flash config mode		41.6		ns
$t_{c(ICLK)}$	Cycle time, interface clock	Pipeline mode enabled	31.25		ns
		Pipeline mode disabled	41.6		ns
$t_{c(ECLK)}$	Cycle time, ECP module external clock output	Pipeline mode enabled	31.25		ns
		Pipeline mode disabled	41.6		ns

[‡] $f_{(SYS)} = M \times f_{(OSC)} / R$, where $M = \{4 \text{ or } 8\}$, $R = \{1, 2, 3, 4, 5, 6, 7, 8\}$ when $PLLDIS = 0$. R is the system-clock divider determined by the CLKDIVPRE [2:0] bits in the global control register (GLBCTRL.[2:0]) and M is the PLL multiplier determined by the MULT4 bit also in the GLBCTRL register (GLBCTRL.3).

$f_{(SYS)} = f_{(OSC)} / R$, where $R = \{1, 2, 3, 4, 5, 6, 7, 8\}$ when $PLLDIS = 1$.

$f_{(ICLK)} = f_{(SYS)} / X$, where $X = \{1, 2, 3, 4, 5, 6, 7, 8, 9, 10, 11, 12, 13, 14, 15, 16\}$. X is the interface clock divider ratio determined by the PCR0.[4:1] bits in the SYS module.

[§] $f_{(ECLK)} = f_{(ICLK)} / N$, where $N = \{1 \text{ to } 256\}$. N is the ECP prescale value defined by the ECPCTRL.[7:0] register bits in the ECP module.

[¶] Pipeline mode enabled or disabled is determined by the ENPIPE bit (FMREGOPT.0).

[#] Flash Vread must be set to 5V to achieve maximum System Clock Frequency.

TMS470R1VF4B8

16/32-BIT RISC FLASH MICROCONTROLLER

SPNS094C – JUNE 2004 – REVISED AUGUST 2006

ZPLL and clock specifications (continued)

switching characteristics over recommended operating conditions for external clocks
(see Figure 5 and Figure 6)^{†‡§}

NO.	PARAMETER	TEST CONDITIONS	MIN	MAX	UNIT
1	$t_{w(COL)}$ Pulse duration, CLKOUT low	SYSCLK or MCLK [¶]	$0.5t_{c(SYS)} - t_f$		ns
		ICLK, X is even or 1 [#]	$0.5t_{c(ICLK)} - t_f$		
		ICLK, X is odd and not 1 [#]	$0.5t_{c(ICLK)} + 0.5t_{c(SYS)} - t_f$		
2	$t_{w(COH)}$ Pulse duration, CLKOUT high	SYSCLK or MCLK [¶]	$0.5t_{c(SYS)} - t_r$		ns
		ICLK, X is even or 1 [#]	$0.5t_{c(ICLK)} - t_r$		
		ICLK, X is odd and not 1 [#]	$0.5t_{c(ICLK)} - 0.5t_{c(SYS)} - t_r$		
3	$t_{w(EOL)}$ Pulse duration, ECLK low	N is even and X is even or odd	$0.5t_{c(ECLK)} - t_f$		ns
		N is odd and X is even	$0.5t_{c(ECLK)} - t_f$		
		N is odd and X is odd and not 1	$0.5t_{c(ECLK)} + 0.5t_{c(SYS)} - t_f$		
4	$t_{w(EOH)}$ Pulse duration, ECLK high	N is even and X is even or odd	$0.5t_{c(ECLK)} - t_r$		ns
		N is odd and X is even	$0.5t_{c(ECLK)} - t_r$		
		N is odd and X is odd and not 1	$0.5t_{c(ECLK)} - 0.5t_{c(SYS)} - t_r$		

[†] X = {1,2,3,4,5,6,7,8,9,10,11,12,13,14,15,16}. X is the interface clock divider ratio determined by the PCR0.[4:1] bits in the SYS module.

[‡] N = {1 to 256}. N is the ECP prescale value defined by the ECPCTRL.[7:0] register bits in the ECP module.

[§] CLKOUT/ECLK pulse durations (low/high) are a function of the OSCIN pulse durations when PLLDIS is active.

[¶] Clock source bits selected as either SYSCLK (CLKCNTL.[6:5] = 11 binary) or MCLK (CLKCNTL.[6:5] = 10 binary).

[#] Clock source bits selected as ICLK (CLKCNTL.[6:5] = 01 binary).

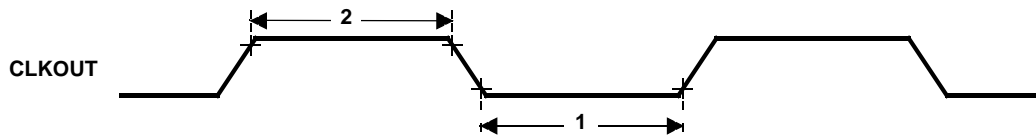

Figure 5. CLKOUT Timing Diagram

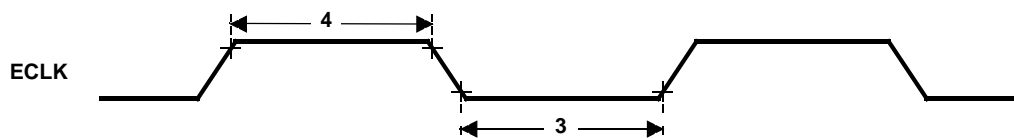

Figure 6. ECLK Timing Diagram

RST and PORRST timings

timing requirements for PORRST (see Figure 7)

NO.		MIN	MAX	UNIT
	V_{CCPORL}	V_{CC} low supply level when \overline{PORRST} must be active during power up		0.6 V
	V_{CCPORH}	V_{CC} high supply level when \overline{PORRST} must remain active during power up and become active during power down		1.5 V
	$V_{CCIOPORL}$	V_{CCIO} low supply level when \overline{PORRST} must be active during power up		1.1 V
	$V_{CCIOPORH}$	V_{CCIO} high supply level when \overline{PORRST} must remain active during power up and become active during power down		2.75 V
	V_{IL}	Low-level input voltage after $V_{CCIO} > V_{CCIOPORH}$		$0.2 V_{CCIO}$ V
	$V_{IL(PORRST)}$	Low-level input voltage of \overline{PORRST} before $V_{CCIO} > V_{CCIOPORL}$		0.5 V
3	$t_{su(PORRST)r}$	Setup time, \overline{PORRST} active before $V_{CCIO} > V_{CCIOPORL}$ during power up		0 ms
5	$t_{su(VCCIO)r}$	Setup time, $V_{CCIO} > V_{CCIOPORL}$ before $V_{CC} > V_{CCPORL}$		0 ms
6	$t_{h(PORRST)r}$	Hold time, \overline{PORRST} active after $V_{CC} > V_{CCPORH}$		1 ms
7	$t_{su(PORRST)f}$	Setup time, \overline{PORRST} active before $V_{CC} \leq V_{CCPORH}$ during power down		8 μ s
8	$t_{h(PORRST)rio}$	Hold time, \overline{PORRST} active after $V_{CC} > V_{CCIOPORH}$		1 ms
9	$t_{h(PORRST)d}$	Hold time, \overline{PORRST} active after $V_{CC} < V_{CCPORL}$		0 ms
10	$t_{su(PORRST)fo}$	Setup time, \overline{PORRST} active before $V_{CC} \leq V_{CCIOPORH}$ during power down		0 ns
11	$t_{su(VCCIO)f}$	Setup time, $V_{CC} < V_{CCPORL}$ before $V_{CCIO} < V_{CCIOPORL}$		0 ns

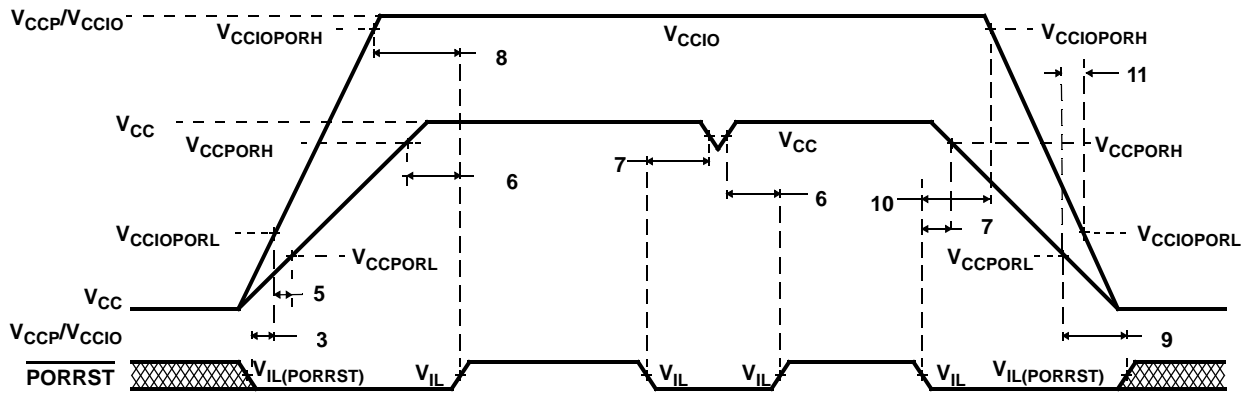

Figure 7. PORRST Timing Diagram

switching characteristics over recommended operating conditions for RST†

PARAMETER		MIN	MAX	UNIT
$t_{v(RST)}$	Valid time, \overline{RST} active after \overline{PORRST} inactive	$4112t_{c(OSC)}$		ns
	Valid time, \overline{RST} active (all others)	$8t_{c(SYS)}$		
t_{fsu}	Flash start up time, from \overline{RST} inactive to fetch of first instruction from flash (flash pump stabilization time)	$836t_{c(OSC)}$		ns

† Specified values do NOT include rise/fall times. For rise and fall timings, see the "switching characteristics for output timings versus load capacitance" table.

TMS470R1VF4B8

16/32-BIT RISC FLASH MICROCONTROLLER

SPNS094C – JUNE 2004 – REVISED AUGUST 2006

JTAG scan interface timing (JTAG clock specification 10-MHz and 50-pF load on TDO output)

NO.		MIN	MAX	UNIT
1	$t_{c(JTAG)}$ Cycle time, JTAG low and high period	50		ns
2	$t_{su(TDI/TMS - TCKr)}$ Setup time, TDI, TMS before TCK rise (TCKr)	15		ns
3	$t_h(TCKr - TDI/TMS)$ Hold time, TDI, TMS after TCKr	15		ns
4	$t_h(TCKf - TDO)$ Hold time, TDO after TCKf	10		ns
5	$t_d(TCKf - TDO)$ Delay time, TDO valid after TCK fall (TCKf)		45	ns

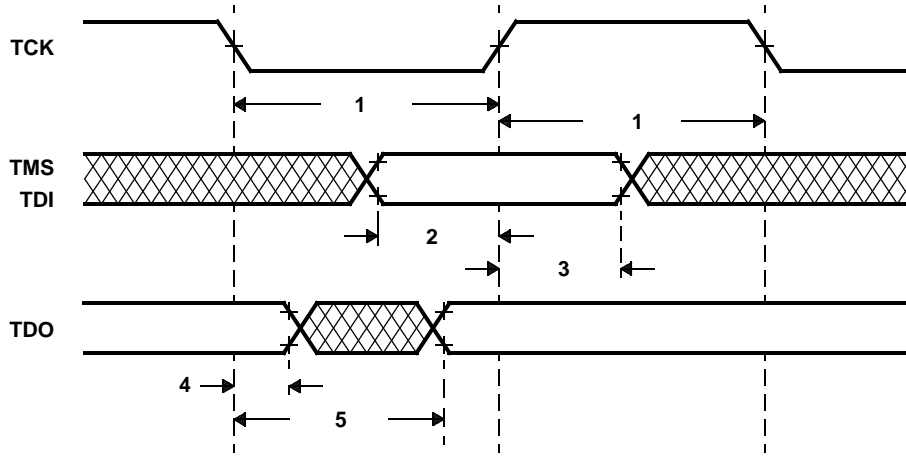

output timings

switching characteristics for output timings versus load capacitance (C_L) (see Figure 8)

PARAMETER		MIN	MAX	UNIT	
t_r	Rise time, CLKOUT, TDO	$C_L = 15 \text{ pF}$	0.5	2.5	ns
		$C_L = 50 \text{ pF}$	1.5	5	
		$C_L = 100 \text{ pF}$	3	9	
		$C_L = 150 \text{ pF}$	4.5	12.5	
t_f	Fall time, CLKOUT, TDO	$C_L = 15 \text{ pF}$	0.5	2.5	ns
		$C_L = 50 \text{ pF}$	1.5	5	
		$C_L = 100 \text{ pF}$	3	9	
		$C_L = 150 \text{ pF}$	4.5	12.5	
t_r	Rise time, SPI2CLK, SPI2SOMI, MIBSPICLK, MIBSPISIMO, MIBSPISOMI, TMS2	$C_L = 15 \text{ pF}$	2.5	8	ns
		$C_L = 50 \text{ pF}$	5	14	
		$C_L = 100 \text{ pF}$	9	23	
		$C_L = 150 \text{ pF}$	13	32	
t_f	Fall time, $\overline{\text{RST}}$, SPI2CLK, SPI2SOMI, MIBSPICLK, MIBSPISIMO, MIBSPISOMI, TMS2	$C_L = 15 \text{ pF}$	2.5	8	ns
		$C_L = 50 \text{ pF}$	5	14	
		$C_L = 100 \text{ pF}$	9	23	
		$C_L = 150 \text{ pF}$	13	32	
t_r	Rise time, all other output pins	$C_L = 15 \text{ pF}$	2.5	10	ns
		$C_L = 50 \text{ pF}$	6.0	25	
		$C_L = 100 \text{ pF}$	12	45	
		$C_L = 150 \text{ pF}$	18	65	
t_f	Fall time, all other output pins	$C_L = 15 \text{ pF}$	3	10	ns
		$C_L = 50 \text{ pF}$	8.5	25	
		$C_L = 100 \text{ pF}$	16	45	
		$C_L = 150 \text{ pF}$	23	65	

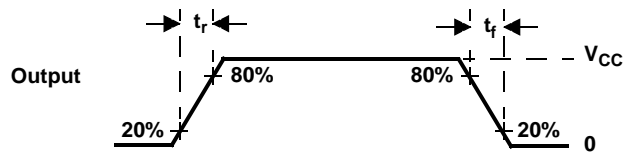

Figure 8. CMOS-Level Outputs

TMS470R1VF4B8

16/32-BIT RISC FLASH MICROCONTROLLER

SPNS094C – JUNE 2004 – REVISED AUGUST 2006

input timings

timing requirements for input timings[†] (see Figure 9)

	MIN	MAX	UNIT
t_{pw} Input minimum pulse width	$t_{c(ICLK)} + 10$		ns

[†] $t_{c(ICLK)}$ = interface clock cycle time = $1/f_{(ICLK)}$

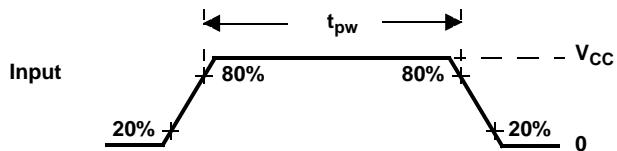

Figure 9. CMOS-Level Inputs

TMS470R1VF4B8

16/32-BIT RISC FLASH MICROCONTROLLER

SPNS094C – JUNE 2004 – REVISED AUGUST 2006

flash timings

timing requirements for program flash[†]

		MIN	TYP	MAX	UNIT
$t_{\text{prog(16-bit)}}$	Half word (16-bit) programming time	4	16	200	μs
$t_{\text{prog(Total)}}$	256K-byte programming time [‡]		2	8	s
$t_{\text{erase(sector)}}$	Sector erase time		2	15	s
t_{wec}	Write/erase cycles at $T_A = 125^\circ\text{C}$	1000		10000	cycles
$t_{\text{p}}(\overline{\text{RST}})$	Flash pump settling time from $\overline{\text{RST}}$ to SLEEP		$167t_{\text{c(SYS)}}$		ns
$t_{\text{p}}(\text{SLEEP})$	Initial flash pump settling time from SLEEP to STANDBY		$167t_{\text{c(SYS)}}$		ns
$t_{\text{p}}(\text{STDBY})$	Initial flash pump settling time from STANDBY to ACTIVE		$84t_{\text{c(SYS)}}$		ns

[†] For more detailed information on the flash core sectors, see the flash program and erase section of this data sheet.

[‡] The 256K-byte programming time include overhead of state machine.

TMS470R1VF4B8

16/32-BIT RISC FLASH MICROCONTROLLER

SPNS094C – JUNE 2004 – REVISED AUGUST 2006

SPI master mode timing parameters

SPI master mode external timing parameters (CLOCK PHASE = 0, SPInCLK = output, SPInSIMO = output, and SPInSOMI = input)^{†‡§} (see Figure 10)

NO.		MIN	MAX	UNIT
1	$t_{c(SPC)M}$ Cycle time, SPInCLK [¶]	100	$256t_{c(ICLK)}$	ns
2 [#]	$t_{w(SPCH)M}$ Pulse duration, SPInCLK high (clock polarity = 0)	$0.5t_{c(SPC)M} - t_r$	$0.5t_{c(SPC)M} + 5$	
	$t_{w(SPCL)M}$ Pulse duration, SPInCLK low (clock polarity = 1)	$0.5t_{c(SPC)M} - t_f$	$0.5t_{c(SPC)M} + 5$	
3 [#]	$t_{w(SPCL)M}$ Pulse duration, SPInCLK low (clock polarity = 0)	$0.5t_{c(SPC)M} - t_f$	$0.5t_{c(SPC)M} + 5$	
	$t_{w(SPCH)M}$ Pulse duration, SPInCLK high (clock polarity = 1)	$0.5t_{c(SPC)M} - t_r$	$0.5t_{c(SPC)M} + 5$	
4 [#]	$t_{d(SPCH-SIMO)M}$ Delay time, SPInCLK high to SPInSIMO valid (clock polarity = 0)		10	
	$t_{d(SPCL-SIMO)M}$ Delay time, SPInCLK low to SPInSIMO valid (clock polarity = 1)		10	
5 [#]	$t_{v(SPCL-SIMO)M}$ Valid time, SPInSIMO data valid	$t_{c(SPC)M} - 5 - t_{r/f}$		
6 [#]	$t_{su(SOMI-SPCL)M}$ Setup time, SPInSOMI before SPInCLK low (clock polarity = 0)	6		
	$t_{su(SOMI-SPCH)M}$ Setup time, SPInSOMI before SPInCLK high (clock polarity = 1)	6		
7 [#]	$t_{v(SPCL-SOMI)M}$ Valid time, SPInSOMI data valid after SPInCLK low (clock polarity = 0)	4		
	$t_{v(SPCH-SOMI)M}$ Valid time, SPInSOMI data valid after SPInCLK high (clock polarity = 1)	4		

[†] The MASTER bit (SPInCTRL2.3) is set and the CLOCK PHASE bit (SPInCTRL2.0) is cleared.

[‡] $t_{c(ICLK)}$ = interface clock cycle time = $1/f_{(ICLK)}$

[§] For rise and fall timings, see the "switching characteristics for output timings versus load capacitance" table.

[¶] When the SPI is in Master mode, the following must be true:

For PS values from 1 to 255: $t_{c(SPC)M} \geq (PS + 1)t_{c(ICLK)} \geq 100$ ns, where PS is the prescale value set in the SPInCTL1.[12:5] register bits.

For PS values of 0: $t_{c(SPC)M} = 2t_{c(ICLK)} \geq 100$ ns.

[#] The active edge of the SPInCLK signal referenced is controlled by the CLOCK POLARITY bit (SPInCTRL2.1).

SPI master mode timing parameters (continued)

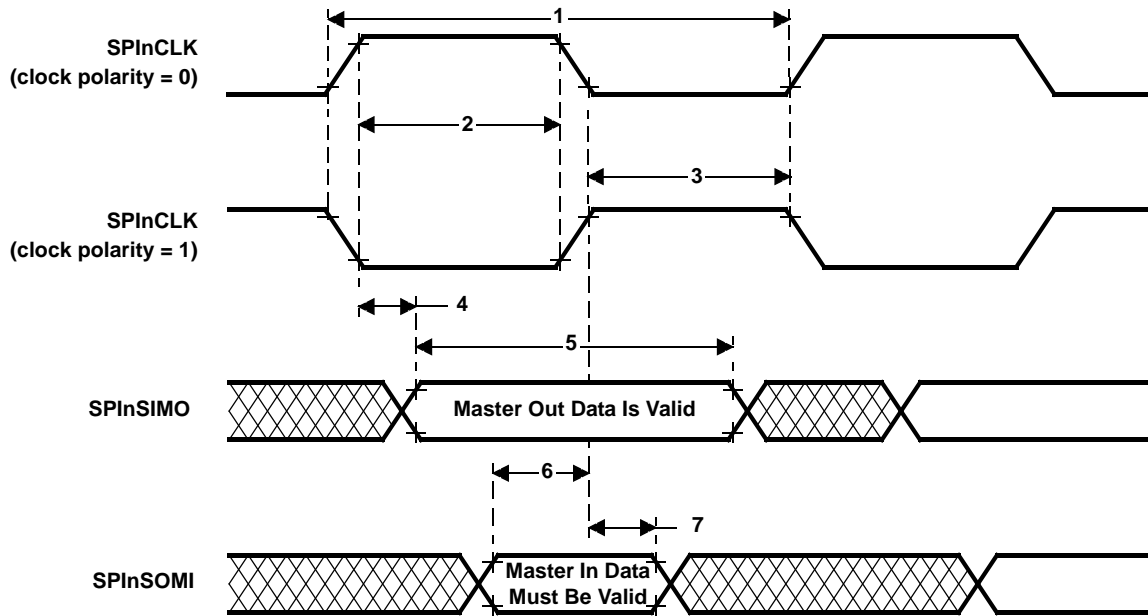

Figure 10. SPIn Master Mode External Timing (CLOCK PHASE = 0)

TMS470R1VF4B8

16/32-BIT RISC FLASH MICROCONTROLLER

SPNS094C – JUNE 2004 – REVISED AUGUST 2006

SPI master mode timing parameters (continued)

SPI master mode external timing parameters (CLOCK PHASE = 1, SPInCLK = output, SPInSIMO = output, and SPInSOMI = input)^{†‡§} (see Figure 11)

NO.		MIN	MAX	UNIT
1	$t_{c(SPC)M}$ Cycle time, SPInCLK [¶]	100	$256t_{c(ICLK)}$	ns
2 [#]	$t_{w(SPCH)M}$ Pulse duration, SPInCLK high (clock polarity = 0)	$0.5t_{c(SPC)M} - t_r$	$0.5t_{c(SPC)M} + 5$	
	$t_{w(SPCL)M}$ Pulse duration, SPInCLK low (clock polarity = 1)	$0.5t_{c(SPC)M} - t_f$	$0.5t_{c(SPC)M} + 5$	
3 [#]	$t_{w(SPCL)M}$ Pulse duration, SPInCLK low (clock polarity = 0)	$0.5t_{c(SPC)M} - t_f$	$0.5t_{c(SPC)M} + 5$	
	$t_{w(SPCH)M}$ Pulse duration, SPInCLK high (clock polarity = 1)	$0.5t_{c(SPC)M} - t_r$	$0.5t_{c(SPC)M} + 5$	
4 [#]	$t_{v(SIMO-SPCH)M}$ Valid time, SPInCLK high after SPInSIMO data valid (clock polarity = 0)	$0.5t_{c(SPC)M} - 10$		
	$t_{v(SIMO-SPCL)M}$ Valid time, SPInCLK low after SPInSIMO data valid (clock polarity = 1)	$0.5t_{c(SPC)M} - 10$		
5 [#]	$t_{v(SPCH-SIMO)M}$ Valid time, SPInSIMO data valid after SPInCLK high (clock polarity = 0)	$0.5t_{c(SPC)M} - 5 - t_r$		
	$t_{v(SPCL-SIMO)M}$ Valid time, SPInSIMO data valid after SPInCLK low (clock polarity = 1)	$0.5t_{c(SPC)M} - 5 - t_f$		
6 [#]	$t_{su(SOMI-SPCH)M}$ Setup time, SPInSOMI before SPInCLK high (clock polarity = 0)	6		
	$t_{su(SOMI-SPCL)M}$ Setup time, SPInSOMI before SPInCLK low (clock polarity = 1)	6		
7 [#]	$t_{v(SPCH-SOMI)M}$ Valid time, SPInSOMI data valid after SPInCLK high (clock polarity = 0)	4		
	$t_{v(SPCL-SOMI)M}$ Valid time, SPInSOMI data valid after SPInCLK low (clock polarity = 1)	4		

[†] The MASTER bit (SPInCTRL2.3) is set and the CLOCK PHASE bit (SPInCTRL2.0) is set.

[‡] $t_{c(ICLK)}$ = interface clock cycle time = $1/f_{(ICLK)}$

[§] For rise and fall timings, see the "switching characteristics for output timings versus load capacitance" table.

[¶] When the SPI is in Master mode, the following must be true:

For PS values from 1 to 255: $t_{c(SPC)M} \geq (PS + 1)t_{c(ICLK)} \geq 100$ ns, where PS is the prescale value set in the SPInCTL1.[12:5] register bits.

For PS values of 0: $t_{c(SPC)M} = 2t_{c(ICLK)} \geq 100$ ns.

[#] The active edge of the SPInCLK signal referenced is controlled by the CLOCK POLARITY bit (SPInCTRL2.1).

SPIn master mode timing parameters (continued)

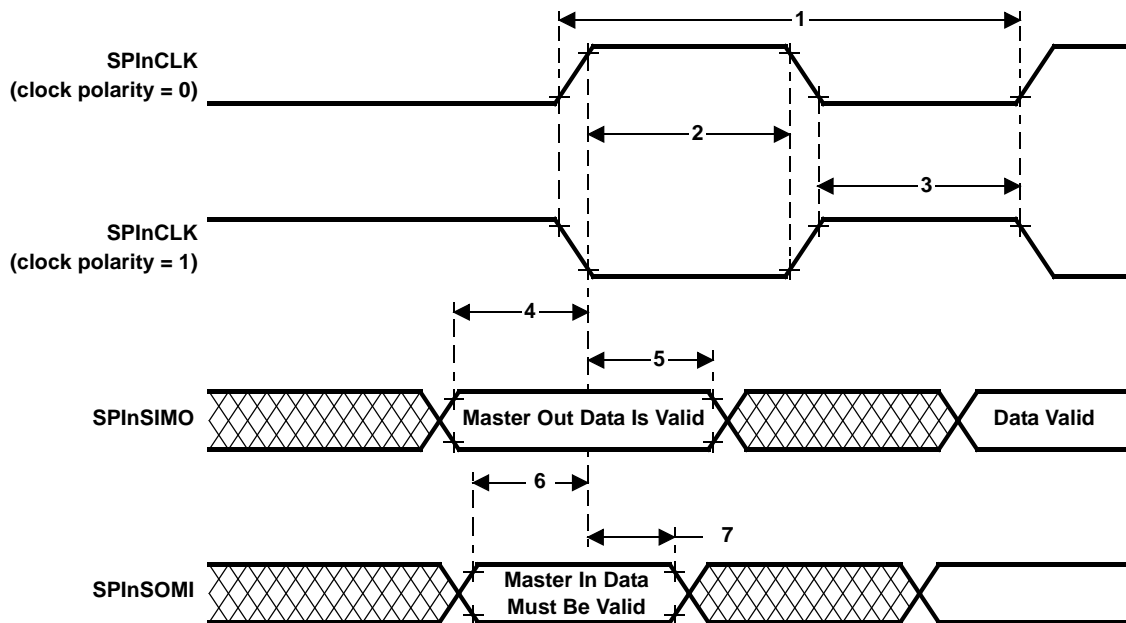

Figure 11. SPIn Master Mode External Timing (CLOCK PHASE = 1)

TMS470R1VF4B8

16/32-BIT RISC FLASH MICROCONTROLLER

SPNS094C – JUNE 2004 – REVISED AUGUST 2006

SPIn slave mode timing parameters

SPIn slave mode external timing parameters (CLOCK PHASE = 0, SPInCLK = input, SPInSIMO = input, and SPInSOMI = output)^{†‡§¶} (see Figure 12)

NO			MIN	MAX	UNIT
1	$t_{c(SPC)S}$	Cycle time, SPInCLK [#]	100	$256t_{c(I)CLK}$	ns
2	$t_{w(SPCH)S}$	Pulse duration, SPInCLK high (clock polarity = 0)	$0.5t_{c(SPC)S} - 0.25t_{c(I)CLK}$	$0.5t_{c(SPC)S} + 0.25t_{c(I)CLK}$	
	$t_{w(SPCL)S}$	Pulse duration, SPInCLK low (clock polarity = 1)	$0.5t_{c(SPC)S} - 0.25t_{c(I)CLK}$	$0.5t_{c(SPC)S} + 0.25t_{c(I)CLK}$	
3	$t_{w(SPCL)S}$	Pulse duration, SPInCLK low (clock polarity = 0)	$0.5t_{c(SPC)S} - 0.25t_{c(I)CLK}$	$0.5t_{c(SPC)S} + 0.25t_{c(I)CLK}$	
	$t_{w(SPCH)S}$	Pulse duration, SPInCLK high (clock polarity = 1)	$0.5t_{c(SPC)S} - 0.25t_{c(I)CLK}$	$0.5t_{c(SPC)S} + 0.25t_{c(I)CLK}$	
4	$t_{d(SPCH-SOMI)S}$	Delay time, SPInCLK high to SPInSOMI valid (clock polarity = 0)		$12 + t_r$	
	$t_{d(SPCL-SOMI)S}$	Delay time, SPInCLK low to SPInSOMI valid (clock polarity = 1)		$12 + t_f$	
5	$t_{v(SPCH-SOMI)S}$	Valid time, SPInSOMI data valid after SPInCLK high (clock polarity = 0)	$t_{c(SPC)S} - 6 - t_r$		
	$t_{v(SPCL-SOMI)S}$	Valid time, SPInSOMI data valid after SPInCLK low (clock polarity = 1)	$t_{c(SPC)S} - 6 - t_f$		
6	$t_{su(SIMO-SPCL)S}$	Setup time, SPInSIMO before SPInCLK low (clock polarity = 0)	6		
	$t_{su(SIMO-SPCH)S}$	Setup time, SPInSIMO before SPInCLK high (clock polarity = 1)	6		
7	$t_{v(SPCL-SIMO)S}$	Valid time, SPInSIMO data valid after SPInCLK low (clock polarity = 0)	6		
	$t_{v(SPCH-SIMO)S}$	Valid time, SPInSIMO data valid after SPInCLK high (clock polarity = 1)	6		

† The MASTER bit (SPInCTRL2.3) is cleared and the CLOCK PHASE bit (SPInCTRL2.0) is cleared.

‡ If the SPI is in slave mode, the following must be true: $t_{c(SPC)S} \geq (PS + 1)t_{c(I)CLK}$, where PS = prescale value set in SPInCTL1.[12:5].

§ For rise and fall timings, see the "switching characteristics for output timings versus load capacitance" table.

¶ $t_{c(I)CLK} = \text{interface clock cycle time} = 1/f_{(I)CLK}$

When the SPIn is in Slave mode, the following must be true:

For PS values from 1 to 255: $t_{c(SPC)S} \geq (PS + 1)t_{c(I)CLK} \geq 100$ ns, where PS is the prescale value set in the SPInCTL1.[12:5] register bits.

For PS values of 0: $t_{c(SPC)S} = 2t_{c(I)CLK} \geq 100$ ns.

|| The active edge of the SPInCLK signal referenced is controlled by the CLOCK POLARITY bit (SPInCTRL2.1).

SPI slave mode timing parameters (continued)

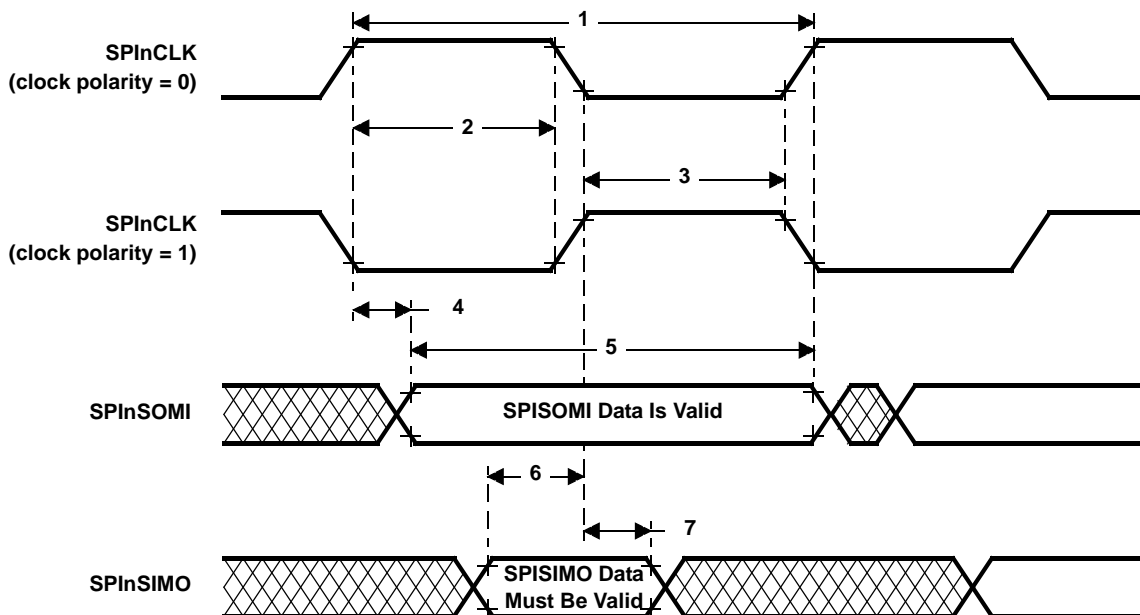

Figure 12. SPI Slave Mode External Timing (CLOCK PHASE = 0)

TMS470R1VF4B8

16/32-BIT RISC FLASH MICROCONTROLLER

SPNS094C – JUNE 2004 – REVISED AUGUST 2006

SPIn slave mode timing parameters (continued)

SPIn slave mode external timing parameters (CLOCK PHASE = 1, SPInCLK = input, SPInSIMO = input, and SPInSOMI = output)^{†‡§¶} (see Figure 13)

NO		MIN	MAX	UNIT
1	$t_{c(SPC)S}$ Cycle time, SPInCLK [#]	100	$256t_{c(ICLK)}$	ns
2	$t_{w(SPCH)S}$ Pulse duration, SPInCLK high (clock polarity = 0)	$0.5t_{c(SPC)S} - 0.25t_{c(ICLK)}$	$0.5t_{c(SPC)S} + 0.25t_{c(ICLK)}$	
	$t_{w(SPCL)S}$ Pulse duration, SPInCLK low (clock polarity = 1)	$0.5t_{c(SPC)S} - 0.25t_{c(ICLK)}$	$0.5t_{c(SPC)S} + 0.25t_{c(ICLK)}$	
3	$t_{w(SPCL)S}$ Pulse duration, SPInCLK low (clock polarity = 0)	$0.5t_{c(SPC)S} - 0.25t_{c(ICLK)}$	$0.5t_{c(SPC)S} + 0.25t_{c(ICLK)}$	
	$t_{w(SPCH)S}$ Pulse duration, SPInCLK high (clock polarity = 1)	$0.5t_{c(SPC)S} - 0.25t_{c(ICLK)}$	$0.5t_{c(SPC)S} + 0.25t_{c(ICLK)}$	
4	$t_{v(SOMI-SPCH)S}$ Valid time, SPInCLK high after SPInSOMI data valid (clock polarity = 0)	$0.5t_{c(SPC)S} - 6 - t_r$		
	$t_{v(SOMI-SPCL)S}$ Valid time, SPInCLK low after SPInSOMI data valid (clock polarity = 1)	$0.5t_{c(SPC)S} - 6 - t_f$		
5	$t_{v(SPCH-SOMI)S}$ Valid time, SPInSOMI data valid after SPInCLK high (clock polarity = 0)	$0.5t_{c(SPC)S} - 6 - t_r$		
	$t_{v(SPCL-SOMI)S}$ Valid time, SPInSOMI data valid after SPInCLK low (clock polarity = 1)	$0.5t_{c(SPC)S} - 6 - t_f$		
6	$t_{su(SIMO-SPCH)S}$ Setup time, SPInSIMO before SPInCLK high (clock polarity = 0)	6		
	$t_{su(SIMO-SPCL)S}$ Setup time, SPInSIMO before SPInCLK low (clock polarity = 1)	6		
7	$t_{v(SPCH-SIMO)S}$ Valid time, SPInSIMO data valid after SPInCLK high (clock polarity = 0)	6		
	$t_{v(SPCL-SIMO)S}$ Valid time, SPInSIMO data valid after SPInCLK low (clock polarity = 1)	6		

[†] The MASTER bit (SPInCTRL2.3) is cleared and the CLOCK PHASE bit (SPInCTRL2.0) is set.

[‡] If the SPI is in slave mode, the following must be true: $t_{c(SPC)S} \geq (PS + 1) t_{c(ICLK)}$, where PS = prescale value set in SPInCTL1.[12:5].

[§] For rise and fall timings, see the "switching characteristics for output timings versus load capacitance" table.

[¶] $t_{c(ICLK)}$ = interface clock cycle time = $1/f_{(ICLK)}$

[#] When the SPIn is in Slave mode, the following must be true:

For PS values from 1 to 255: $t_{c(SPC)S} \geq (PS + 1)t_{c(ICLK)} \geq 100$ ns, where PS is the prescale value set in the SPInCTL1.[12:5] register bits.

For PS values of 0: $t_{c(SPC)S} = 2t_{c(ICLK)} \geq 100$ ns.

^{||} The active edge of the SPInCLK signal referenced is controlled by the CLOCK POLARITY bit (SPInCTRL2.1).

SPIn slave mode timing parameters (continued)

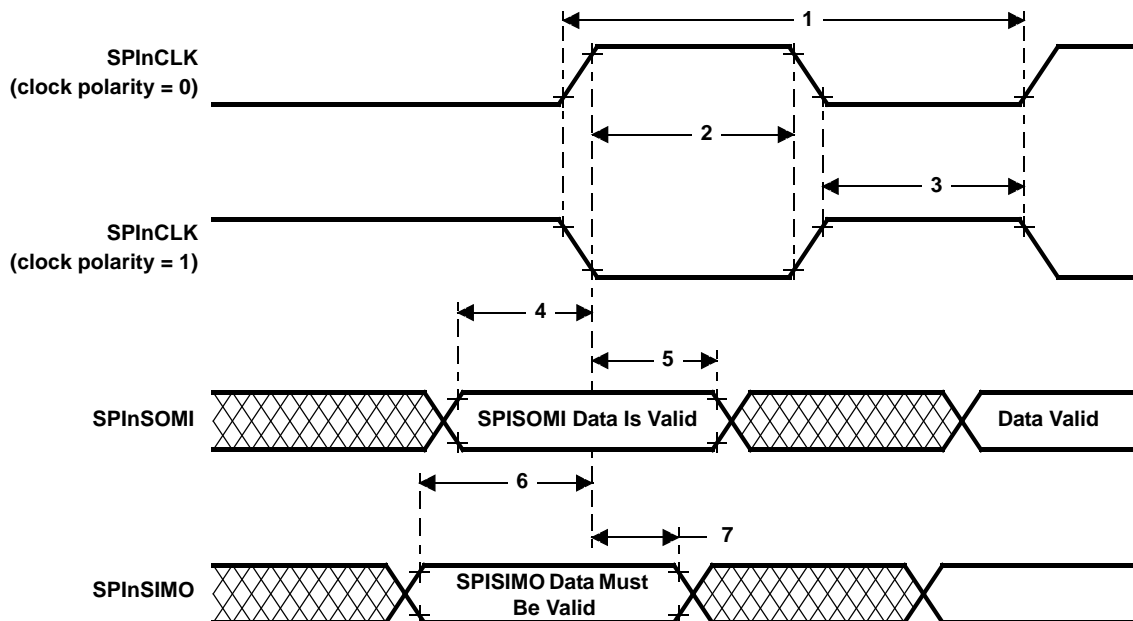

Figure 13. SPIn Slave Mode External Timing (CLOCK PHASE = 1)

TMS470R1VF4B8

16/32-BIT RISC FLASH MICROCONTROLLER

SPNS094C – JUNE 2004 – REVISED AUGUST 2006

MibSPI master mode timing parameters

MibSPI master mode external timing parameters (CLOCK PHASE = 0, SPICLK = output, SPISIMO = output, and SPISOMI = input)^{†‡§} (see Figure 14)

NO.		MIN	MAX	UNIT
1	$t_{c(SPC)M}$ Cycle time, SPICLK [¶]	$2t_{c(ICK)K}$	$256t_{c(ICK)K}$	ns
2 [¶]	$t_{w(SPCH)M}$ Pulse duration, SPICLK high (clock polarity = 0)	$0.5t_{c(SPC)M} - t_r$	$0.5t_{c(SPC)M} + 5$	ns
	$t_{w(SPCL)M}$ Pulse duration, SPICLK low (clock polarity = 1)	$0.5t_{c(SPC)M} - t_f$	$0.5t_{c(SPC)M} + 5$	
3 [¶]	$t_{w(SPCL)M}$ Pulse duration, SPICLK low (clock polarity = 0)	$0.5t_{c(SPC)M} - t_f$	$0.5t_{c(SPC)M} + 5$	ns
	$t_{w(SPCH)M}$ Pulse duration, SPICLK high (clock polarity = 1)	$0.5t_{c(SPC)M} - t_r$	$0.5t_{c(SPC)M} + 5$	
4 [¶]	$t_{d(SPCH-SIMO)M}$ Delay time, SPICLK high to SPISIMO valid (clock polarity = 0)		6	ns
	$t_{d(SPCL-SIMO)M}$ Delay time, SPICLK low to SPISIMO valid (clock polarity = 1)		6	
5 [¶]	$t_{v(SPCL-SIMO)M}$ Valid time, SPISIMO data valid after SPICLK low (clock polarity = 0)	$0.5t_{c(SPC)M} - 5 - t_f$		ns
	$t_{v(SPCH-SIMO)M}$ Valid time, SPISIMO data valid after SPICLK high (clock polarity = 1)	$0.5t_{c(SPC)M} - 5 - t_r$		
6 [¶]	$t_{d(SOMI-SPCL)M}$ Delay time, SPISOMI after SPICLK low (clock polarity = 0)		$0.5t_{clk} - 10 - t_{r(max)}$	ns
	$t_{d(SOMI-SPCH)M}$ Delay time, SPISOMI after SPICLK high (clock polarity = 1)		$0.5t_{clk} - 10 - t_{r(max)}$	
7 [¶]	$t_{v(SPCL-SOMI)M}$ Valid time, SPISOMI data valid after SPICLK low (clock polarity = 0)	$t_{clk} - t_{r(min)}$		ns
	$t_{v(SPCH-SOMI)M}$ Valid time, SPISOMI data valid after SPICLK high (clock polarity = 1)	$t_{clk} - t_{r(min)}$		

[†] The MASTER bit (SPICTRL2.3) is set and the CLOCK PHASE bit (SPICTRL2.0) is cleared.

[‡] $t_{c(ICK)K}$ = interface clock cycle time = $1/f_{(ICK)K}$

[§] For rise and fall timings, see the "switching characteristics for output timings versus load capacitance" table.

[¶] The active edge of the SPICLK signal referenced is controlled by the CLOCK POLARITY bit (SPICTRK2.1).

MibSPI master mode timing parameters (continued)

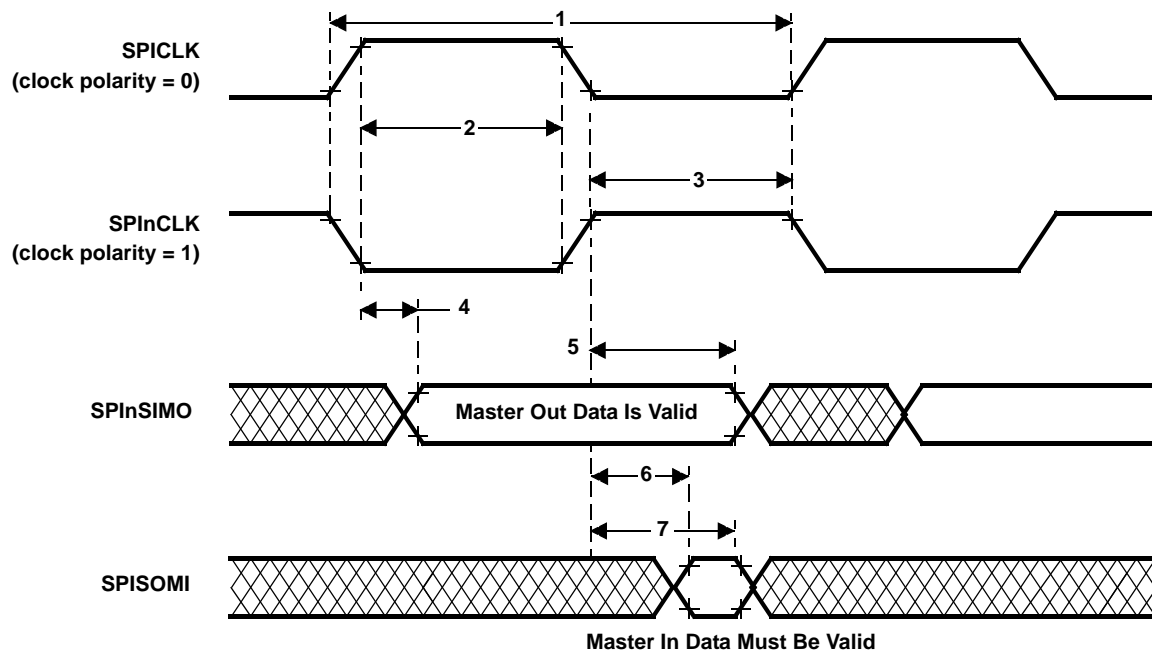

Figure 14. MibSPI Master Mode External Timing (CLOCK PHASE = 0)

TMS470R1VF4B8

16/32-BIT RISC FLASH MICROCONTROLLER

SPNS094C – JUNE 2004 – REVISED AUGUST 2006

MibSPI master mode timing parameters (continued)

MibSPI master mode external timing parameters (CLOCK PHASE = 1, SPICLK = output, SPISIMO = output, and SPISOMI = input)^{†‡§} (see Figure 15)

NO.			MIN	MAX	UNIT
1	$t_{c(SPC)M}$	Cycle time, SPICLK ¶	$2t_{c(ICLK)}$	$256t_{c(ICLK)}$	ns
2¶	$t_{w(SPCH)M}$	Pulse duration, SPICLK high (clock polarity = 0)	$0.5t_{c(SPC)M} - t_r$	$0.5t_{c(SPC)M} + 5$	ns
	$t_{w(SPCL)M}$	Pulse duration, SPICLK low (clock polarity = 1)	$0.5t_{c(SPC)M} - t_f$	$0.5t_{c(SPC)M} + 5$	
3¶	$t_{w(SPCL)M}$	Pulse duration, SPICLK low (clock polarity = 0)	$0.5t_{c(SPC)M} - t_f$	$0.5t_{c(SPC)M} + 5$	ns
	$t_{w(SPCH)M}$	Pulse duration, SPICLK high (clock polarity = 1)	$0.5t_{c(SPC)M} - t_r$	$0.5t_{c(SPC)M} + 5$	
4¶	$t_{v(SIMO-SPCH)M}$	Valid time, SPICLK high after SPISIMO data valid (clock polarity = 0)	$0.5t_{c(SPC)M} - 6$		ns
	$t_{v(SIMO-SPCL)M}$	Valid time, SPICLK low after SPISIMO data valid (clock polarity = 1)	$0.5t_{c(SPC)M} - 6$		
5¶	$t_{v(SPCH-SIMO)M}$	Valid time, SPISIMO data valid after SPICLK high (clock polarity = 0)	$0.5t_{c(SPC)M} - 5 - t_r$		ns
	$t_{v(SPCL-SIMO)M}$	Valid time, SPISIMO data valid after SPICLK low (clock polarity = 1)	$0.5t_{c(SPC)M} - 5 - t_f$		
6¶	$t_{d(SOMI-SPCH)M}$	Delay time, SPISOMI after SPICLK high (clock polarity = 0)	$0.5t_{iclk} - 10 - t_{r(max)}$		ns
	$t_{d(SOMI-SPCL)M}$	Delay time, SPISOMI after SPICLK low (clock polarity = 1)	$0.5t_{iclk} - 10 - t_{f(max)}$		
7¶	$t_{v(SPCH-SOMI)M}$	Valid time, SPISOMI data valid after SPICLK high (clock polarity = 0)	$t_{iclk} - t_{r(min)}$		ns
	$t_{v(SPCL-SOMI)M}$	Valid time, SPISOMI data valid after SPICLK low (clock polarity = 1)	$t_{iclk} - t_{f(min)}$		

† The MASTER bit (SPICTRL2.3) is set and the CLOCK PHASE bit (SPICTRL2.0) is set.

‡ $t_{c(ICLK)}$ = interface clock cycle time = $1/f_{(ICLK)}$

§ For rise and fall timings, see the "switching characteristics for output timings versus load capacitance" table.

¶ The active edge of the SPICLK signal referenced is controlled by the CLOCK POLARITY bit (SPICTRL2.1).

MibSPI master mode timing parameters (continued)

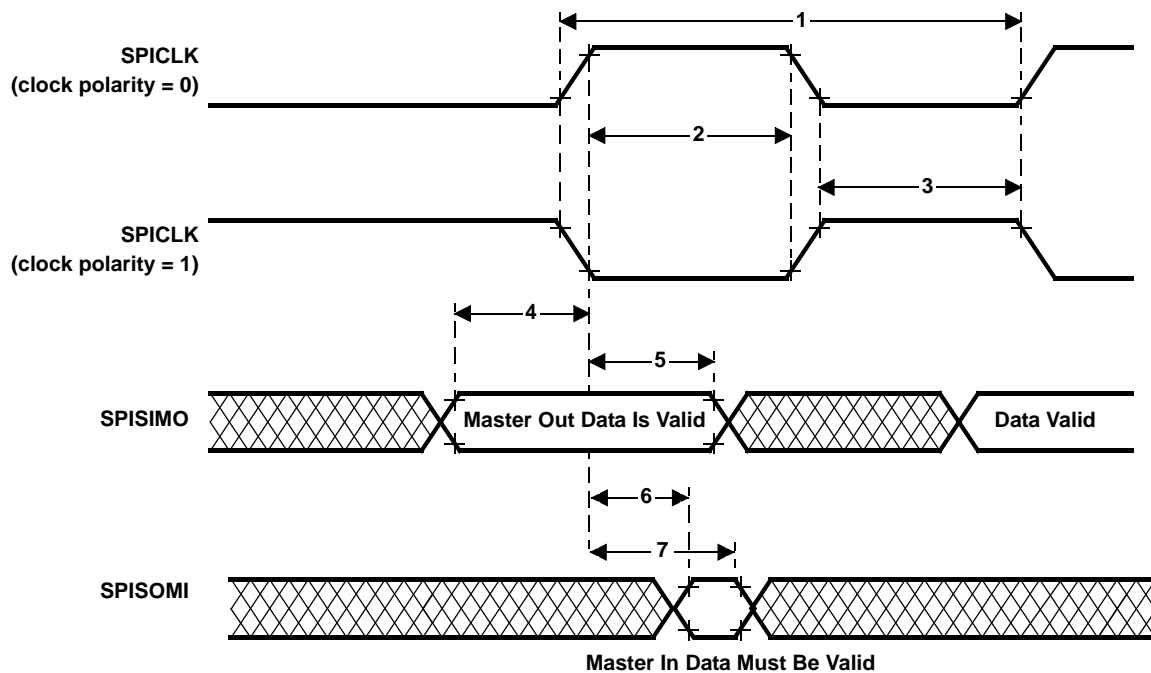

Figure 15. MibSPI Master Mode External Timing (CLOCK PHASE = 1)

TMS470R1VF4B8

16/32-BIT RISC FLASH MICROCONTROLLER

SPNS094C – JUNE 2004 – REVISED AUGUST 2006

SCIn isosynchronous mode timings — internal clock

timing requirements for internal clock SCIn isosynchronous mode^{†‡§} (see Figure 16)

NO.		(BAUD + 1) IS EVEN OR BAUD = 0		(BAUD + 1) IS ODD AND BAUD ≠ 0		UNIT
		MIN	MAX	MIN	MAX	
1	$t_{c(SCC)}$ Cycle time, SCInCLK	$2t_{c(ICKL)}$	$2^{24}t_{c(ICKL)}$	$3t_{c(ICKL)}$	$(2^{24} - 1)t_{c(ICKL)}$	ns
2	$t_w(SCCL)$ Pulse duration, SCInCLK low	$0.5t_{c(SCC)} - t_f$	$0.5t_{c(SCC)} + 5$	$0.5t_{c(SCC)} + 0.5t_{c(ICKL)} - t_f$	$0.5t_{c(SCC)} + 0.5t_{c(ICKL)}$	ns
3	$t_w(SCCH)$ Pulse duration, SCInCLK high	$0.5t_{c(SCC)} - t_f$	$0.5t_{c(SCC)} + 5$	$0.5t_{c(SCC)} - 0.5t_{c(ICKL)} - t_f$	$0.5t_{c(SCC)} - 0.5t_{c(ICKL)}$	ns
4	$t_d(SCCH-TXV)$ Delay time, SCInCLK high to SCInTX valid		10		10	ns
5	$t_v(TX)$ Valid time, SCInTX data after SCInCLK low	$t_{c(SCC)} - 10$		$t_{c(SCC)} - 10$		ns
6	$t_{su}(RX-SCCL)$ Setup time, SCInRX before SCInCLK low	$t_{c(ICKL)} + t_f + 20$		$t_{c(ICKL)} + t_f + 20$		ns
7	$t_v(SCCL-RX)$ Valid time, SCInRX data after SCInCLK low	$-t_{c(ICKL)} + t_f + 20$		$-t_{c(ICKL)} + t_f + 20$		ns

† BAUD = 24-bit concatenated value formed by the SCI[H,M,L]BAUD registers.

‡ $t_{c(ICKL)}$ = interface clock cycle time = $1/f_{(ICKL)}$

§ For rise and fall timings, see the switching characteristics for output timings versus load capacitance table.

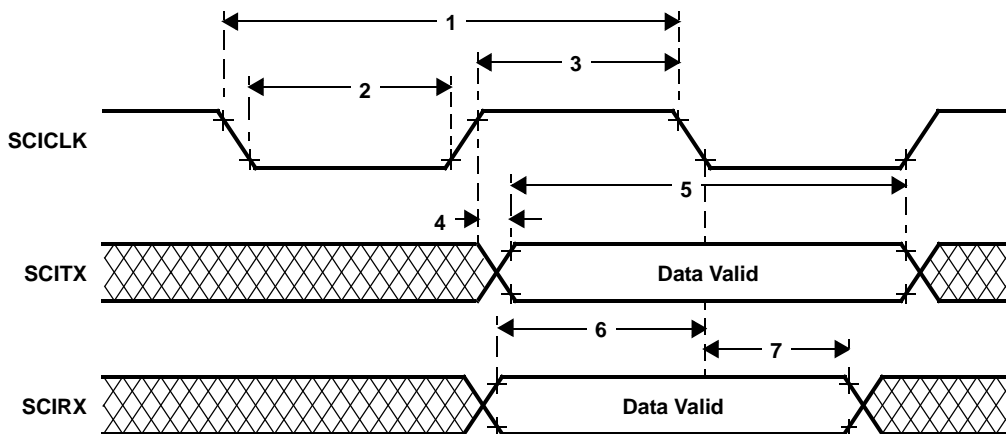

NOTE A: Data transmission/reception characteristics for isosynchronous mode with internal clocking are similar to the asynchronous mode. Data transmission occurs on the SCICLK rising edge, and data reception on the SCICLK falling edge.

Figure 16. SCIn Isosynchronous Mode Timing Diagram for Internal Clock

SCIn isosynchronous mode timings — external clock

timing requirements for external clock SCIn isosynchronous mode^{†‡} (see Figure 17)

NO.		MIN	MAX	UNIT
1	$t_{c(SCC)}$ Cycle time, SCInCLK [§]	$8t_{c(ICKL)}$		ns
2	$t_{w(SCCH)}$ Pulse duration, SCInCLK high	$0.5t_{c(SCC)} - 0.25t_{c(ICKL)}$	$0.5t_{c(SCC)} + 0.25t_{c(ICKL)}$	ns
3	$t_{w(SCCL)}$ Pulse duration, SCInCLK low	$0.5t_{c(SCC)} - 0.25t_{c(ICKL)}$	$0.5t_{c(SCC)} + 0.25t_{c(ICKL)}$	ns
4	$t_{d(SCCH-TXV)}$ Delay time, SCInCLK high to SCInTX valid		$2t_{c(ICKL)} + 12 + t_r$	ns
5	$t_{v(TX)}$ Valid time, SCInTX data after SCInCLK low	$2t_{c(SCC)} - 10$		ns
6	$t_{su(RX-SCCL)}$ Setup time, SCInRX before SCInCLK low	0		ns
7	$t_{v(SCCL-RX)}$ Valid time, SCInRX data after SCInCLK low	$2t_{c(ICKL)} + 10$		ns

[†] $t_{c(ICKL)}$ = interface clock cycle time = $1/f_{(ICKL)}$

[‡] For rise and fall timings, see the "switching characteristics for output timings versus load capacitance" table.

[§] When driving an external SCInCLK, the following must be true: $t_{c(SCC)} \geq 8t_{c(ICKL)}$

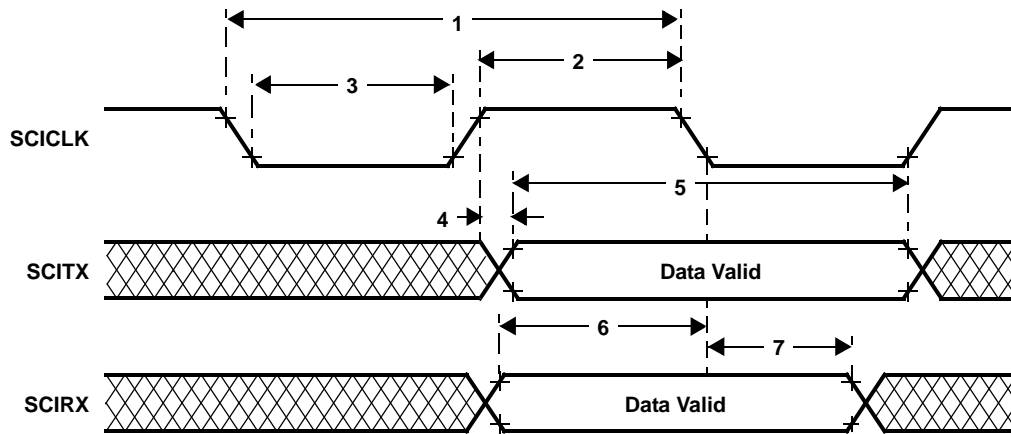

NOTE A: Data transmission/reception characteristics for isosynchronous mode with external clocking are similar to the asynchronous mode. Data transmission occurs on the SCICLK rising edge, and data reception on the SCICLK falling edge.

Figure 17. SCIn Isosynchronous Mode Timing Diagram for External Clock

TMS470R1VF4B8

16/32-BIT RISC FLASH MICROCONTROLLER

SPNS094C – JUNE 2004 – REVISED AUGUST 2006

standard CAN controller (SCC) mode timings

dynamic characteristics for the CANSTX and CANSRX pins

PARAMETER		MIN	MAX	UNIT
$t_d(\text{CANSTX})$	Delay time, transmit shift register to CANSTX pin [†]		15	ns
$t_d(\text{CANSRX})$	Delay time, CANSRX pin to receive shift register		5	ns

[†] These values do not include rise/fall times of the output buffer.

high-end timer (HET) timings

minimum PWM output pulse width:

This is equal to one High Resolution Clock Period (HRP). The HRP is defined by the 6-bit High Resolution Prescale Factor (hr) which is user defined, giving prescale factors of 1 to 64, with a linear increment of codes.

Therefore, the minimum PWM output pulse width = $HRP(\min) = hr(\min)/SYSCLK = 1/SYSCLK$

For example, for a SYSCLK of 30 MHz, the minimum PWM output pulse width = $1/30 = 33.33\text{ns}$

minimum input pulses we can capture:

The input pulse width must be greater or equal to the Low Resolution Clock Period (LRP), i.e., the HET loop (the HET program must fit within the LRP). The LRP is defined by the 3-bit Loop-Resolution Prescale Factor (lr), which is user defined, with a power of 2 increment of codes. That is, the value of lr can be 1, 2, 4, 8, 16, or 32.

Therefore, the minimum input pulse width = $LRP(\min) = hr(\min) * lr(\min)/SYSCLK = 1 * 1/SYSCLK$

For example, with a SYSCLK of 30 MHz, the minimum input pulse width = $1 * 1/30 = 33.33 \text{ ns}$

Note: Once the input pulse width is greater than LRP, the resolution of the measurement is still HRP. (That is, the captured value gives the number of HRP clocks inside the pulse.)

Abbreviations:

High resolution clock period = $HRP = hr/SYSCLK$

Loop resolution clock period = $LRP = hr*lr/SYSCLK$

hr = HET high resolution divide rate = 1, 2, 3,...63, 64

lr = HET low resolution divide rate = 1, 2, 4, 8, 16, 32

TMS470R1VF4B8

16/32-BIT RISC FLASH MICROCONTROLLER

SPNS094C – JUNE 2004 – REVISED AUGUST 2006

multi-buffered A-to-D converter (MibADC)

The multi-buffered A-to-D converter (MibADC) has a separate power bus for its analog circuitry that enhances the A-to-D performance by preventing digital switching noise on the logic circuitry which could be present on V_{SS} and V_{CC} from coupling into the A-to-D analog stage. All A-to-D specifications are given with respect to AD_{REFLO} unless otherwise noted.

Resolution 10 bits (1024 values)
 Monotonic Assured
 Output conversion code 00h to 3FFh [00 for $V_{AI} \leq AD_{REFLO}$; 3FF for $V_{AI} \geq AD_{REFHI}$]

MibADC recommended operating conditions[†]

		MIN	MAX	UNIT
AD_{REFHI}	A-to-D high -voltage reference source	V_{SSAD}	V_{CCAD}	V
AD_{REFLO}	A-to-D low-voltage reference source	V_{SSAD}	V_{CCAD}	V
V_{AI}	Analog input voltage	$V_{SSAD} - 0.3$	$V_{CCAD} + 0.3$	V
I_{AIC}	Analog input clamp current [‡] ($V_{AI} < V_{SSAD} - 0.3$ or $V_{AI} > V_{CCAD} + 0.3$)	- 2	2	mA

[†] For V_{CCAD} and V_{SSAD} recommended operating conditions, see the "device recommended operating conditions" table.

[‡] Input currents into any ADC input channel outside the specified limits could affect conversion results of other channels.

operating characteristics over full ranges of recommended operating conditions^{§¶}

PARAMETER	DESCRIPTION/CONDITIONS	MIN	TYP	MAX	UNIT		
R_i	Analog input resistance	See Figure 18		250	500	Ω	
C_i	Analog input capacitance	See Figure 18		Conversion		10	pF
				Sampling		30	pF
I_{AIL}	Analog input leakage current	See Figure 18		-1	1	μ A	
$I_{ADREFHI}$	AD_{REFHI} input current	$AD_{REFHI} = 3.6$ V, $AD_{REFLO} = V_{SSAD}$				5	mA
CR	Conversion range over which specified accuracy is maintained	$AD_{REFHI} - AD_{REFLO}$		3	3.6	V	
E_{DNL}	Differential nonlinearity error	Difference between the actual step width and the ideal value. (See Figure 19)				± 1.5	LSB
E_{INL}	Integral nonlinearity error	Maximum deviation from the best straight line through the MibADC. MibADC transfer characteristics, excluding the quantization error. (See Figure 20)				± 2	LSB
E_{TOT}	Total error/Absolute accuracy	Maximum value of the difference between an analog value and the ideal midstep value. (See Figure 21)				± 2	LSB

[§] $V_{CCAD} = AD_{REFHI}$

[¶] 1 LSB = $(AD_{REFHI} - AD_{REFLO})/2^{10}$ for the MibADC



multi-buffered A-to-D converter (MibADC) (continued)

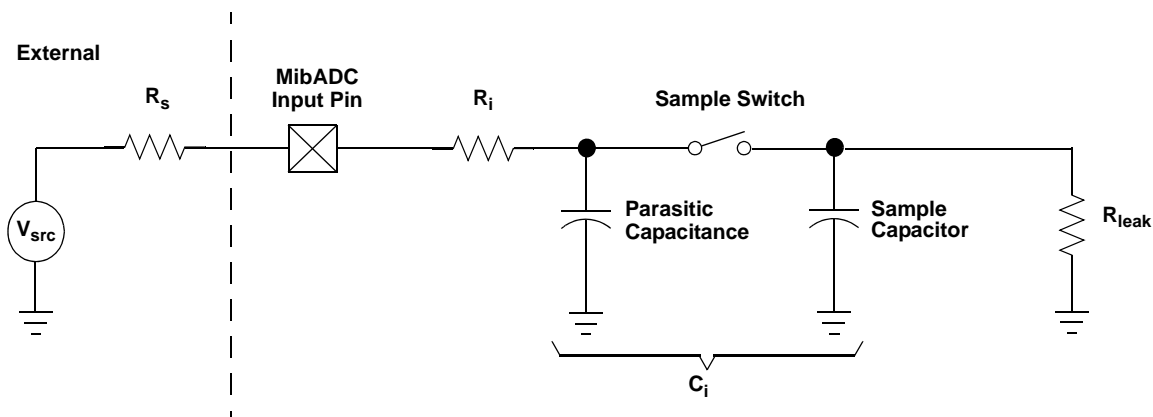

Figure 18. MibADC Input Equivalent Circuit

multi-buffer ADC timing requirements

		MIN	NOM	MAX	UNIT
$t_{c(ADCLK)}$	Cycle time, MibADC clock	0.05			μs
$t_{d(SH)}$	Delay time, sample and hold time	1			μs
$t_{d(C)}$	Delay time, conversion time	0.55			μs
$t_{d(SHC)}^\dagger$	Delay time, total sample/hold and conversion time	1.55			μs

† This is the minimum sample/hold and conversion time that can be achieved. These parameters are dependent on many factors; for more details, see the *TMS470R1x Multi-Buffered Analog-to-Digital Converter (MibADC) Reference Guide* (literature number SPNU206).

TMS470R1VF4B8

16/32-BIT RISC FLASH MICROCONTROLLER

SPNS094C – JUNE 2004 – REVISED AUGUST 2006

multi-buffered A-to-D converter (MibADC) (continued)

The differential nonlinearity error shown in Figure 19 (sometimes referred to as differential linearity) is the difference between an actual step width and the ideal value of 1 LSB.

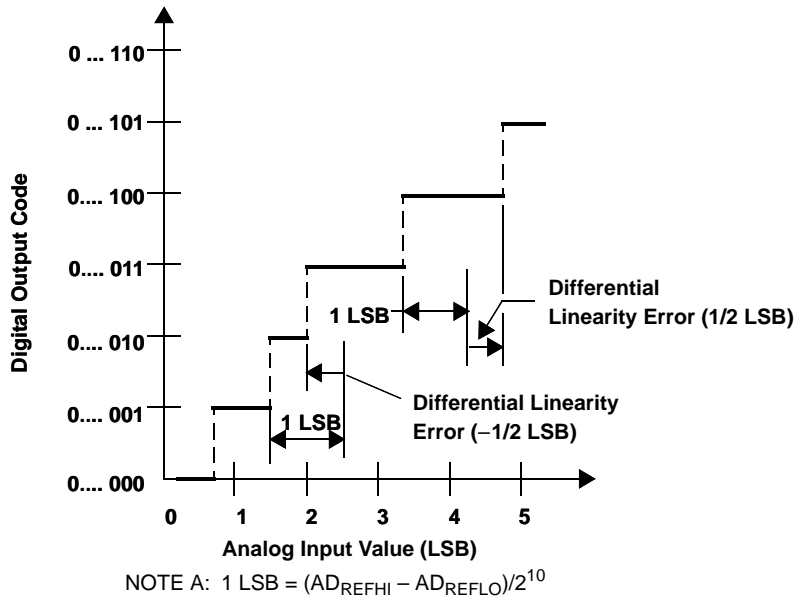

Figure 19. Differential Nonlinearity (DNL)

The integral nonlinearity error shown in Figure 20 (sometimes referred to as linearity error) is the deviation of the values on the actual transfer function from a straight line.

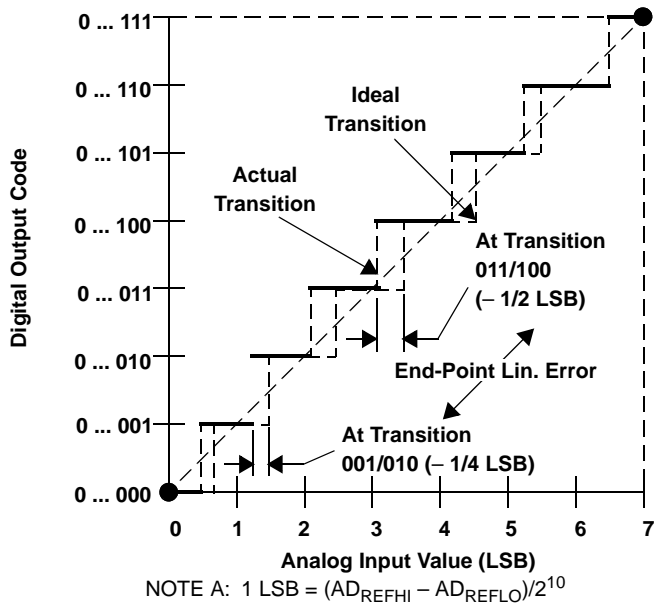

Figure 20. Integral Nonlinearity (INL) Error

multi-buffer A-to-D converter (MibADC) (continued)

The absolute accuracy or total error of an MibADC as shown in Figure 21 is the maximum value of the difference between an analog value and the ideal midstep value.

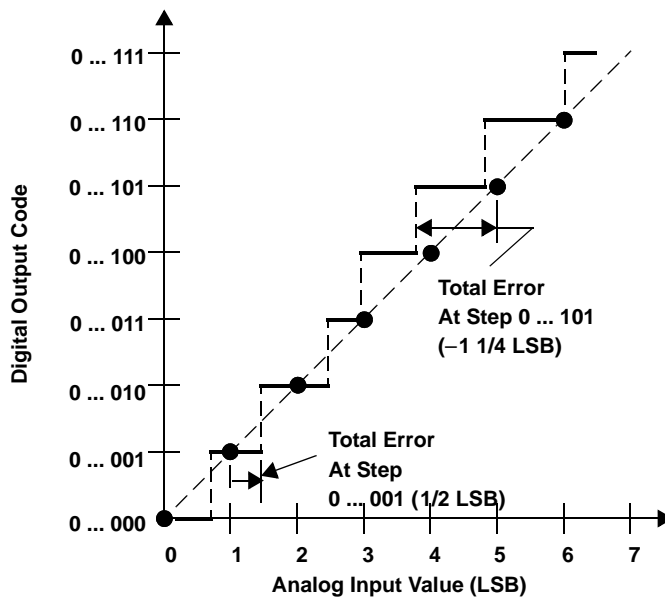

Figure 21. Absolute Accuracy (Total) Error

- NOTES: A. All linear dimensions are in millimeters.
B. This drawing is subject to change without notice.
C. Falls within JEDEC MS-026

Thermal Resistance Characteristics

PARAMETER	°C/W
R _{θJA}	43
R _{θJC}	5

TMS470R1VF4B8

16/32-BIT RISC FLASH MICROCONTROLLER

SPNS094C – JUNE 2004 – REVISED AUGUST 2006

MECHANICAL DATA

PZ (S-PQFP-G100)

PLASTIC QUAD FLATPACK

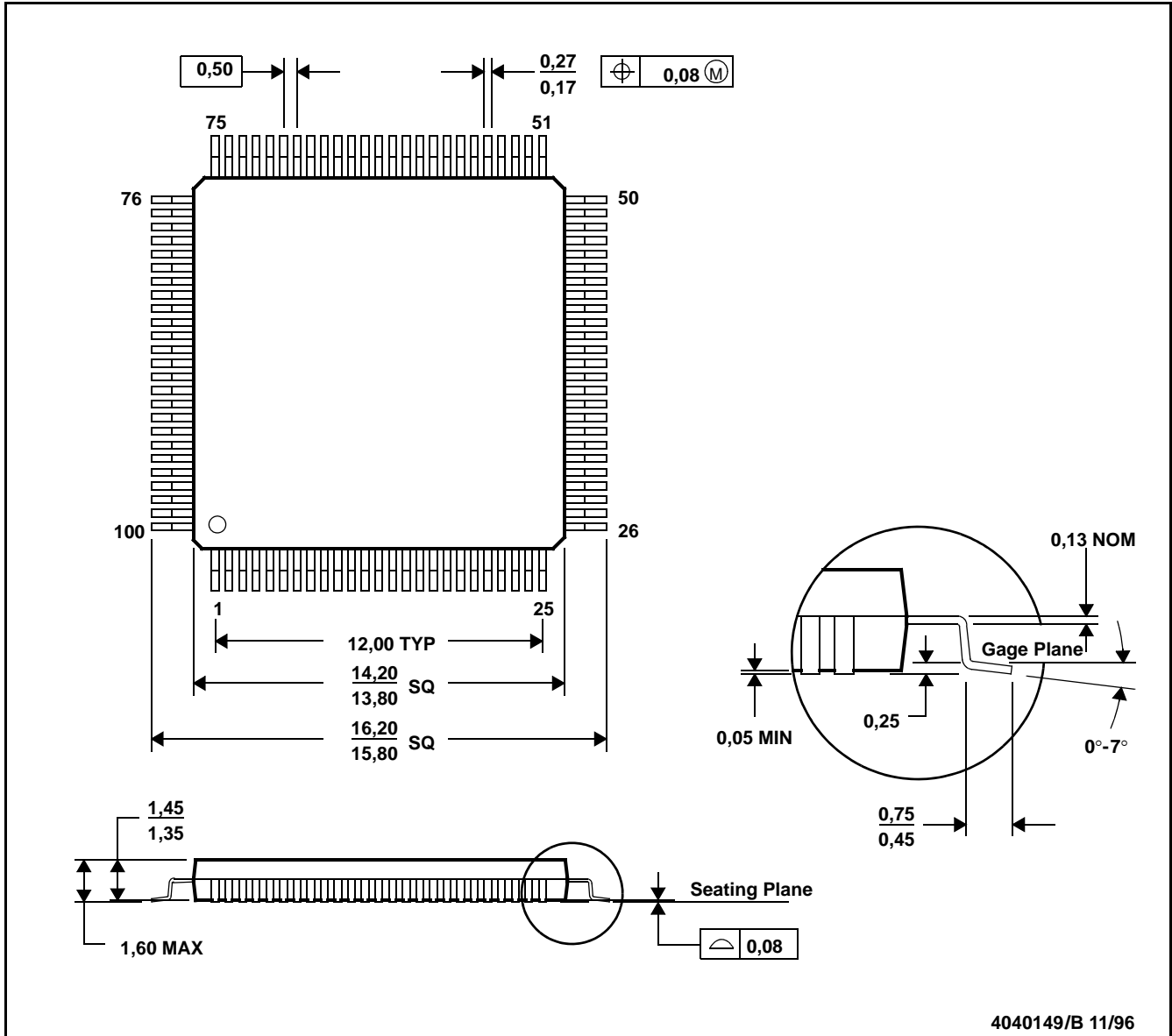

4040149/B 11/96

- NOTES:
- A. All linear dimensions are in millimeters.
 - B. This drawing is subject to change without notice.
 - C. Falls within JEDEC MS-026

Thermal Resistance Characteristics

PARAMETER	°C/W
$R_{\theta JA}$	48
$R_{\theta JC}$	5

List of Figures

[TMS470R1VF4B8 100-Pin PZ Package \(TOP VIEW\)](#)

[Functional Block Diagram](#)

[Figure 1. TMS470R1VF4B8 Memory Map](#)

[Figure 2. TMS470R1x Family Nomenclature](#)

[Figure 3. Test Load Circuit](#)

[Figure 4. Crystal/Clock Connection](#)

[Figure 5. CLKOUT Timing Diagram](#)

[Figure 6. ECLK Timing Diagram](#)

[Figure 7. PORRST Timing Diagram](#)

[Figure 8. CMOS-Level Outputs](#)

[Figure 9. CMOS-Level Inputs](#)

[Figure 10. SPIn Master Mode External Timing \(CLOCK PHASE = 0\)](#)

[Figure 11. SPIn Master Mode External Timing \(CLOCK PHASE = 1\)](#)

[Figure 12. SPIn Slave Mode External Timing \(CLOCK PHASE = 0\)](#)

[Figure 13. SPIn Slave Mode External Timing \(CLOCK PHASE = 1\)](#)

[Figure 14. MibSPI Master Mode External Timing \(CLOCK PHASE = 0\)](#)

[Figure 15. MibSPI Master Mode External Timing \(CLOCK PHASE = 1\)](#)

[Figure 16. SCIn Isosynchronous Mode Timing Diagram for Internal Clock](#)

[Figure 17. SCIn Isosynchronous Mode Timing Diagram for External Clock](#)

[Figure 18. MibADC Input Equivalent Circuit](#)

[Figure 19. Differential Nonlinearity \(DNL\)](#)

[Figure 20. Integral Nonlinearity \(INL\) Error](#)

[Figure 21. Absolute Accuracy \(Total\) Error](#)

[Mechanical Data](#)

TMS470R1VF4B8

16/32-BIT RISC FLASH MICROCONTROLLER

SPNS094C – JUNE 2004 – REVISED AUGUST 2006

List of Tables

- [Table 1. Device Characteristics](#)
- [Table 2. TMS470R1VF4B8 Memory Selection Assignment](#)
- [Table 3. VF4B8 Peripherals, System Module, and Flash Base Addresses](#)
- [Table 4. Interrupt Priority \(CIM\)](#)
- [Table 5. MibADC Event Hookup Configuration](#)
- [Table 6. MibSPI Event Hookup Configuration](#)
- [Table 7. TMS470 Device ID Bit Allocation Register](#)
- [Table 8. Device Part Number](#)

TMS470R1VF4B8
16/32-BIT RISC FLASH MICROCONTROLLER
REVISION HISTORY

REVISION HISTORY

REV	DATE	NOTES
C	8/06	Updates: Throughout, maximum core supply voltage changed from 2.05V to 2.06V Page 1, core supply voltage conditions under 56MHz and 85C ambient, 115C junction temperature added Page 5, core supply voltage conditions under 56MHz and 85C ambient, 115C junction temperature added Page 23, minimum supply voltage and input voltage ranges changed from -0.3V to -0.5V Page 23, operating junction temperature range broken out into A, T, and Q versions Page 23, core supply voltage conditions under 56MHz and 85C ambient, 115C junction temperature added Page 24, RST removed from I _{OH} listing Page 36, timing #5 updated

IMPORTANT NOTICE

Texas Instruments Incorporated and its subsidiaries (TI) reserve the right to make corrections, modifications, enhancements, improvements, and other changes to its products and services at any time and to discontinue any product or service without notice. Customers should obtain the latest relevant information before placing orders and should verify that such information is current and complete. All products are sold subject to TI's terms and conditions of sale supplied at the time of order acknowledgment.

TI warrants performance of its hardware products to the specifications applicable at the time of sale in accordance with TI's standard warranty. Testing and other quality control techniques are used to the extent TI deems necessary to support this warranty. Except where mandated by government requirements, testing of all parameters of each product is not necessarily performed.

TI assumes no liability for applications assistance or customer product design. Customers are responsible for their products and applications using TI components. To minimize the risks associated with customer products and applications, customers should provide adequate design and operating safeguards.

TI does not warrant or represent that any license, either express or implied, is granted under any TI patent right, copyright, mask work right, or other TI intellectual property right relating to any combination, machine, or process in which TI products or services are used. Information published by TI regarding third-party products or services does not constitute a license from TI to use such products or services or a warranty or endorsement thereof. Use of such information may require a license from a third party under the patents or other intellectual property of the third party, or a license from TI under the patents or other intellectual property of TI.

Reproduction of information in TI data books or data sheets is permissible only if reproduction is without alteration and is accompanied by all associated warranties, conditions, limitations, and notices. Reproduction of this information with alteration is an unfair and deceptive business practice. TI is not responsible or liable for such altered documentation.

Resale of TI products or services with statements different from or beyond the parameters stated by TI for that product or service voids all express and any implied warranties for the associated TI product or service and is an unfair and deceptive business practice. TI is not responsible or liable for any such statements.

Following are URLs where you can obtain information on other Texas Instruments products and application solutions:

Products

Amplifiers	amplifier.ti.com
Data Converters	dataconverter.ti.com
DSP	dsp.ti.com
Interface	interface.ti.com
Logic	logic.ti.com
Power Mgmt	power.ti.com
Microcontrollers	microcontroller.ti.com
Low Power Wireless	www.ti.com/lpw

Applications

Audio	www.ti.com/audio
Automotive	www.ti.com/automotive
Broadband	www.ti.com/broadband
Digital Control	www.ti.com/digitalcontrol
Military	www.ti.com/military
Optical Networking	www.ti.com/opticalnetwork
Security	www.ti.com/security
Telephony	www.ti.com/telephony
Video & Imaging	www.ti.com/video
Imaging Wireless	www.ti.com/wireless

Mailing Address: Texas Instruments
Post Office Box 655303 Dallas, Texas 75265